

ILVE COMMERCIAL MULTI-RESIDENTIAL & HOME BUILDER PRODUCT RANGE

ILO60DCBV 60CM ELECTRIC BUILT-IN OVEN

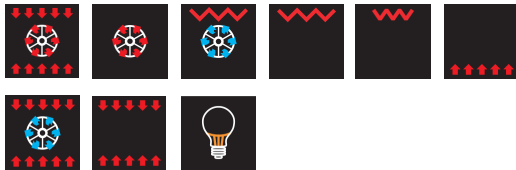

ILO60DCBV BUILT-IN ELECTRIC OVEN

FEATURES

- tangential fan cooling
- Time, 24h setting
- Touch control digital timer
- Accurate digital thermostat control: 0°C-250°C
- S-MOVE Soft close hinges
- Inner door with 'American' Style robust commercial design

FINISH

- Black glass
- Matte black handle & function knobs
- White etched cooking modes on control panel with symbols & words

SAFETY

- Cool touch triple glazed glass door

FUNCTIONS

- 9 functions — pizza, fan forced, fan grill, static grill, half static grill, bottom element, fan assisted, convection, light

CLEANING

- ULTRA-Clean smooth grey cavity
- easy-clean removable inner glass & door

CAPACITY & INTERIOR

- Oven cavity size (cm): 46w x 41.5d x 35.2h
- 5 cooking levels
- Dark / black tinted glass on door exterior

ACCESSORIES

- 1 x oven rack and 1 x grill/baking tray & grill insert

TECHNICAL INFORMATION

- 3.5kW/hr total electrical consumption
- 15 amp electrical connection, plug & lead supplied
- Size: 594W x 594H x 535D + 21mm fascia

Standard Option - Oven Colour



ILVE COMMERCIAL

MULTI-RESIDENTIAL & HOME BUILDER PRODUCT RANGE

ILO60DCBV 60CM ELECTRIC BUILT-IN OVEN

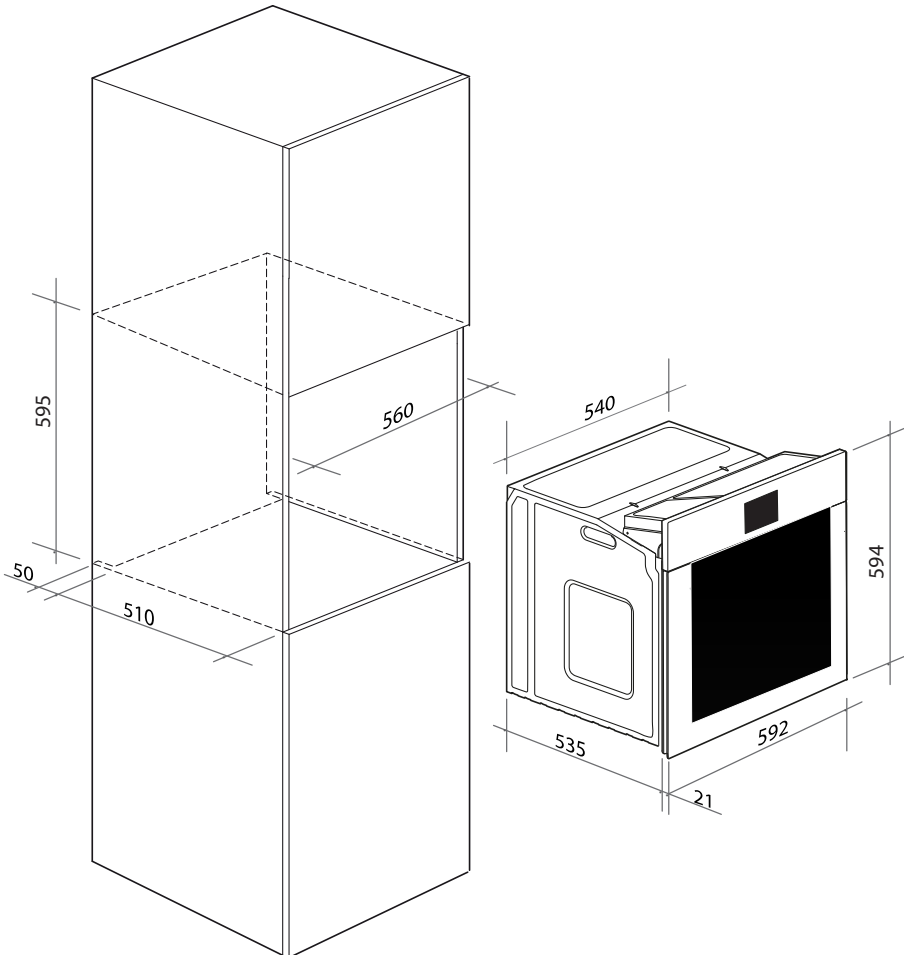

Oven

EAN code: 9341584039101 (ILO60DCBV)

Product Size: 592W x 594H x 535D + 21mm fascia

Total Electrical Load: 3.5kW/hr total electrical consumption

NB: drawings are not to scale — they are to be used as a guide only

FOLLOW US:



/ilve_appliances/



/ILVEappliances



/ILVE_appliances



/ILVEappliances

Page 2/2
05052020

Australia National Telephone Number 1300 MYILVE (694 583) New Zealand Telephone Number 0508 458 369
ILVE showrooms are open daily from 9am-5pm and Saturdays 10am-4pm

ilve.com.au

NSW & ACT (Head Office)

48-50 Moore Street
Leichhardt
F 02 8569 4699

VIC & SA

1211 Toorak Road
Camberwell
F 03 9809 2155

QLD

1/42 Cavendish Road
Coorparoo
F 07 3397 0850

WA & NT

Unit 10/55 Howe Street
Osborne Park
F 08 9201 9188

New Zealand

PO Box 11.160
Sockburn Christchurch
F 03 344 5906