

Title Bed 03 Assembly

MAST

The interlocking joinery of the Title Bed range has been designed with ease of assembly and longevity in mind. With the addition of high quality hardware, Title Beds can be assembled, disassembled and used without any affect on the structural integrity.

We recommend two people to assemble a bed. Assemble the bed on a soft surface ie. carpet, soft blanket etc. All hardware and tools are supplied.

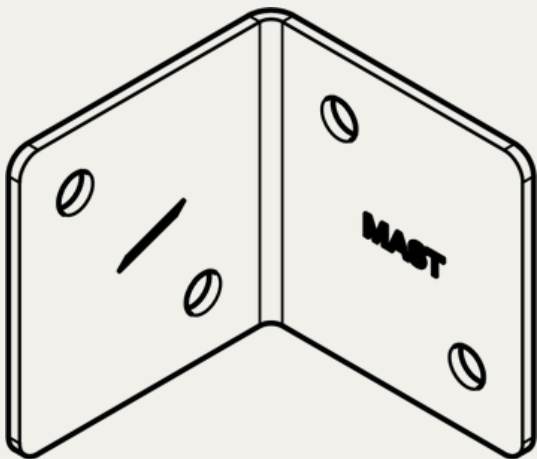

Corner Bracket x 4

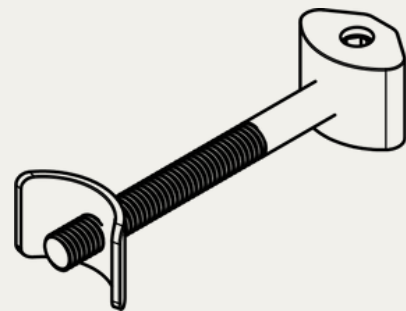

Cam Bolt x 4



Cam Hex Key



Bolt Hex Key



16mm Bolt x 32

Step 1:

Insert the support leg into the underside of the centre rail. Slot the centre rail in to the centre notch of each leg rail. No fixings required.

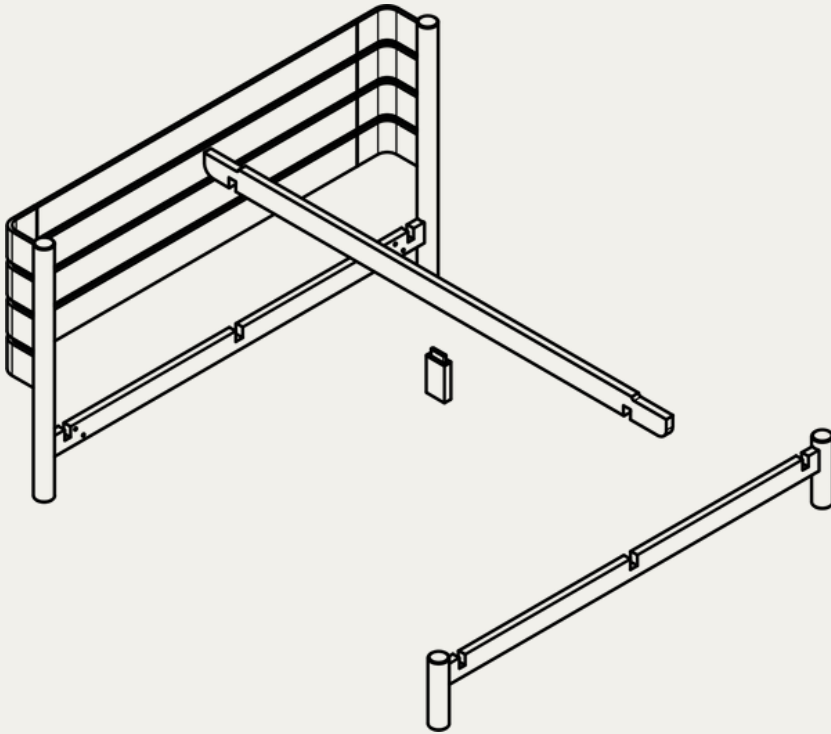

Step 2:

Slot the outside rails into the the leg rails. Ensure the threaded inserts are facing in.

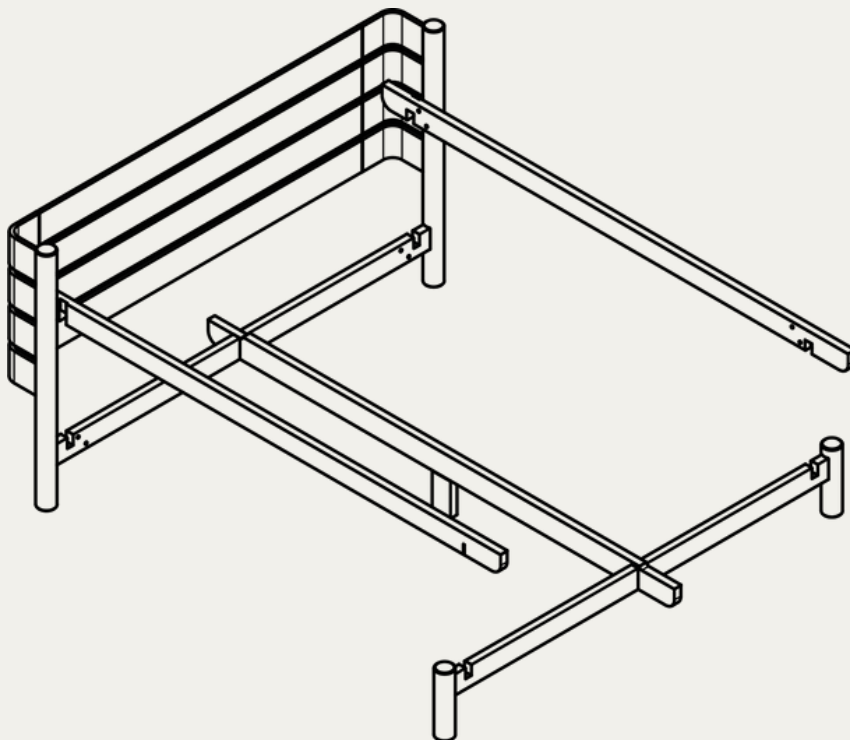

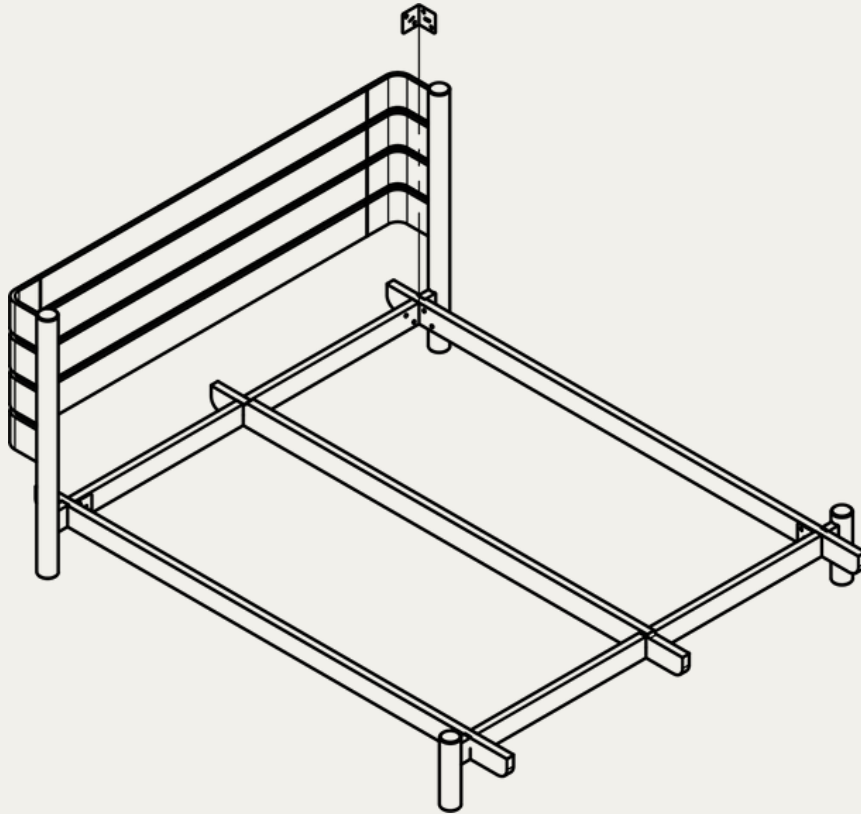

Step 3:

Attach the corner brackets using the 16mm bolts provided. These should be tightened to a 'snug' fit and not over tightened.

It is best to lift the bed frame into its final position at this point.

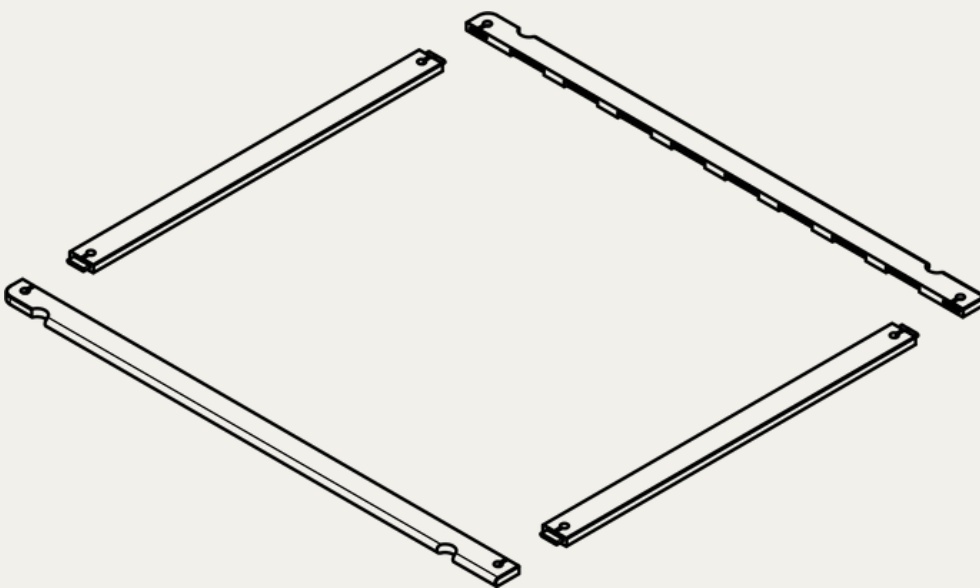

Step 4:

On a soft surface lay out the platform components with the mattress slat pockets facing down and hardware pockets facing up. Push the parts together.

Step 5:

Join the components using the Cam Bolts. These should be tightened to a 'snug' fit and not over tightened.

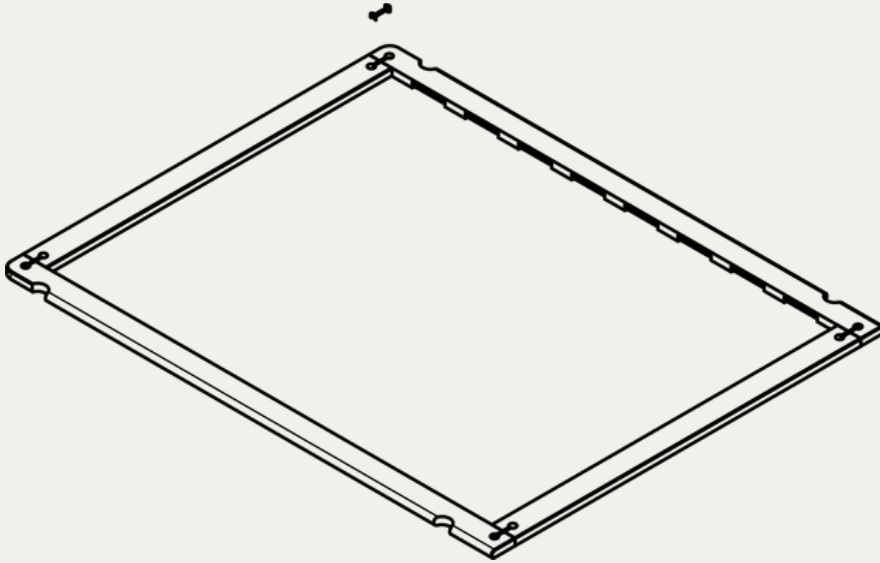

Step 6:

Flip the platform over and place it in the bed frame. This should be done by slowly lowering one side first, then carefully lowering the other side into place. No fixings are required.

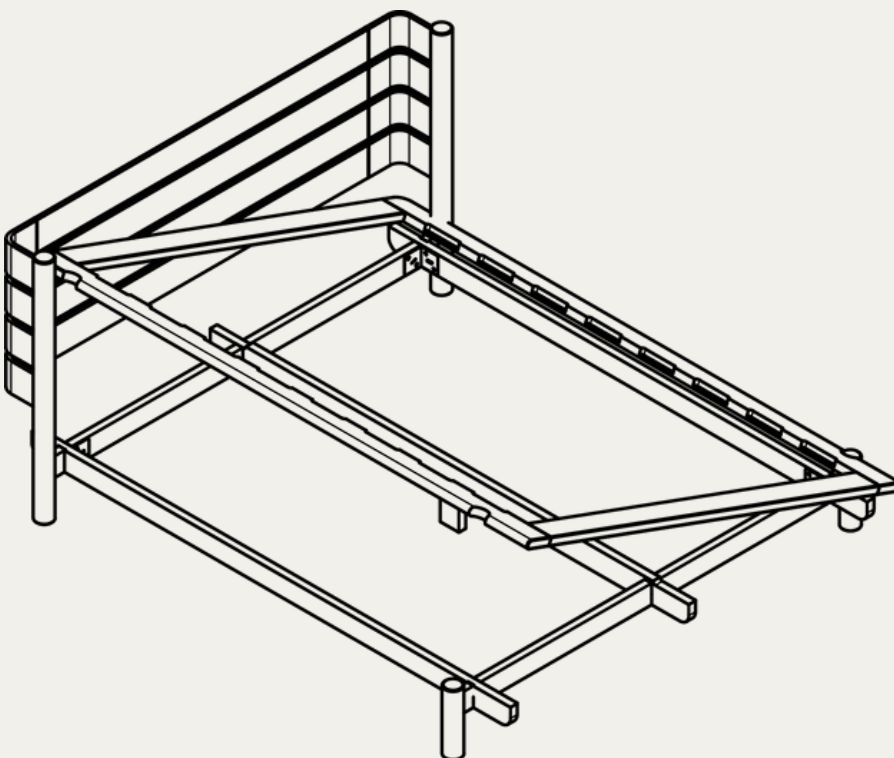

Step 7:

Place the mattress slats in the platform frame. No fixings are required.

