

# NewClassic Balances

## MS Semi-Micro Models

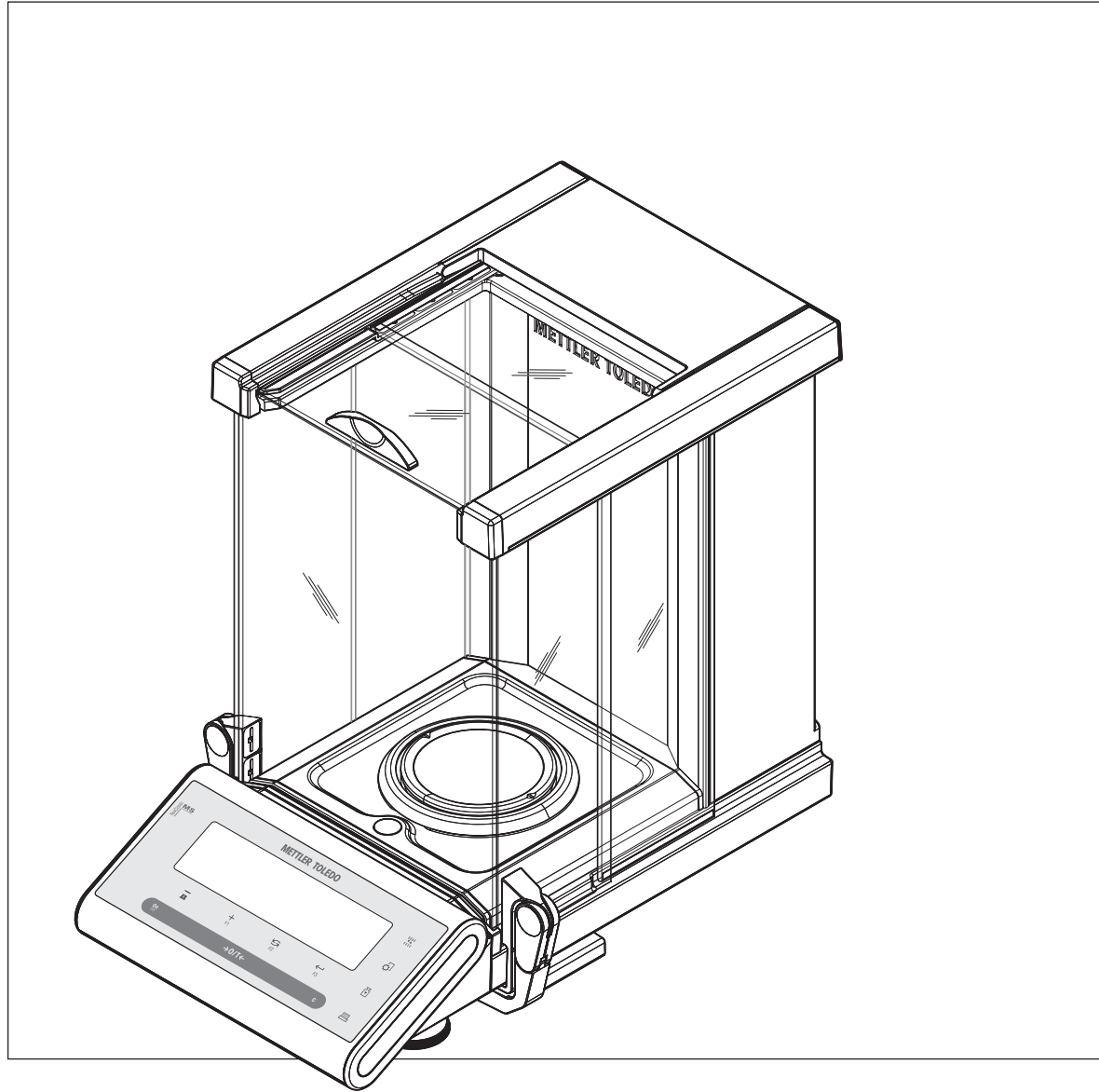

**METTLER TOLEDO**



# Table of Contents

<b>1</b>	<b>Introduction</b>	<b>7</b>
	1.1 Conventions and Symbols Used in These Operating Instructions	7
<b>2</b>	<b>Safety Precautions</b>	<b>8</b>
<b>3</b>	<b>Overview</b>	<b>9</b>
	3.1 Components	9
	3.2 Operation Keys	10
	3.3 Display Panel	11
<b>4</b>	<b>Setting up the Balance</b>	<b>13</b>
	4.1 Unpacking and Delivery Inspection	13
	4.2 Installing the Components	13
	4.3 Selecting the Location and Leveling the Balance	13
	4.3.1 Selecting the Location	13
	4.3.2 Leveling the Balance	14
	4.3.3 Power Supply	14
	4.3.4 Left/Right Operating of the Glass Draft Shield	15
	4.3.5 Weighing Below the Balance	15
	4.3.6 Transporting the Balance	16
	4.4 General Requirements	16
	4.4.1 Switching on the Balance	16
	4.4.2 Adjusting the Balance	16
	4.5 Adjustment (Calibration)	16
	4.5.1 Fully Automatic Adjustment FACT	16
	4.5.2 Manual Adjustment with Internal Weight	17
	4.5.3 Manual Adjustment with External Weight	17
	4.5.4 Customer Fine Adjustment	18
<b>5</b>	<b>Weighing Made Simple</b>	<b>20</b>
	5.1 Switching the Balance On and Off	20
	5.2 Performing a Simple Weighing	21
	5.3 Zero Setting / Taring	21
	5.4 METTLER TOLEDO DualRange Balances	21
	5.5 Switching Weight Units	22
	5.6 Recall / Recall Weight Value	22
	5.7 Weighing with the Weighing-in Aid	22
	5.8 Print / Transmit Data	22
<b>6</b>	<b>The Menu</b>	<b>23</b>
	6.1 What is in the Menu ?	23
	6.2 Menu Operation	24
	6.3 Description of Menu Topic	25
	6.3.1 Main Menu	25
	6.3.2 Basic Menu	26
	6.3.3 Advanced Menu	27
	6.3.4 Interface Menu	31

<b>7</b>	<b>Applications</b>		<b>39</b>
	7.1	Application "Piece Counting"	39
	7.2	Application "Percent Weighing"	42
	7.3	Application "Statistics"	44
	7.4	Application "Formulation" (Net Total Formulation)	46
	7.5	Application "Totaling"	49
	7.6	Application "Multiplication Factor Weighing"	51
	7.7	Application "Division Factor Weighing"	53
	7.8	Application "Density"	55
	7.8.1	Density Determination of Solids	55
	7.8.2	Density Determination of Liquids	57
	7.8.3	Formulae Used to Calculate Density	58
	7.9	Application "PipetteCheck"	61
	7.10	Application "Routine Test"	65
	7.11	Application "Diagnostics"	68
	7.11.1	Repeatability Test	68
	7.11.2	Display Test	69
	7.11.3	Key Test	70
	7.11.4	Motor Test	71
	7.11.5	Balance History	71
	7.11.6	Calibration History	72
	7.11.7	Balance Information	73
	7.11.8	Service Provider Information	74
<b>8</b>	<b>Communication with Peripheral Devices</b>		<b>75</b>
	8.1	Function PC-Direct	75
	8.2	USB Device Interface	76
<b>9</b>	<b>Firmware (Software) Updates</b>		<b>78</b>
	9.1	Operating Principle	78
	9.2	Update Procedure	78
<b>10</b>	<b>Error and Status Messages</b>		<b>80</b>
	10.1	Error Messages	80
	10.2	Status Messages	81
<b>11</b>	<b>Cleaning and Service</b>		<b>82</b>
	11.1	Cleaning the Glass Draft Shield	82
<b>12</b>	<b>Interface Specification</b>		<b>84</b>
	12.1	RS232C Interface	84
	12.2	USB Device Interface	84
	12.3	Aux Connection	85
	12.4	MT-SICS Interface Commands and Functions	85
<b>13</b>	<b>Technical Data</b>		<b>86</b>
	13.1	General Data	86
	13.2	Explanatory Notes for the METTLER TOLEDO AC Adapter	86

	13.3	Model-Specific Data	87
	13.4	Dimensions	89
<b>14</b>	<b>Accessories and Spare Parts</b>		<b>90</b>
	14.1	Accessories	90
	14.2	Spare Parts	94
	<b>Index</b>		<b>95</b>



# 1 Introduction

Thank you for choosing a METTLER TOLEDO balance.

The semi-micro balances of the NewClassic line combine a large number of weighing possibilities with easy operation.

These operating instructions

- apply to semi-micro balances MS models in the NewClassic line.
- are based on the initially installed firmware (software) version V 2.20.

## Please observe the following notes:

Some illustrations in these operating instructions are based on MS-S/MS-L models. They therefore might differ in some cases. However, functionality is not affected.

## 1.1 Conventions and Symbols Used in These Operating Instructions

Key designations are indicated by double angular brackets (e.g. «»).



This symbol indicates press key briefly (less than 1.5 s).



This symbol indicates press and hold key down (longer than 1.5 s).



This symbol indicates a flashing display.



This symbol indicates an automatic sequence.



These symbols indicate safety notes and hazard warnings which, if ignored, can cause personal danger to the user, damage to the balance or other equipment, or malfunctioning of the balance.

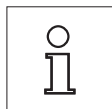

This symbol indicates additional information and notes. These make working with your balance easier, as well as ensuring that you use it correctly and economically.

## 2 Safety Precautions

Always operate and use your balance only in accordance with the instructions contained in this manual. The instructions for setting up your new balance must be strictly observed.

**If the balance is not used according to these Operating Instructions, protection of the balance may be impaired and METTLER TOLEDO assumes no liability.**



It is not permitted to use the balance in hazardous environments.



For use only in dry interior rooms.

Use only the original AC adapter delivered with your balance.

Do not use sharply pointed objects to operate the keyboard of your balance! Although your balance is very ruggedly constructed, it is nevertheless a precision instrument. Treat it with corresponding care.

Do not open the balance: It does not contain any parts which can be maintained, repaired, or replaced by the user. If you ever have problems with your balance, contact your METTLER TOLEDO dealer.

Use only balance accessories and peripheral devices from METTLER TOLEDO; they are optimally adapted to your balance.



Hazard of electric shock if the power cable is damaged! Check the power cable for damage regularly. Unplug the power cord immediately if the power cable is damaged.



### Disposal

In conformance with the European Directive 2002/96/EC on Waste Electrical and Electronic Equipment (WEEE) this device may not be disposed of in domestic waste. This also applies to countries outside the EU, per their specific requirements.

Please dispose of this product in accordance with local regulations at the collecting point specified for electrical and electronic equipment. If you have any questions, please contact the responsible authority or the distributor from which you purchased this device. Should this device be passed on to other parties (for private or professional use), the content of this regulation must also be related.

Thank you for your contribution to environmental protection.



### 3 Overview

#### 3.1 Components

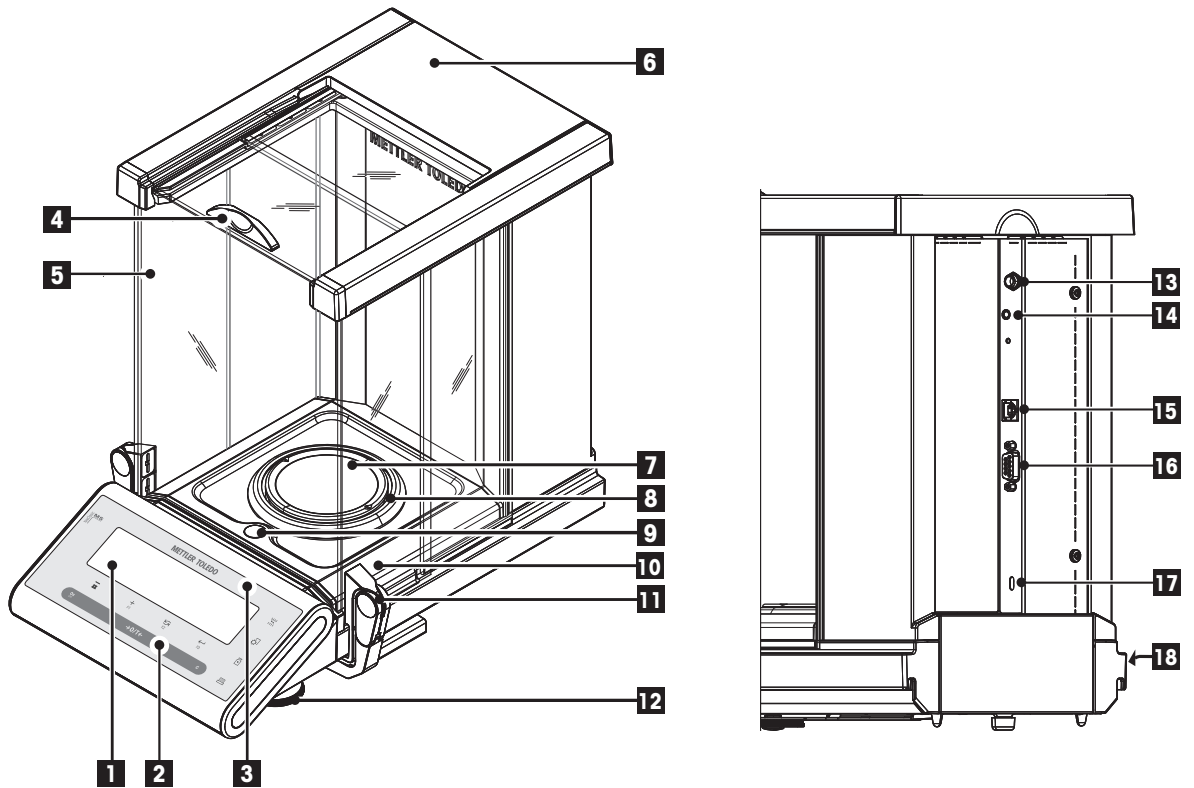





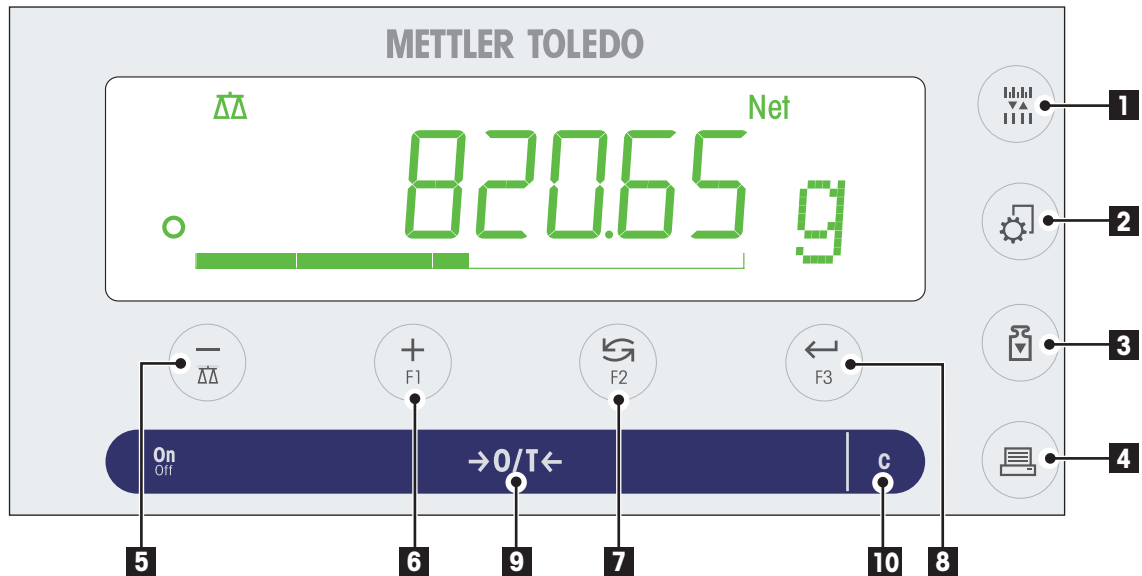





Name and Function of Components	
<b>1</b>	Display
<b>2</b>	Operation keys
<b>3</b>	Model sticker (with approved models only)
<b>4</b>	Handle for operation of the draft shield top door
<b>5</b>	Glass draftshield
<b>6</b>	Top cover
<b>7</b>	Weighing pan
<b>8</b>	Draft ring
<b>9</b>	Level indicator
<b>10</b>	Drip tray
<b>11</b>	Handle/Coupling element for the operation of the draft shield doors
<b>12</b>	Leveling feet
<b>13</b>	Socket for AC Adapter
<b>14</b>	Aux (connection for "ErgoSens" or foot-switch)
<b>15</b>	USB device interface
<b>16</b>	RS232C serial interface
<b>17</b>	Kensington slot for anti-theft purposes
<b>18</b>	Product label

## 3.2 Operation Keys











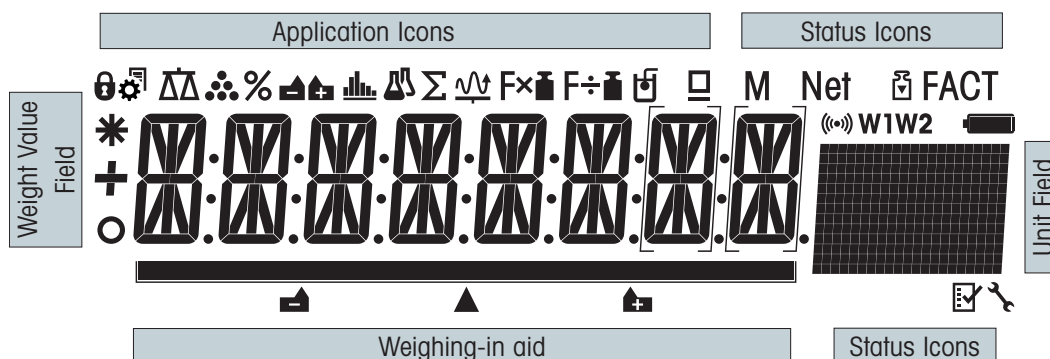



### Key Functions

No.	Key	Press briefly (less than 1.5 s) 	Press and hold (longer than 1.5 s) 
1		<ul style="list-style-type: none"> <li>To change display resolution (1/10d function) while application is running</li> <li><b>Note:</b> not available with approved models in selected countries.</li> </ul>	no function
2		<ul style="list-style-type: none"> <li>Enter or leave menu (Parameter settings)</li> <li>Save parameters</li> </ul>	no function
3		<ul style="list-style-type: none"> <li>Execute predefined adjusting (calibration) procedure</li> </ul>	no function
4		<ul style="list-style-type: none"> <li>Printout display value</li> <li>Printout active user menu settings</li> <li>Transfer data</li> </ul>	no function
5		<ul style="list-style-type: none"> <li>To navigate back (scroll up) within menu topics or menu selections</li> <li>Decrease (numerical) parameters within menu and in applications</li> </ul>	<ul style="list-style-type: none"> <li>To select the weighing application</li> <li>Decrease (numerical) parameters quickly within menu and in applications</li> </ul>
6		<ul style="list-style-type: none"> <li>To navigate forward (scroll down) within menu topics or menu selections</li> <li>Increase (numerical) parameters within menu and in applications</li> </ul>	<ul style="list-style-type: none"> <li>To select assigned F1 application and entering the parameter settings of application.</li> <li>Default F1 application assignment: Piece counting</li> <li>Increase (numerical) parameters quickly within menu and in applications</li> </ul>

No.	Key	Press briefly (less than 1.5 s)	Press and hold (longer than 1.5 s)
7	 F2	<ul style="list-style-type: none"> <li>With entries: scroll down</li> <li>To navigate through menu topics or menu selections</li> <li>To toggle between unit 1, recall value (if selected), unit 2 (if different from unit 1) and the application unit (if any)</li> </ul>	<ul style="list-style-type: none"> <li>To select assigned F2 application and entering the parameter settings of application.</li> <li>Default F2 application assignment: Percent weighing</li> </ul>
8	 F3	<ul style="list-style-type: none"> <li>To enter or leave menu selection (from / to menu topic)</li> <li>To enter application parameter or switch to next parameter</li> <li>To confirm parameter</li> </ul>	<ul style="list-style-type: none"> <li>To select assigned F3 application and entering the parameter settings of application.</li> <li>Default F3 application assignment: Statistics</li> </ul>
9	ON/OFF →0/T←	<ul style="list-style-type: none"> <li>Switch on</li> <li>Zero/Tare</li> </ul>	<ul style="list-style-type: none"> <li>Switch off</li> </ul>
10	C	<ul style="list-style-type: none"> <li>Cancel and to leave menu without saving (one step back in the menu).</li> </ul>	no function



### 3.3 Display Panel













Application Icons			
	Menu locked		Application "Formulation / Net-Total"
	Menu setting activated		Application "Totaling"
	Application "Weighing"		Application "Multiplication factor"
	Application "Piece counting"		Application "Division factor"
	Application "Percent weighing"		Application "Density"
	Application "Statistics"		Application "PipetteCheck"

#### Note

While an application is running, the corresponding application icon appears at the top of the display.

Status Icons			
<b>M</b>	Indicates stored value (Memory)		Applications "Diagnostics" and "Routine Test"
<b>Net</b>	Indicates Net weight values		Acoustic feedback for pressed keys activated
	Adjustments (calibration) started	<b>W1</b>	Weighing range 1 (Dual Range models only)
<b>FACT</b>	FACT activated	<b>W2</b>	Weighing range 2 (Dual Range models only)

Status Icons						
	Service reminder		Not used			
Weight Value Field and Weighing-in aid						
	Indicates negative values		Brackets to indicate uncertified digits (approved models only)			
	Indicates unstable values		Marking of nominal or target weight			
	Indicates calculated values		Not used			
			Not used			
Unit Field						
	<b>g</b>	gram	<b>ozt</b>	troy ounce	<b>tls</b>	Singapore taels
	<b>kg</b>	kilogram	<b>GN</b>	grain	<b>tlt</b>	Taiwan taels
	<b>mg</b>	milligram	<b>dwt</b>	pennyweight	<b>tola</b>	tola
	<b>ct</b>	carat	<b>mom</b>	momme	<b>baht</b>	baht
	<b>lb</b>	pound	<b>msg</b>	mesghal		
	<b>oz</b>	ounce	<b>tlh</b>	Hong Kong taels		

## 4 Setting up the Balance



The balance must be disconnected from the power supply when carrying out all setup and mounting work.

### 4.1 Unpacking and Delivery Inspection

- 1 Open the packaging and carefully remove all components.
- 2 Check the delivered items.

**The standard scope of delivery contains the following items:**

- Balance with Draftshield
- Weighing pan with pan support
- Draft ring
- Drip tray
- Protective cover
- AC adapter
- Country specific power cable
- Operating instructions printed or on CD-ROM depending on the country
- Quick Guide
- EC declaration of conformity

### 4.2 Installing the Components

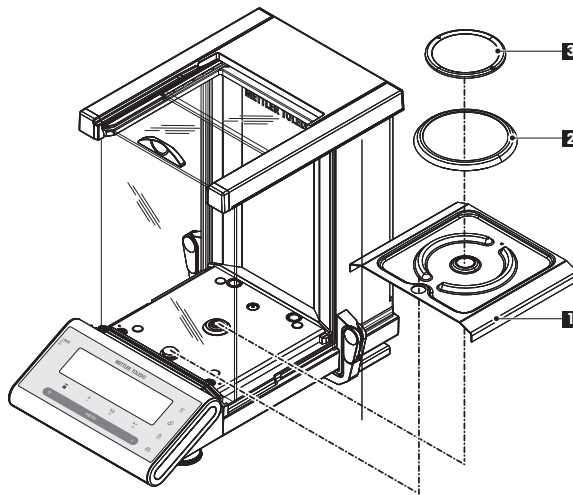

Push the side glass doors back as far as will go and place the following components on the balance in the specified order:

- 1 Place the drip tray (1) into the correct position.
- 2 Place the weighing pan (3).
- 3 Place the draft ring (2).

**Note:** Cleaning the draft shield see section "Maintenance and cleaning".

### 4.3 Selecting the Location and Leveling the Balance

Your balance is a precision instrument and will thank you for an optimum location with high accuracy and dependability.

#### 4.3.1 Selecting the Location

Select a stable, vibration-free position that is as horizontal as possible. The surface must be able to safely carry the weight of a fully loaded balance.

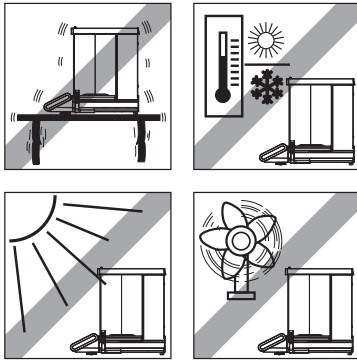

Observe ambient conditions (see Technical Data).

Avoid the following:

- Direct sunlight
- Powerful drafts (e.g. from fans or air conditioners)
- Excessive temperature fluctuations

### 4.3.2 Leveling the Balance

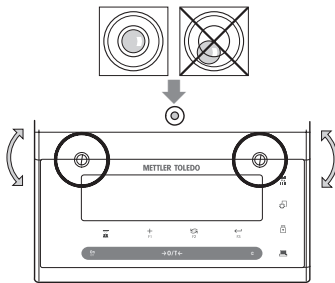

The balance has a level indicator and two adjustable leveling feet to compensate for slight irregularities in the surface of the weighing bench. The balance is exactly horizontal when the air bubble is in the middle of the level glass.

**Note:** The balance should be leveled and adjusted each time it is moved to a new location.

- Adjust the two leveling feet appropriately until the air bubble comes to rest exactly in the middle of the glass:

Air bubble at	"12 o'clock"	turn both feet clockwise
Air bubble at	"3 o'clock"	turn left foot clockwise, right foot counterclockwise
Air bubble at	"6 o'clock"	turn both feet counterclockwise
Air bubble at	"9 o'clock"	turn left foot counterclockwise, right foot clockwise

### 4.3.3 Power Supply

Your balance is supplied with an AC adapter with a country-specific power cable. The power supply is suitable for all line voltages in the range: 100 - 240 VAC, 50/60 Hz (for exact specifications, see section "technical data").



- First, check the local line voltage is in the range 100 - 240 VAC, 50/60 Hz and whether the power plug fits your local power supply connection. **If this is not the case, on no account connect the balance or the AC adapter to the power supply**, but contact the responsible METTLER TOLEDO dealer.
- **Only plug the adapter into a socket which is grounded.**



**Important:**

- Before operating, check all cables for damage.
- Guide the cables so that they cannot become damaged or interfere with the weighing process!
- Take care that the AC adapter cannot come into contact with liquids!
- The power plug must be always accessible.

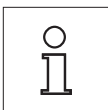

**Allow your balance to warm up for 60 minutes to enable it to adapt itself to the ambient conditions.**

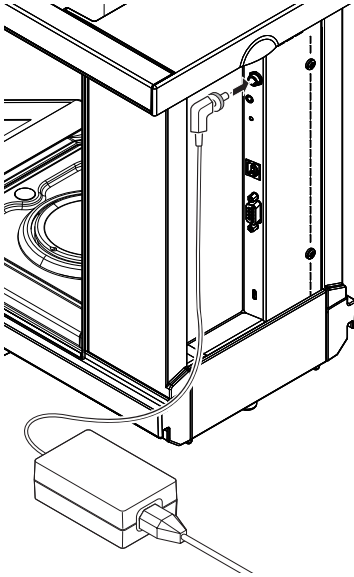

Connect the AC adapter to the connection socket on the back of the balance (see figure) and to the power line. Secure the connection to the balance by screwing the plug tight.

#### 4.3.4 Left/Right Operating of the Glass Draft Shield

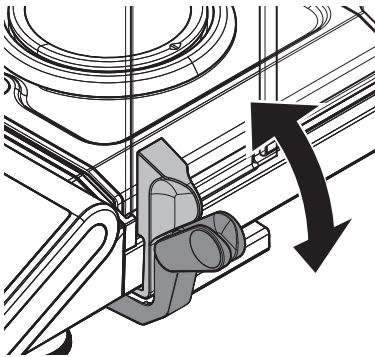

The glass draft shield of your balance can be adapted to the environmental conditions and your weighing style, as well as to the type of weighing and loading.

The position of the handles determines which door(s) of the draft shield (left, right, or both) is/are opened.

Try various different combinations by moving the external handles into the upper or lower position. We recommend you to set up the glass draft shield so that it only opens on the side where the balance is loaded. Your balance then works faster, because there are fewer troublesome currents of air than when both doors of the draft shield are opened together.

#### 4.3.5 Weighing Below the Balance

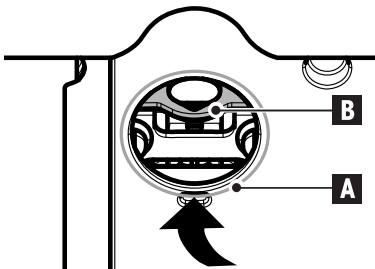

So that weighings can be carried out below the working surface (below-the-balance weighing), your balance is provided with a special hanger.

- 1 Switch off the balance and unplug the cable of the AC adapter from the back of the balance.
- 2 Remove any interface cable.
- 3 Push the side doors and the top door of the glass draft shield completely to the back. **Note:** Top cover must be closed.
- 4 Remove the weighing pan, the draft ring and the drip tray.
- 5 Carefully tip the balance over backwards, until it is lying on its back.
- 6 Remove the cap ( A ) and retain it. The hanger ( B ) for weighing below the balance is easily accessible now.
- 7 Carefully turn the balance to its normal position and reinstall all components in the reverse order.

## 4.3.6 Transporting the Balance

### Transporting over short distances

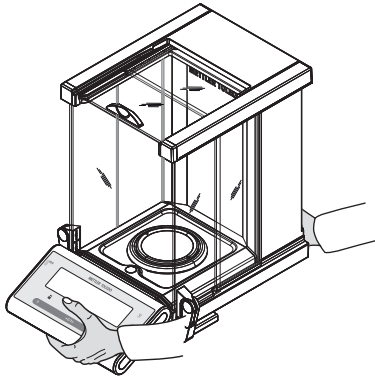

- 1 Switch off the balance and remove the power cable and any other cables from the balance.
- 2 Hold the balance with both hands as shown. Carefully lift the balance and carry it to its new location.
- 3 Refer to the notes in Section "Selecting the location" regarding the choice of an optimal location.



#### Caution:

Please do not lift the balance by the glass draft shield as not to damage it.

### Transporting over long distances

If you would like to transport or send your balance over long distances, **use the complete original packaging**.

## 4.4 General Requirements

### 4.4.1 Switching on the Balance

Before working with the balance, it must be warmed up in order to obtain accurate weighing results. To reach operating temperature, the balance must be connected to the power supply for at least 60 minutes.

#### See also

- Adjusting the Balance (page 16)

### 4.4.2 Adjusting the Balance

To obtain accurate weighing results, the balance must be adjusted to match the gravitational acceleration at its location and depending on the ambient conditions. After reaching the operation temperature, adjusting is necessary

- before the balance is used for the first time.
- when the balance was disconnected from the power or in case of power failure.
- after a change of the location.
- at regular intervals during weighing service.

#### See also

- Switching on the Balance (page 16)

## 4.5 Adjustment (Calibration)

### Attention

Before adjusting the balance, it must be warmed up.

### 4.5.1 Fully Automatic Adjustment FACT

**Note:** On models with FACT only.

The **factory setting** is fully automatic adjustment **FACT** (Fully Automatic Calibration Technology) with the internal weight (see also section "The Menu").

The balance adjusts itself automatically:



- after the warm-up phase on connection to the power supply.
- when a change in the ambient conditions, e.g. the temperature, could lead to a noticeable deviation in the measurement.
- on a predefined time. (see menu topic "FACT")
- time interval. (with OIML accuracy class II approved models)

#### 4.5.2 Manual Adjustment with Internal Weight

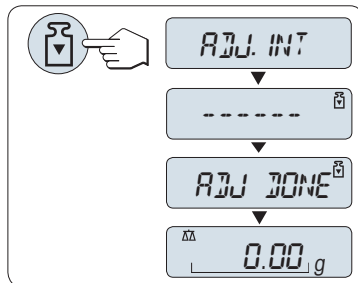

**Requirement:** To carry out this operation, in the menu topic "**CAL**" (Adjustment) of advanced menu "**ADJ.INT**" must be selected.

- 1 Unload weighing pan
- 2 Press «» to execute "Internal Adjustment".

The balance adjusts itself automatically. The adjusting is finished when the message "**ADJ DONE**" appears briefly on the display. The balance returns to the last active application and is ready for operation.

#### Sample adjustment printout using internal weight:

```

-- Internal Adjustment --
21.Jan 2009      12:56

METTLER TOLEDO

Balance Type     MS4002S
SNR              1234567890

Temperature      22.5 °C
Diff             3 ppm

Adjustment done
-----

```

#### 4.5.3 Manual Adjustment with External Weight

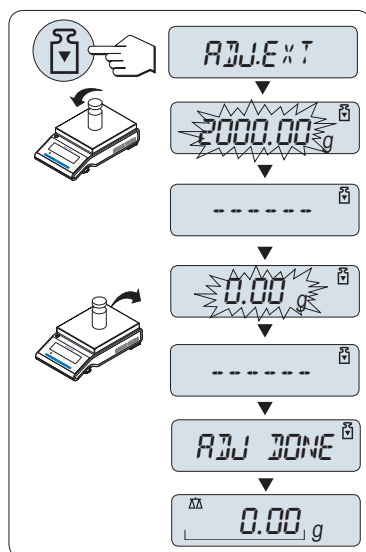

**Requirement:** To carry out this operation, in the menu topic "**CAL**" (Adjustment) of advanced menu "**ADJ.EXT**" must be selected.

#### Note

We recommend to disable FACT.

- 1 Have required adjustment weight ready.
- 2 Unload weighing pan.
- 3 Press «» briefly to execute "External Adjustment". The required (predefined) adjustment weight value flashes on the display.
- 4 Place adjustment weight in center of pan. The balance adjusts itself automatically.
- 5 When "0.00 g" flashes, remove adjustment weight.

The adjusting is finished when the message "**ADJ DONE**" appears briefly on the display. The balance returns to the last active application and is ready for operation.

### Sample adjustment printout using external weight:

```
- External Adjustment --
21.Jan 2009      12:56

METTLER TOLEDO

Balance Type      MS4002S
SNR               1234567890

Temperature       22.5 °C
Nominal           2000.00 g
Actual            1999.99 g
Diff              5 ppm

Adjustment done

Signature

.....
-----
```

## 4.5.4 Customer Fine Adjustment

### Attention

This function should be executed only by trained personnel.

The function customer fine adjustment "**ADJ.CUST.F**" allows you to adjust the value of the internal adjustment weight with your own adjustment weight. The adjustable range of the adjustment weight is possible only in a very small range. Customer fine adjustment impacts the function of internal adjustment. The customer fine adjustment can be deactivated at any time.

### Note

- This feature is available on models with internal weight only.
- Because of certification legislation, approved models cannot be adjusted with customer fine adjustment (depending on selected countries' certification legislation).
- Use certificated weights.
- Balance and test weight have to be on operating temperature.
- Observe the correct environmental conditions.

## Execute customer fine adjustment

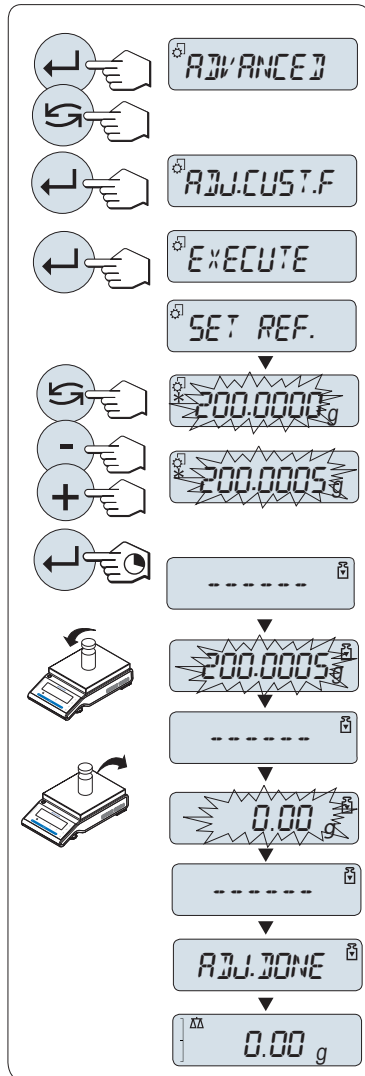

- The balance is under measuring condition.
- 1 Have required adjustment weight ready.
  - 2 Unload weighing pan
  - 3 Select in the menu "**ADVANCED**": **ADJ.CUST.F**
  - 4 Confirm "**ADJ.CUST.F**" with «←».
  - 5 To carry out this operation select "**EXECUTE**"
  - 6 Start Adjustment with «←»
    - ⇒ "**SET REF.**" appears briefly.
    - ⇒ The last saved value flashes on the display.
  - 7 Select the target adjustment weight.
    - For coarse setting, press «↻» to change the value.
    - For fine setting, press «+» to increase the value or press "-" to decrease the value.
  - 8 Press and hold «←» to confirm and execute "**ADJ.CUST.F**".
    - ⇒ The required adjustment weight value flashes in the display. This could take some time.
  - 9 Place required adjustment weight in center of pan.
  - 10 Remove adjustment weight when zero is flashing.
  - 11 Wait until "**ADJ DONE**" briefly appears.
    - ⇒ The adjusting is finished when the message "**ADJ DONE**" appears briefly on the display. The balance returns to the last active application and is ready for operation
    - ⇒ If the error message "**WRONG ADJUSTMENT WEIGHT**" appears, the weight is not within the allowed value range and could not be accepted. "**ADJ.CUST.F**" could not be executed.

### Note

Storing the adjustment is not required.

## Deactivate customer fine adjustment

- 1 Select in the menu "**ADVANCE**": "**ADJ.CUST.F**".
  - 2 Confirm "**ADJ.CUST.F**" with «←».
  - 3 To carry out this operation select "**RESET**"
  - 4 Start **RESET** by pressing «←»
    - ⇒ "**NO?**" appears.
  - 5 Select "**YES?**" and confirm with «←».
- ⇒ The adjusting is finished when the message "**ADJ DONE**" appears briefly on the display. The balance returns to the last active application and is ready for operation with initial adjustment.

## 5 Weighing Made Simple



This section shows you how to perform simple weighings and how you can accelerate the weighing process.

### 5.1 Switching the Balance On and Off

#### Switching on

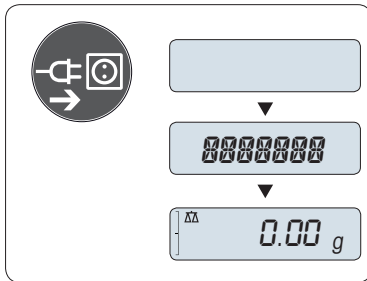

#### Connecting to the mains

- 1 Remove any load from weighing pan.
- 2 Connect balance via AC adapter to the mains.

The balance performs a display test (all segments in the display light up briefly), "**WELCOME**", Software version, **Maximum load** and **Readability** appears briefly. (Startup "**FULL**" mode only)

After the warm-up time, the balance is ready for weighing or for operation with the last active application, **see** General Requirements.

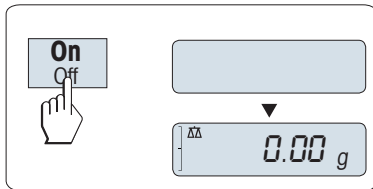

#### Standby mode

- Press «**On**».

The balance is ready for weighing or for operation with the last active application. Approved balances will execute an initial zero.

#### Switching off

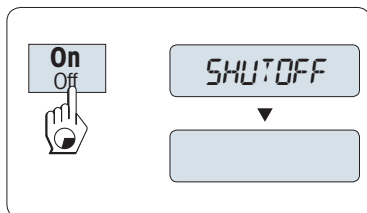

- Press and hold the «**Off**» key until "**SHUTOFF**" appears on the display. Release the key.

⇒ Balance switches into standby mode.

#### Note:

- After switching on from standby mode, your balance needs no warm-up time and is immediately ready for weighing.
- Standby mode is not possible with approved balances (only available in selected countries).
- If your balance has been switched off after a preselected time, the display is dimly lit and shows date, time, maximum load and readability.
- If your balance has been switched off manually, the display is off.
- To completely switch off mains operated balances, they must be disconnected from the power supply.

## 5.2 Performing a Simple Weighing

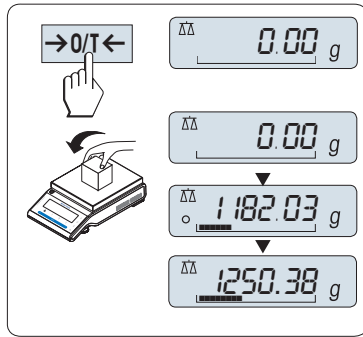

- 1 Press «→0/T←» to zero the balance.  
**Note:** If your balance is not in the weighing mode, press and hold the « $\Delta\Delta$ » key down until "WEIGHING" appears in the display. Release the key. Your balance is in the weighing mode and set to zero.
- 2 Place weighing sample on the weighing pan.
- 3 Wait until the instability detector "O" disappears and the stability beep sounds.
- 4 Read the result.

## 5.3 Zero Setting / Taring

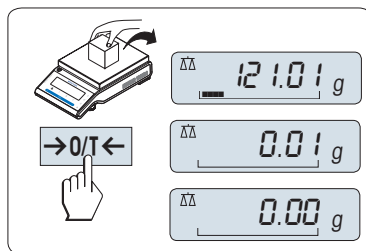

### Zero setting

- 1 Unload the balance.
- 2 Press «→0/T←» to set the balance to zero. All weight values are measured in relation to this zero point (see menu topic "ZERO RNG").

**Note:** Use the «→0/T←» zeroing key before you start with a weighing.

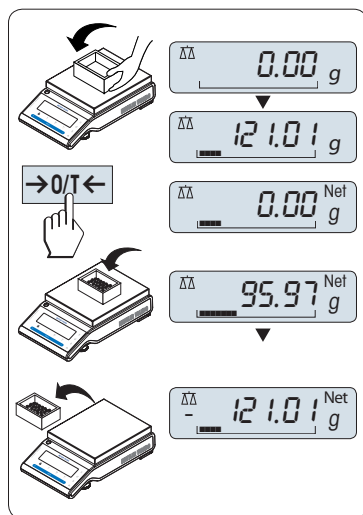

### Taring

If you are working with a weighing container, first set the balance to zero.

- 1 Place empty container on the balance. The weight is displayed.
- 2 Press «→0/T←» to tare the balance.

"0.00 g" and "Net" appears in the display. "Net" indicates that all weight values displayed are net values.

### Note:

- If the container is removed from the balance, the tare weight will be shown as a negative value.
- The tare weight remains stored until the «→0/T←» key is pressed again or the balance is switched off.
- With METTLER TOLEDO DeltaRange balances, the fine range with its 10 times smaller display increments (depending on the model) is available again after every taring operation.

## 5.4 METTLER TOLEDO DualRange Balances

METTLER TOLEDO DualRange balances have two ranges. These models have a fix fine (semi-micro) range between 0 g and "**Maximum load, fine range**". In this fine range the balance shows the result with a higher resolution, i.e. with one decimal place more.

## 5.5 Switching Weight Units

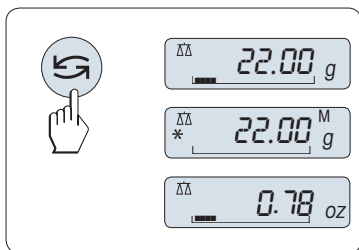

The «↔» key can be used at any time to toggle between weight unit "UNIT 1", "RECALL" value (if selected) and weight unit "UNIT 2" (if different from weight unit 1) and the application unit (if any).

## 5.6 Recall / Recall Weight Value

Recall stores stable weights with an absolute display value bigger than 10d.

**Requirement:** The function "RECALL" must be activated in the menu.

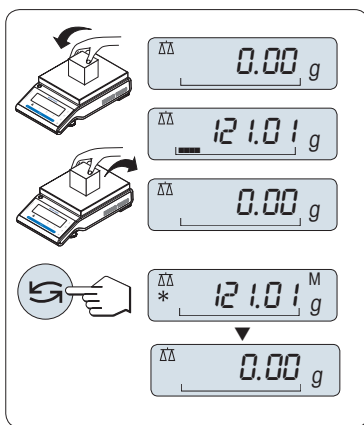

- 1 Load weighing sample. The display shows weight value and stores stable value.
- 2 Remove weighing sample. When the weight is removed the Display shows zero.
- 3 Press «↔». The display shows last stored stable weight value for 5 seconds together with asterisk (\*) and Memory (M) symbols. After 5 seconds the display goes back to zero. This can be repeated unlimited times.

### Delete last weight value

As soon a new stable weight value is displayed, the old recall value becomes replaced by the new weight value. When pressing «→0/T←», the recall value is set to 0.

**Note:** If the power is switched off, the recall value is lost. The recall value can not be printed.

## 5.7 Weighing with the Weighing-in Aid



The weighing-in aid is a dynamic graphic indicator which shows the used amount of the total weighing range. You can thus recognize at a glance when the load on the balance approaches the maximum load.

## 5.8 Print / Transmit Data

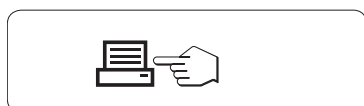

Pressing the «🖨️» key transmits the weighing results over the interface e.g. to a printer or a PC.

## 6 The Menu

### 6.1 What is in the Menu ?



The Menu allows you to match your balance to your specific weighing needs. In the menu you can change the settings of your balance and activate functions. The main menu has 4 different menus and these contains 47 different **topics**, each of which allows you various **selection** possibilities. For Menu "**PROTECT**" see chapter "Description of menu topics" section "Main menu".

**Note:** See Quick Guide for the graphical overview of the menu (Menu Map) with all setting possibilities.

#### Menu "BASIC"

Topic	Description
<b>DATE</b>	Setting the current date.
<b>TIME</b>	Setting the current time.
<b>UNIT 1</b>	Specification of the 1 <sup>st</sup> weight unit in which the balance should show the result.
<b>UNIT 2</b>	Specification of the 2 <sup>nd</sup> weight unit in which the balance should show the result.
<b>KEY BEEP</b>	Setting the key beep level.
<b>STAB.BEEP</b>	Setting the stability beep level.
<b>RESET</b>	Call up of the factory settings.

#### Menu "ADVANCED"

Topic	Description
<b>WEIG.MODE</b>	Adapting the balance to the weighing mode.
<b>ENVIRON.</b>	Matching the balance to the ambient conditions.
<b>CAL</b>	Settings for the type of adjustment (calibration).
<b>ADJ.CUST.F</b>	Executing customer fine adjustment.
<b>FACT</b>	Settings for fully automatic balance adjustment based on a selected time.
<b>FACT PRT.</b>	Switching the automatic FACT printout on or off.
<b>DATE.FORM</b>	Setting the date format.
<b>TIME.FORM</b>	Preselection of the time format.
<b>RECALL</b>	Switching the application "Recall" for storing stable weights on or off.
<b>SHUTOFF</b>	Setting the time after which the balance should be switched off automatically.
<b>BCKLIGHT</b>	Setting the time after which the display backlight should be switched off automatically.
<b>DISPLAY</b>	Adjusting the brightness and contrast of the display.
<b>AUTOZERO</b>	Switching the automatic zero correction (Autozero) on or off.
<b>ZERO RNG</b>	Setting the zero limit of the zero/tare key.
<b>LANGUAGE</b>	Setting the preferred language.
<b>ASSIGN:F1</b>	Selection of assigned F1 key application and entering their parameter settings.
<b>ASSIGN:F2</b>	Selection of assigned F2 key application and entering their parameter settings.
<b>ASSIGN:F3</b>	Selection of assigned F3 key application and entering their parameter settings.
<b>DIAGNOSE</b>	Starting a diagnostic application.
<b>SERV.ICON</b>	Switching the service icon (service reminder) on or off.
<b>SRV.D.RST</b>	Reset service date and hours (service reminder).

#### Menu "INT.FACE"

Topic	Description
<b>RS232</b>	Matching the serial interface RS232C to a peripheral unit.
<b>HEADER</b>	Setting the header for printout of individual values.
<b>SINGLE</b>	Setting the information for printout of individual values.
<b>SIGN.L</b>	Setting the footer for printout of individual values.



Topic	Description
<b>LINE.FEED</b>	Setting line feed for printout of individual values.
<b>ZERO PRT.</b>	Setting the auto print function for printing zero.
<b>COM.SET</b>	Setting the data communication format of the serial interface RS232C.
<b>BAUDRATE</b>	Setting the transfer speed of the serial interface RS232C.
<b>BIT/PAR.</b>	Setting the character format (Bit/Parity) of the serial interface RS232C.
<b>STOPBIT</b>	Setting the character format (stop bit) of the serial interface RS232C.
<b>HD.SHAKE</b>	Setting the transfer protocol (Handshake) of the serial interface RS232C.
<b>RS.TX.E.O.L.</b>	Setting the end of line format of the serial interface RS232C (outgoing data).
<b>RS CHAR</b>	Setting the char set of the serial interface RS232C.
<b>USB</b>	Matching the USB interface to a peripheral unit.
<b>USB COM.S.</b>	Setting the data communication format of the USB interface.
<b>USB E.O.L.</b>	Setting the end of line format of the USB interface.
<b>USB CHAR</b>	Setting the char set of the USB interface.
<b>INTERVAL</b>	Selection of the time interval for the simulated print key press.
<b>ERGOSENS</b>	Settings for external key e.g. METTLER TOLEDO "ErgoSens"

## 6.2 Menu Operation

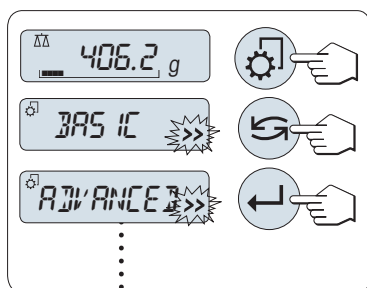
In this section you will learn how to work with the menu.





### Select Menu

- 1 Press «» to activate main menu. The first menu "**BASIC**" is displayed (except menu protection is active).
- 2 Press «» repeatedly to change menu (Scrolling down/up «+» / «-» keys).
- 3 Press «» to confirm the selection.

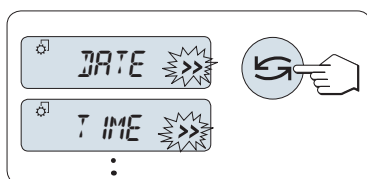
**Note:** The menu selection "**BASIC**", "**ADVANCED**" or "**INT.FACE**" can not be saved. The selection "**PROTECT**" must be saved.



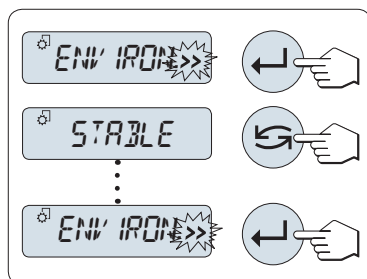

### Select Menu Topic

- Press «». The next menu topic appears in the display. Each time the «» or the «+» key is pressed, the balance switches to the next menu topic; the «-» key to the previous menu topic.



### Change Settings in a Selected Menu Topic

The ">>" flashing symbol in the display indicates selectable options available.

- 1 Press «». The display shows the current setting in the selected menu topic. Each time «» or «+» is pressed, the balance switches to the next selection; press «-» to the previous selection. After the last selection, the first is shown again.
- 2 Press «» to confirm the setting. For store the setting see section **Saving Settings and Closing the Menu**.

### Change Settings in a Submenu Selection

The same procedure as for menu topics.



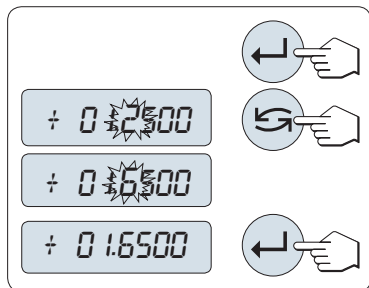

### Input Principle of Numerical Values

- 1 Press «←» for input of numerical values.
- 2 Press «→» to select a digit or a value (depending on the application). The selected digit or the selected value is blinking.
- 3 For changing digits or values, press «+» to scroll up or «-» to scroll down.
- 4 Press «←» to confirm the input.

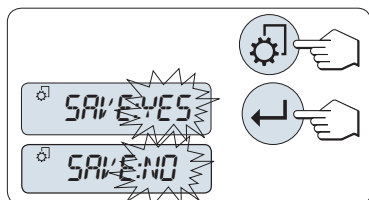

### Saving Settings and Closing the Menu

- 1 Press «⚙» briefly to leave menu topic.
- 2 Press «←» to execute "SAVE:YES". Changes are saved.
- 3 Press «←» to execute "SAVE:NO". Changes are not saved. To toggle between "SAVE:YES" and "SAVE:NO" press «↔».



### Cancel

- For leaving menu topic or menu selection without saving press «C» (one step back in the menu).

**Note:** If no entry is made within 30 seconds, the balance reverts to last active application mode. Changes are not saved. If changes are made, the balance asks "SAVE:NO".

## 6.3 Description of Menu Topic

In this section you will find information regarding the individual menu topics and the available selections.

### 6.3.1 Main Menu

Selecting the menu.

"BASIC"	The small "BASIC" menu for simple weighing is displayed.
"ADVANCED"	The extended "ADVANCED" menu for further weighing settings is displayed.
"INT.FACE"	The menu "INT.FACE" for all interface parameter settings for peripheral devices e.g. printer is displayed.
"PROTECT"	Menu protection. Protection of balance configurations against unmeant manipulation.
"OFF"	Menu protection is off. ( <b>Factory setting</b> )
"ON"	Menu protection is on. The menu <b>BASIC</b> , <b>ADVANCED</b> and <b>INT.FACE</b> are not displayed. This is indicated with "🔒" in the display.

#### Note:

- The menu selection "BASIC", "ADVANCED" or "INT.FACE" can not be saved.
- To activate "PROTECT" "ON" or "OFF", this selection must be saved.

## 6.3.2 Basic Menu

### "DATE" – Date

Setting the current date according to date format.

**Note:** A reset of the balance will not change this setting.

### "TIME" – Time

Setting the current time according to time format

<b>" +1H "</b>	Set the current time forwards by 1 hour (to adjust summer or winter time). <b>(Factory setting)</b>
<b>" -1H "</b>	Set the current time backwards by 1 hour (to adjust summer or winter time).
<b>"SET TIME"</b>	Enter the current time.

**Note:** A reset of the balance will not change this setting.

### "UNIT 1" – Weight Unit 1

Depending on requirements, the balance can operate with the following units (depending on the model)

- Only those weight units allowed by the appropriate national legislation are selectable.
- With approved balances, this menu topic has a fixed setting and cannot be changed.
- Conversion table for weight units see chapter Appendix.

#### Units:

<b>g</b> <sup>1)</sup>	Gram	<b>dwt</b>	Pennyweight
<b>kg</b> <sup>2)</sup>	Kilogram	<b>mom</b>	Momme
<b>mg</b> <sup>3)</sup>	Milligram	<b>msg</b>	Mesghal
<b>ct</b>	Carat	<b>tlh</b>	Tael Hong Kong
<b>lb</b>	Pound	<b>tls</b> <sup>4)</sup>	Tael Singapore
<b>oz</b>	Ounce (avdp)	<b>tlt</b>	Tael Taiwan
<b>ozt</b>	Ounce (troy)	<b>tola</b>	Tola
<b>GN</b>	Grain	<b>baht</b>	Baht

<sup>1)</sup> factory setting

<sup>2)</sup> not with 0.01 mg, 0.1 mg and 1 mg balances

<sup>3)</sup> with 0.01 mg, 0.1 mg and 1 mg balances

<sup>4)</sup> the Malaysian tael has the same value

### "UNIT 2" – Weight Unit 2

If it is required to show the weighing results in weighing mode in an additional unit, the desired second weight unit can be selected in this menu topic (depending on the model). Units see **"UNIT 1"**. Select **"NO"**, if you do not want to use **"UNIT 2"**.

**Note:** Only those weight units allowed by the appropriate national legislation are selectable.

### "KEY BEEP" – Key Beep

This menu topic allows you to select the volume of the key beep. The according key beep is emitted during the setting.

<b>"MED"</b>	Medium level <b>(Factory setting)</b>
<b>"HIGH"</b>	High level
<b>"OFF"</b>	Beep switched off
<b>"LOW"</b>	Low level

### "STAB.BEEP" – Stability Beep

If the unstable symbol disappears, the stability beep becomes active. This menu topic allows you to preselect the volume of the stability beep.

"MED"	Medium level ( <b>Factory setting</b> )
"HIGH"	High level
"OFF"	Beep switched off
"LOW"	Low level

### "RESET" – Reset Balance Settings

This menu topic allows you to call-up the factory settings.

To toggle between "YES?" and "NO?" press  (or «+» or «-»).

**Note:** A reset of the balance will not change the "DATE", "TIME" and "ZERO RNG" settings.

## 6.3.3 Advanced Menu

### "WEIG.MODE" – weighing mode settings

This setting can be used to adapt the balance to the weighing mode.



"UNIVERS."	For all standard weighing applications. ( <b>Factory setting</b> )
"DOSING"	For dosing liquid or powdery products. With this setting, the balance responds very quickly to the smallest changes in weight.

### "ENVIRON." – Environment Settings

This setting can be used to match your balance to the ambient conditions.

"STANDARD"	Setting for an average working environment subject to moderate variations in the ambient conditions. ( <b>Factory setting</b> )
"UNSTABLE"	Setting for a working environment where the conditions are continuously changing.
"STABLE"	Setting for a working environment which is practically free from drafts and vibrations.

### "CAL" – Adjustment (calibration)

In this menu topic you can preselect the function of the  key. Your balance can be adjusted with internal or external weights by pressing the  key. If you have attached a printer to your balance, the data of the adjustment (calibration) are printed out.

"ADJ.OFF"	The adjustment is <b>switched off</b> . The  key has no function.
"ADJ.INT"	<b>Internal</b> adjustment: adjustment is performed at a keystroke with the built-in weight (depending on the model, see technical data).
"ADJ.EXT"	<b>External</b> adjustment: adjustment is performed at a keystroke with a selectable external weight.
"100.00 g"	<b>Defining the external adjustment weight:</b> define the weight of the external adjustment weight (in grams). <b>Factory setting:</b> depends on the model.

### "ADJ.CUST.F" – Customer fine adjustment

At this menu topic you can fine-adjust the internal weights. Further information refer to chapter Customer Fine Adjustment.

"EXECUTE"	Start customer fine adjustment "ADJ.CUST.F".
"RESET"	Deactivate customer fine adjustment after confirming with <b>YES?</b>
<b>NO?</b>	No deactivation.
<b>YES?</b>	Confirm to deactivation.

### "FACT" – Fully Automatic Adjustment

Fully automatic internal adjustment (calibration) **FACT** (Fully Automatic Calibration Technology) provides fully automatic balance adjustment based on temperature criteria and on preselected time. (depending on the model, see technical data)

"TIME"	Execute FACT (with selected time).
"12:00"	Specify the time for a fully automatic adjustment to take place every day. <b>Factory setting:</b> 12:00 (according to time format)
"OFF"	FACT is <b>switched off</b> .

### "FACT PRT." – Protocol Trigger for Fact

This setting specifies whether an adjustment report should be printed automatically.

**Note:** This menu topic does not affect the printing of adjustments with an internal or external adjustment weight.

"OFF"	<b>Protocol switched off:</b> if the balance adjusts automatically (FACT), a protocol is not printed out.
"ON"	Protocol switched on: a record is printed out after every automatic adjustment of the balance (FACT). <b>Note:</b> The protocol is printed out without a line for signatures.

### "DATE.FORM" – Date Format

This menu topic allows you to preselect the date format.

The following date formats are available:

	Display examples	Printing examples
"DD.MM.Y"	01.02.2009	01.02.2009
"MM/DD/Y"	02/01/09	02/01/2009
"Y-MM-DD"	09-02-01	2009-02-01
"D.MMM Y"	1.FEB.09	1.FEB 2009
"MMM D Y"	FEB.1.09	FEB 1 2009

**Factory setting:** "DD.MM.Y"

### "TIME.FORM" – Time Format

This menu topic allows you to preselect the time format.

The following date formats are available:

	Display examples
"24:MM"	15:04
"12:MM"	3:04 PM
"24.MM"	15.04
"12.MM"	3.04 PM

**Factory setting:** "24:MM"

### "RECALL" – Recall

This menu topic allows you to switch the "RECALL" function on or off. When it is switched on recall stores the last stable weight if the absolute display value was bigger than 10d.

"OFF"	"RECALL" switched off ( <b>Factory setting</b> )
"ON"	"RECALL" switched on

**Note:** The recall value is displayed with an asterisk and cannot be printed.

### "SHUTOFF" – Automatic Shutoff

If the automatic shutoff function is activated, the balance automatically switches itself off after a preselected time of inactivity (i.e. with no key being pressed or changes of weight occurring etc.) and is switched to the standby mode.

"A.OFF 10" min	Automatic shutoff after <b>10 minutes</b> of inactivity. ( <b>Factory setting</b> )
"A.OFF –"	Automatic shutoff <b>not</b> activated.
"A.OFF 2" min	Automatic shutoff after <b>2 minutes</b> of inactivity.
"A.OFF 5" min	Automatic shutoff after <b>5 minutes</b> of inactivity.

### "BCKLIGHT" – Backlight

Under this menu topic, the display backlight can be switched off automatically. If the automatic switch-off is activated, the backlight will turn off automatically after the selected period of inactivity has elapsed. The backlight is reactivated when a key is pressed or the weight is changed.

"B.L. ON"	Backlight is always <b>on</b> . ( <b>Factory setting</b> )
"B.L. 30" s	Automatic switch-off after <b>30 seconds</b> inactivity.
"B.L. 1" min	Automatic switch-off after <b>1 minute</b> inactivity.
"B.L. 2" min	Automatic switch-off after <b>2 minutes</b> inactivity.
"B.L. 5" min	Automatic switch-off after <b>5 minutes</b> inactivity.

### "DISPLAY" – Display Settings

This menu topic allows you to adjust brightness and contrast of the display.

"BRIGHTN"	To set the brightness in 1% steps.
"50%"	<b>Factory setting:</b> 50%
"CONTRAST"	To set the contrast in 1% steps.
"75%"	<b>Factory setting:</b> 75%

### "AUTOZERO" – Automatic Zero Setting

This menu topic allows you to switch the automatic zero setting on or off.

"ON"	" <b>AUTOZERO</b> " <b>switched on</b> ( <b>Factory setting</b> ). The automatic zero setting continuously corrects possible variations in the zero point that might be caused through small amounts of contamination on the weighing pan.
"OFF"	" <b>AUTOZERO</b> " <b>switched off</b> . The zero point is not automatically corrected. This setting is advantageous for special applications (e.g. evaporation measurements).

**Note:** With approved balances, this setting is not available (only available in selected countries).

### "ZERO RNG" – Zero Range

This menu topic allows you to set a zero limit for the «→0/T←» key. Up to and including this limit the «→0/T←» key will execute a zero. Above this limit the «→0/T←» key will execute a tare.

"1.2 g"	To set the upper limit of the zero setting range as weight in the definition unit of the balance. ( <b>Factory setting:</b> 0.5% of weighing range)
---------	--------------------------------------------------------------------------------------------------------------------------------------------------------

**Note:** With approved balances, this setting is not available and fixed to 3e (only available in selected countries).

**Note:** A reset of the balance will not change this setting.

## "LANGUAGE" – Language

**Factory setting:** Generally, the language of the destination country (if available) or English is set.

The following languages are available:

"ENGLISH"	English	"POLSKI"	Polish
"DEUTSCH"	German	"CESKY"	Czech
"FRANCAIS"	French	"MAGYAR"	Hungarian
"ESPANOL"	Spanish	"NEDERL."	Dutch
"ITALIANO"	Italian	"BR.PORTUG."	Brazil Portuguese
"RUSSIAN" РУССКИЙ	Russian		

## "ASSIGN:F1" – Assign Application Key F1

At this menu topic you can assign an application to the «F1» key. The following applications are available (depending on the model):

"COUNTING"	Piece counting ( <b>Factory setting</b> )
"PERCENT"	Percent weighing
"STAT"	Statistics
"FORMULA"	Formulation / Net-Total
"TOTALING"	Totaling
"FACTOR M"	Multiplication factor
"FACTOR D"	Division factor
"DENSITY"	Density
"PIPETTE"	Pipette check

## "ASSIGN:F2" – Assign Application Key F2

At this menu topic you can assign an application to the «F2» key. The following applications are available (depending on the model):

"PERCENT"	Percent weighing ( <b>Factory setting</b> )
"STAT"	Statistics
"FORMULA"	Formulation / Net-Total
"TOTALING"	Totaling
"FACTOR M"	Multiplication factor
"FACTOR D"	Division factor
"DENSITY"	Density
"PIPETTE"	Pipette check
"COUNTING"	Piece counting

## "ASSIGN:F3" – Assign Application Key F3

At this menu topic you can assign an application to the «F3» key. The following applications are available (depending on the model):

"STAT"	Statistics ( <b>Factory setting</b> )
"FORMULA"	Formulation / Net-Total
"TOTALING"	Totaling
"FACTOR M"	Multiplication factor
"FACTOR D"	Division factor
"DENSITY"	Density
"PIPETTE"	Pipette check
"R. TEST"	Routine test

"COUNTING"	Piece counting
"PERCENT"	Percent weighing

### "DIAGNOSE" – Diagnostics Application

At this menu topic you can start a diagnostic application. For more information see chapter application "Diagnostics".

The following diagnostics are available:

"REPEAT.T"	Repeatability test (models with internal weights only)
"DISPLAY"	Display test
"KEYPAD T"	Key test
"CAL.MOT. T"	Motor test (models with internal weights only)
"BAL.HIST"	Balance history
"CAL.HIST"	Calibration history
"BAL.INFO"	Balance information
"PROVIDER"	Service provider information

### "SERV.ICON" – Service Reminder

This menu topic allows you to switch the service reminder "🔧" on or off.

"ON"	Service reminder "🔧" <b>switched on</b> (factory setting). You will be informed after a preset time (e.g. one Year or 8000 operating hours) to call service for recalibration. This will be indicated by the flashing service icon: "🔧". <b>(Factory setting)</b>
"OFF"	Service reminder "🔧" <b>switched off</b> .

### "SRV.D.RST" – Service Date Reset

This menu topic allows you to reset service date and hours.



**Note:** This menu topic is only available if "SERV.ICON" setting "ON" was selected.







To toggle between "YES?" and "NO?" press «» (or «+» or «-»)

## 6.3.4 Interface Menu

### "RS232" – RS232C Interface <sup>1)</sup>

At this menu topic you can select the peripheral device connected to the RS232C interface and specify how the data is transmitted.

"PRINTER"	Connection to a <b>printer</b> . <b>(Factory setting)</b> <b>Note:</b> <ul style="list-style-type: none"> <li>• Only one printer possible.</li> <li>• See recommended printer settings found in section "Appendix", as well as the printer-specific user's manual.</li> </ul>
"PRT.STAB"	If the «  » key is pressed, the next stable weight value will be printed. <b>(Factory setting)</b>
"PRT.AUTO"	Every stable weight value will be printed, without pressing the «  » key.
"PRT.ALL"	If the «  » key is pressed, the weight value will be printed regardless of stability.
"PC-DIR."	Connection to a <b>PC</b> : the balance can send data (as a Keyboard) to the PC used for PC applications e.g. Excel. <b>Note:</b> The balance sends the weight value without the unit to the PC.

"PRT.STAB"	If the «  » key is pressed, the next stable weight value will be sent followed by an enter. ( <b>Factory setting</b> )
"PRT.AUTO"	Every stable weight value will be sent followed by an enter, without pressing the «  » key.
"PRT.ALL"	If the «  » key is pressed, the weight value will be sent followed by an enter regardless of stability.
"HOST"	Connection to a <b>PC</b> , Barcode Reader etc.: the balance can send data to the PC and receive commands or data from the PC).
"SEND.OFF"	Send mode switched off. ( <b>Factory setting</b> )
"SEND.STB"	If the «  » key is pressed, the next stable weight value will be sent.
"SEND.CONT"	All weight value updates will be sent regardless of stability, without pressing the «  » key.
"SEND.AUTO"	Every stable weight value will be sent, without pressing the «  » key.
"SEND.ALL"	If the «  » key is pressed, the weight value will be sent regardless of stability.
"2.DISPLAY"	Connection of an <b>optional auxiliary display</b> unit <b>Note:</b> The transmission parameters cannot be selected. Settings are automatically set.



**Attention:**

- If you select 2nd Display "**2.DISPLAY**", first make sure that no other device is connected at COM1 as a 2nd display. Other devices could be damaged because of the voltage on connector Pin 9. Necessary for powering the 2nd display (see chapter "Interface Specification")

**"HEADER" – Options for the Printout Header of individual values**

This menu topic allows you to specify the information that is to be printed at the top of the printout for every individual weighing results (after pressing «»).

**Note:** This menu topic is only available if "**PRINTER**" setting was selected.

"NO"	The header is not be printed ( <b>Factory setting</b> )
"DAT / TIM"	Date and time are printed
"D / T / BAL"	Date, time and balance information (Balance type, SNR, Balance ID) are printed.

**Note:** Balance ID only if set.

**"SINGLE" – Options for Printing out the Result of individual values**

This menu topic allows you to specify the information that is to be printed for every individual weighing result (after pressing «»).

**Note:** This menu topic is only available if "**PRINTER**" setting was selected.

"NET"	The value of the Net weight from the current weighing is printed ( <b>Factory setting</b> )
"G / T / N"	The values of the Gross weight, the Tare weight and the Net weight are printed

**"SIGN.L" – Options for the Printout Footer for Signature Line of individual values**

This menu topic allows you to set a footer for signature at the bottom of the printout for every individual weighing result (after pressing «»).

**Note:** This menu topic is only available if "**PRINTER**" setting was selected.



"OFF" The signature footer is not be printed. (**Factory setting**)  
 "ON" The signature footer is printed

**"LINE.FEED" – Options for Complete the Printout of individual values**

This menu topic allows you to specify the number of blank lines to complete the printout (line feed) for every individual weighing result (after pressing «»).

**Note:** This menu topic is only available if "PRINTER" setting was selected.

"0" Possible numbers of blank lines: 0 to 99 (**Factory setting = 0**)

**"ZERO PRT." – Options for "PRT.AUTO" <sup>1)</sup>**

This menu topic allows you to specify the auto print function "PRT.AUTO" for printing zero "YES" or "NO".

"OFF" Zero is not be printed (Zero +/- 3d) (**Factory setting**)  
 "ON" Zero is always printed

**Note:** This menu topic is only available if "PRT.AUTO" fuction of the "PRINTER" or "PC-DIR." was selected.

**"COM.SET" – Options for the Data Communication Format (RS232C)("HOST") <sup>1)</sup>**

This menu topic allows you to set the data format depending on which peripheral device is connected.

**Note:** This menu topic is only available if "HOST" setting was selected.

"MT-SICS" The MT-SICS data transfer formats is used. (**Factory setting**)  
 For more information see section "MT-SICS Interface Commands and Functions".

"MT-PM" The following PM balance commands are supported:

- S Send value
- SI Send immediate value
- SIR Send immediate value and repeat
- SR Send value and repeat
- SNR Send next value and repeat
- T Tare
- TI Tare immediately
- B Base \*)
- MI Modify ambient vibration
- MZ Modify Auto Zero
- M Modified settings reset
- ID Identify
- CA Calibrate
- D Display (only symbol N and G available)

\*) Limitation:

- Negative values are limited up to the current tare value.
- B command is additive.
- The sum of the B values plus the previous tare value, before a "TA", "T" or "Z" is sent, must be less than the total weighing range.

"SART" The following Sartorius commands are supported:

- K Ambient conditions: very stable
- L Ambient conditions: stable
- M Ambient conditions: unstable
- N Ambient conditions: very unstable

O	Block keys
P	Print key (print, auto print; activate or block)
Q	Acoustic signal
R	Unblock keys
S	Restart/self-test
T	Tare key
W	Calibration/adjustment (depending on the menu setting *)
Z	Internal calibration/adjustment **)
f0_	Function key (F)
f1_	Function key (CAL)
s3_	C key
x0_	Perform internal calibration **)
x1_	Print balance/scale model
x2_	Print weighing cell serial number
x3_	Print software version

\*) may be inaccessible on verified balances/scales

\*\*\*) only on models with built-in motorized calibration weight

#### Functionality mapping

<b>"HOST" settings:</b>	<b>Sartorius printer settings:</b>
<b>"SEND.OFF"</b>	not applicable
<b>"SEND.STB"</b>	manually print with stability
<b>"SEND.ALL"</b>	manually print without stability
<b>"SEND.CONT"</b>	automatically print without stability
<b>"SEND.AUTO"</b>	similar applicable to automatically print when load is changed

#### "BAUDRATE" – Baud rate RS232C 1)

This menu topic allows you to match the data transmission to different serial RS232C receivers. The baud rate (data transfer rate) determines the speed of transmission via the serial interface. For problem-free data transmission the sending and receiving devices must be set at the same value.

The following settings are available:

600 bd, 1200 bd, 2400 bd, 4800 bd, 9600 bd, 19200 and 38400 bd. (default: **9600 bd**)

#### Note:

- Not visible for 2nd display.
- Each device has separate settings.

#### "BIT/PAR." – Bit/Parity RS232C 1)

At this menu topic you can set the character format for the attached RS232C serial peripheral device.

<b>"8/NO"</b>	8 data bits/no parity ( <b>Factory setting</b> )
<b>"7/NO"</b>	7 data bits/no parity
<b>"7/MARK"</b>	7 data bits/mark parity
<b>"7/SPACE"</b>	7 data bits/space parity
<b>"7/EVEN"</b>	7 data bits/even parity
<b>"7/ODD"</b>	7 data bits/odd parity

#### Note:

- Not visible for 2nd display.
- Each device has separate settings.

#### "STOPBIT" – Stop Bits RS232C <sup>1)</sup>

At this menu topic you can set the stop bits of the transmitted data to different RS232C serial receivers.

"1 BIT"	1 Stop bit ( <b>Factory setting</b> )
"2 BITS"	2 Stop bits

#### "HD.SHAKE" – Handshake RS232C <sup>1)</sup>

This menu topic allows you to match the data transmission to different RS232C serial receivers.

"XON/XOFF"	Software handshake (XON/XOFF) ( <b>Factory setting</b> )
"RTS/CTS"	Hardware handshake (RTS/CTS)
"OFF"	No handshake

#### Note:

- Not visible for 2nd display.
- Each device has separate settings.

#### "RS.TX.E.O.L." – End of Line RS232C <sup>1)</sup>

At this menu topic you can set the "End of Line" character of the transmitted outgoing data to different RS232C serial receivers.

"(CR)(LF)"	<CR><LF> Carriage Return followed by Line feed (ASCII-Codes 013+010) ( <b>Factory setting</b> )
"(CR)"	<CR> Carriage Return (ASCII-Code 013)
"(LF)"	<LF> Line feed (ASCII-Code 010)
"(TAB)"	<TAB> Tabulator to the right (ASCII-Code 009), only settable if <b>PC-DIR.</b> is selected.

#### Note:

- Not visible for 2nd display.
- Each device has separate settings.

#### "RS CHAR" – Char Set RS232C <sup>1)</sup>

At this menu topic you can set the "Character Set" of the transmitted data to different RS232C serial receivers.

"IBM/DOS"	Char Set IBM/DOS ( <b>Factory setting</b> )
"ANSI/WIN"	Char Set ANSI/WINDOWS

#### Note:

- Not visible for 2nd display.
- Each device has separate settings.









#### "USB" – USB Interface

At this menu topic you can select the mode of the "USB Device" interface and specify how the data is transmitted.

#### Note:

- DISCONNECT THE USB CONNECTION FROM THE BALANCE PRIOR TO CHANGE THE SETTINGS.
- This port is not usable for printers or displays.

"PC-DIR."	Connection to a <b>PC</b> : the balance can send data (as a Keyboard) to the PC used for PC applications e.g. Excel. <b>Note:</b> The balance sends the weight value without the unit to the PC.
-----------	-----------------------------------------------------------------------------------------------------------------------------------------------------------------------------------------------------

"SEND.OFF"	Send mode switched off <b>(Factory setting)</b>
"SEND.STB"	If the «  » key is pressed, the next stable weight value will be sent.
"SEND.CONT"	All weight value updates will be sent regardless of stability, without pressing the «  » key.
"SEND.AUTO"	Every stable weight value will be sent, without pressing the «  » key.
"SEND.ALL"	If the «  » key is pressed, the weight value will be sent regardless of stability.
"HOST"	Connection to a <b>PC</b> , Barcode Reader etc.: the balance can send data to the PC and receive commands or data from the PC).
"SEND.OFF"	Send mode switched off. <b>(Factory setting)</b>
"SEND.STB"	If the «  » key is pressed, the next stable weight value will be sent.
"SEND.CONT"	All weight value updates will be sent regardless of stability, without pressing the «  » key.
"SEND.AUTO"	Every stable weight value will be sent, without pressing the «  » key.
"SEND.ALL"	If the «  » key is pressed, the weight value will be sent regardless of stability.

#### "USB COM.S." – Options for the Data Communication Format (USB)

This menu topic allows you to set the data format depending on which peripheral device is connected.

"MT-SICS"	The MT-SICS data transfer formats is used. <b>(Factory setting)</b> For more information see section "MT-SICS Interface Commands and Functions".
"MT-PM"	The following PM balance commands are supported: S        Send value SI        Send immediate value SIR      Send immediate value and repeat SR        Send value and repeat SNR      Send next value and repeat T        Tare TI        Tare immediately B        Base *) MI        Modify ambient vibration MZ        Modify Auto Zero M        Modified settings reset ID        Identify CA        Calibrate D        Display (only symbol N and G available) *) Limitation: <ul style="list-style-type: none"> <li>• Negative values are limited up to the current tare value.</li> <li>• B command is additive.</li> <li>• The sum of the B values plus the previous tare value, before a "TA", "T" or "Z" is sent, must be less than the total weighing range.</li> </ul>

## "SART"

The following Sartorius commands are supported:

K	Ambient conditions: very stable
L	Ambient conditions: stable
M	Ambient conditions: unstable
N	Ambient conditions: very unstable
O	Block keys
P	Print key (print, auto print; activate or block)
Q	Acoustic signal
R	Unblock keys
S	Restart/self-test
T	Tare key
W	Calibration/adjustment (depending on the menu setting *)
Z	Internal calibration/adjustment **)
f0_	Function key (F)
f1_	Function key (CAL)
s3_	C key
x0_	Perform internal calibration **)
x1_	Print balance/scale model
x2_	Print weighing cell serial number
x3_	Print software version

\*) may be inaccessible on verified balances/scales

\*\*\*) only on models with built-in motorized calibration weight

### Functionality mapping

"HOST" settings:	Sartorius printer settings:
"SEND.OFF"	not applicable
"SEND.STB"	manually print with stability
"SEND.ALL"	manually print without stability
"SEND.CONT"	automatically print without stability
"SEND.AUTO"	similar applicable to automatically print when load is changed

## "USB E.O.L." – End of Line USB

At this menu topic you can set the "End of Line" character of the transmitted data to USB device.

"(CR)(LF)"	<CR><LF> Carriage Return followed by Line feed (ASCII-Codes 013+010) <b>(Factory setting)</b>
"(CR)"	<CR> Carriage Return (ASCII-Code 013)
"(LF)"	<LF> Line feed (ASCII-Code 010)
"(TAB)"	<TAB> Horizontal tab (ASCII-Code 011), only settable if <b>PC-DIR.</b> is selected.

## "USB CHAR" – Char Set USB

At this menu topic you can set the "Character Set" of the transmitted data to USB device.

"ANSI/WIN"	Char Set ANSI/WINDOWS <b>(Factory setting)</b>
"IBM/DOS"	Char Set IBM/DOS

### "INTERVAL" – Print Key Simulation

At this menu topic you can activate a simulation of the  key. "INTERVAL" simulates a print key press every x seconds.

Range:	0 to 65535 seconds
0 sec:	disables the print key simulation

**Factory setting:** 0 sec

**Note:** The executed action is according to the configuration of the print key. (see interface setting)

### "ERGOSENS" – Settings for external key

The METTLER TOLEDO "ErgoSens" or external contact switches (optional, see section accessories) can be connected to the "Aux" connection and these can be used to execute certain weighing functions.

"OFF"	Deactivate ( <b>Factory setting</b> )
"->0<-"	Zero setting
"->T<-"	Taring
"PRINT"	Print 

---

#### 1) Note for 2nd RS232C Interface

- If an optional 2nd interface is installed, the menu topic is displayed for each interface, e.g  
"BAUDRATE.1" for standard interface  
"BAUDRATE.2" for optional 2nd interface
  - Only one printer can be set if two RS232 interfaces are existing.
-

## 7 Applications

### 7.1 Application "Piece Counting"

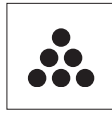

The "**Piece Counting**" application allows you to determine the number of pieces put on the weighing pan.

**Requirement:** The function "**COUNTING**" must be assigned to an «Fx» key (see advanced menu topic "**ASSIGN:Fx**", factory setting: F1).



- Activate function "**COUNTING**" by pressing and holding the appropriate assigned «Fx» key (factory setting: F1).

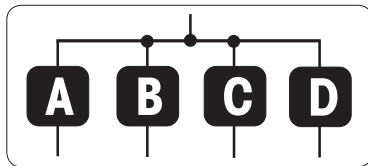

**Piece Counting first requires the setting of a reference weight, there are 4 possibilities:**

- A** Setting the reference **by multiple pieces with fix reference values.**
- B** Setting the reference **by multiple pieces with variable reference values.**
- C** Setting the reference **for 1 piece in weighing mode.**
- D** Setting the reference **for 1 piece in manual mode.**

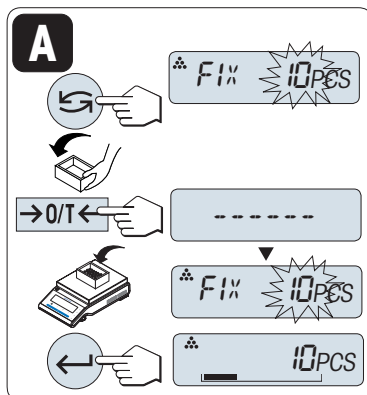

Setting possibility

#### **A** Setting the reference by multiple pieces with fix reference values

- 1 Select a number of reference pieces by scrolling with «←». Possible numbers\* are 5, 10, 20 and 50.  
\* with approved balances in selected countries: min 10
- 2 Press «→0/T←» to tare. If using: place empty container on the weighing pan first or tare again.
- 3 Add the selected number of reference pieces to container.
- 4 Press «←» to confirm.

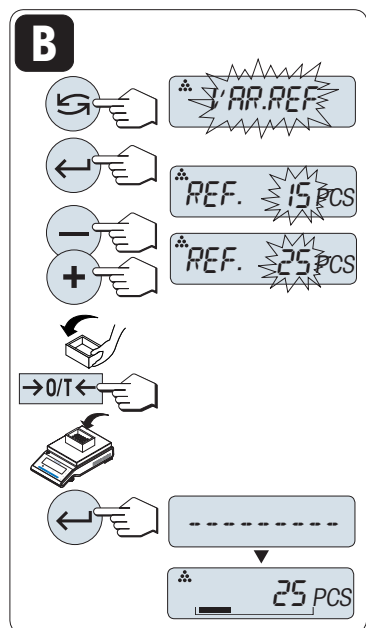

Setting possibility

#### **B** Setting the reference by multiple pieces with variable reference values

- 1 Select "**VAR.REF**" by scrolling with «←». Press «←» to confirm.
- 2 Select a number of reference pieces by scrolling up («+» key) or down («-» key). Speed up by press and hold. Possible numbers\* are 1 to 999.  
\* with approved balances in selected countries: min 10
- 3 Press «→0/T←» to tare. If using: place empty container on the weighing pan first or tare again.
- 4 Add the selected number of reference pieces to container.
- 5 Press «←» to confirm.

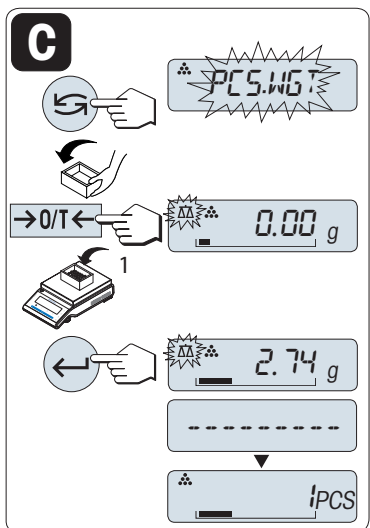

Setting possibility

### **C** Setting the reference for one piece in weighing mode

- 1 Select "**PCS.WGT**" by scrolling with «←».
- 2 Press «→0/T←» to tare. If using: place empty container on the weighing pan first or tare again.
- 3 Add one reference piece to container. The weight of one piece is displayed.
- 4 Press «←» to confirm.

**Note:** With approved balances, this setting is not available in selected countries.

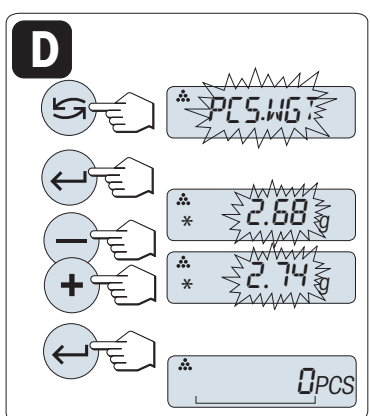

Setting possibility

### **D** Setting the reference for one piece in manual mode

- 1 Select "**PCS.WGT**" by scrolling with «←».
- 2 Press «←» to confirm.
- 3 Enter the final reference one piece weight by scrolling up («+» key) or down («-» key). Speed up by press and hold.
- 4 Press «←» to confirm.

**Note:** With approved balances, this setting is not available in selected countries.

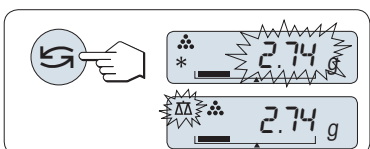

### Switching between manual mode and weighing mode

- Press «←» to switch between manual and weighing mode.

**Note:** By switching from weighing mode to manual mode the weight value will be transferred and can be changed manually.

**Note:** If without any key press within 60 seconds, the balance returns to the previous active application. Press «C» to cancel and returns to the previous active application.

**On completion of the setting procedure, your balance is ready for piece counting.**

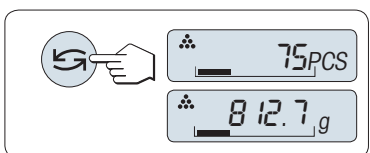

### Switching between piece count and weight display.

You can use the «←» key at any time to switch the display between piece display, weighing unit "**UNIT 1**", "**RECALL**" value (if activated) and weighing unit "**UNIT 2**" (if different from "**UNIT 1**").

**Note:**

- The "**RECALL**" value is displayed with an asterisk (\*) and icon "M" and can not be printed.
- Take into account minimum values: min. reference weight = 10d (10 digits), min. piece weight\* = 1d (1 digit)!  
\* with approved balances in selected countries: min 3e
- The current reference weight remains stored until the reference setting is changed.



**Terminate the application**

Press and hold «» to terminate the application and to return to the weighing application.

## 7.2 Application "Percent Weighing"

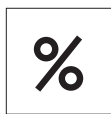

The **"Percent Weighing"** application allows you to check a sample weight as percentage to a reference target weight.

**Requirement:** The function **"PERCENT"** must be assigned to an «Fx» key (see advanced menu topic **"ASSIGN:Fx"**, factory setting: F2).



- Activate function percent weighing **"PERCENT"** by pressing and holding the appropriate assigned «Fx» key (factory setting: F2).

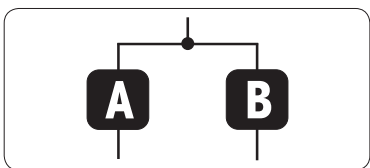

**Percent Weighing first requires the setting of a reference weight that should corresponds to 100%, there are 2 possibilities:**

- A** Setting the reference **in manual mode (enter 100%)**.
- B** Setting the reference **in weighing mode (weigh 100%)**.

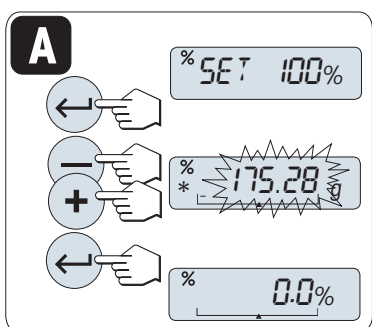

Setting possibility

### **A** Setting the reference by manual mode (enter 100%)

- 1 Press «←» to activate manual mode.
- 2 Select the reference target weight (100%) by scrolling up («+») or down («-») key. Speed up by press and hold.
- 3 Press «←» to confirm.

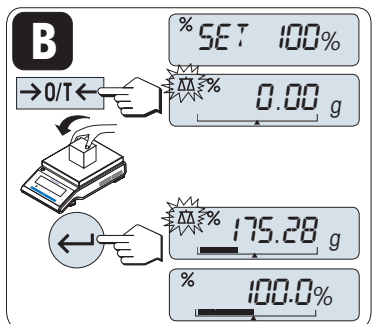

Setting possibility

### **B** Setting the reference by weighing mode (weigh 100%)

- 1 Press «→0/T←» to tare the balance and to activate the weighing mode. If needed: place empty container on the weighing pan and tare again.
- 2 Load the reference weight (100%).  
**Note:** Reference weight must be at least +/- 10d.
- 3 Press «←» to confirm.

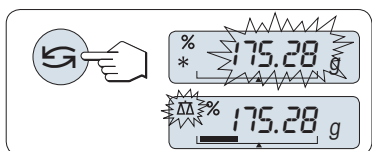

### **Switching between manual mode and weighing mode**

- Press «↻» to switch between manual and weighing mode.

**Note:** By switching from weighing mode to manual mode the weight value will be transferred and can be changed manually.

**Note:** If without any key press within 60 seconds, the balance returns to the previous active application.

**On completion of the weighing-in procedure, your balance is ready for percent weighing.**

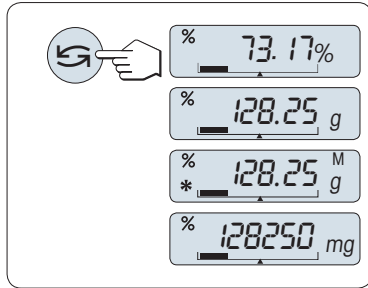

### Switching between percent and weight display

You can use the «» key at any time to switch the display between percent display, weighing unit "UNIT 1", "RECALL" value (if activated) and weighing unit "UNIT 2" (if different from UNIT 1).

#### Note:

- The recall value is displayed with an asterisk (\*) as well as icon "M" and can not be printed.
- The current set weight remains stored until it is redetermined.

### Terminate the application

Press and hold «» to terminate the application and to return to the weighing application.

## 7.3 Application "Statistics"



The "Statistics" application allows you to generate statistics of a series of weighing values. 1 to 999 values are possible.

**Requirement:** The function "STAT" must be assigned to an «Fx» key (see advanced menu topic "ASSIGN:Fx"). Connect a printer or a PC if present.

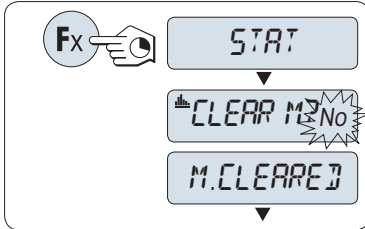

- 1 Activate function "STAT" by pressing and holding the appropriate assigned «Fx» key.
- 2 To continue the last statistics press «←|». For a new statistical evaluation press «↶» to select "Yes" and press «←|» to clear the memory.

**Note:**

If the memory is already cleared (at the first start of this application or sample counter is 0) the memory clear question will be not displayed.

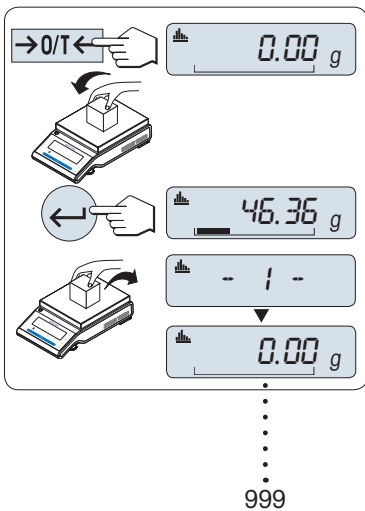

**Weighing the first sample weight:**

- 1 Press «→0/T←» to zero/tare the balance if needed.
- 2 Load the first sample weight.
- 3 Press «←|». The display shows the sample count "- 1 -" and the current weight is stored as sample and the weight is printed out.  
**Note:** When the sample counter is displayed you may press «C» to undo (drop) this sample.
- 4 Unload the first sample weight.

**Weighing further sample weights:**

The same procedure as for the first sample weight.

- 1...999 samples are possible.
- The next value will be accepted if the sample weight is in the range 70% –130% of the current average value. "OUT OF RANGE" will be displayed if the sample is not accepted.

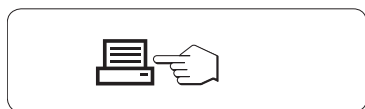

**Results:**



- If the numbers of sample are greater than or equal to 2, press «≡», the results are displayed and printed.

**Displayed results:**

- 1 Press «←|» to show the next statistical value.
- 2 Press «C» to cancel displaying results and to continue weighing next sample.

		0.5 seconds
number of samples		
average		
standard deviation		
relative standard deviation		
lowest value (minimum)		
highest value (maximum)		

### Displayed results:

- 1 Press «» to show the next statistical value.
- 2 Press «» to cancel displaying results and to continue weighing next sample.

different between the minimum  
and the maximum  
sum of all values

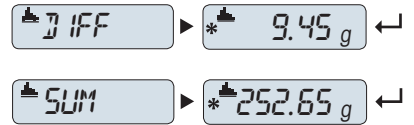

### Printout:

```
----- Statistics -----
21.Jan 2009      12:56

METTLER TOLEDO

Balance Type      MS4002S
SNR               1234567890
-----
1                46.36 g
2                55.81 g
3                47.49 g
4                53.28 g
5                49.71 g
n                5
x                50.530 g
s dev           3.961 g
s rel           7.84 g
Min.            46.36 g
Max.            55.81 g
Diff            9.45 g
Sum             252.65 g
-----
```

### Terminate the application

Press and hold «» to terminate the application and to return to the weighing application.

## 7.4 Application "Formulation" (Net Total Formulation)



The **"Formulation"** (Net Total) application allows you to

- weigh in (add and store) up to 999 individual component weights and displays the total. If a printer is connected, the component weights are printed individually and as a total.
- tare/pre-tare and store up to 999 container weights and displays the total. If a printer is connected, the tare weights are printed out individually and as a total.
- fill up the sum of all component net weight values by adding a further component to a higher value.

**Requirement:** The function **"FORMULA"** must be assigned to an **«Fx»** key (see advanced menu topic **"ASSIGN:Fx"**). Connect a printer or a PC if present.

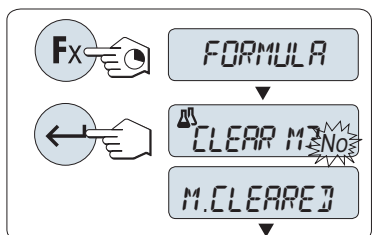

- 1 Activate function formulation **"FORMULA"** by pressing and holding the appropriate assigned **«Fx»** key.
- 2 Press **«←»** to continue formulation weighing. For a new formulation press **«↺»** (or **«+»** or **«-»**) to select "Yes" and press **«←»** to clear the memory.

**Note:** If the memory is already cleared (sample and tare/pre-tare counter is zero) the memory clear question will be not displayed.

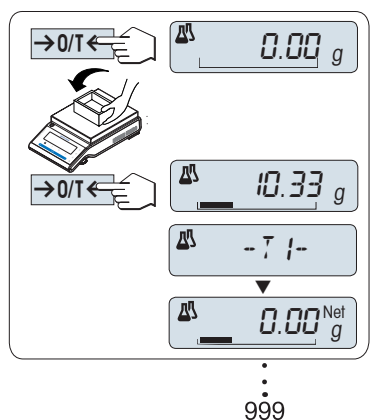

**Tare container** (if used):

- 1 Press **«→0/T←»** to zero or tare the balance if needed.
- 2 Place the empty container on the weighing pan.
- 3 Press **«→0/T←»**. The container is tared and the tare count "- T 1 -" is displayed and the tare weight is printed.

**Note:**

- If you pre-tare via MT-SICS (e.g. bar code reader) "- PT 1 -" is displayed.
- Zero range setting (menu topic **"ZERO RNG"**) has no effect. The zero-limit is less than or equal 10d.

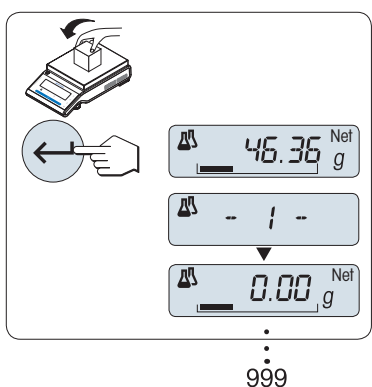

**Weighing the first component weight:**

- 1 Load the first component weight.
- 2 Press **«←»**. The display briefly shows the component count "- 1 -", the current weight is stored as sample and the component weight is printed. The display is set back to zero.

**Weighing further component weights:**

The same procedure as for the first component weight with the same or new container).

- 1...999 sample values are possible.
- max 999 tare values are possible.
- max 999 pre-tare values are possible.

**Results:**



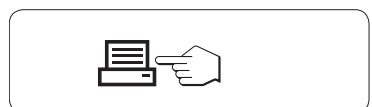



- If the numbers of sample are greater than or equal to 2, press **«≡»**, the results are displayed and printed.

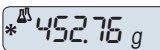

### Displayed results:

- 1 Press «←J» to show the next statistical value.
- 2 Press «C» to cancel displaying results and to continue weighing next component.

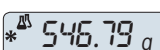
0.5 seconds

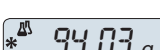
number of samples		* 	←
sum of all tare values (T and PT)		* 	←
sum of all component gross weight values		* 	←
sum of all component net weight values		* 	←

### Printout:

```

----- Formulation -----
21.Jan 2009          12:56

METTLER TOLEDO

Balance Type      MS4002S
SNR               1234567890
-----
1 T                10.33 g
1 N                8.85 g
2 N                9.23 g
2 T                10.84 g
3 N                7.43 g
.
.
n                  8
T Total           452.76 g
G Total           546.79 g

N Total           94.03 g
-----

```

### Function "FILL UP"

This function allows you to add an additional component weight to the total weight of all components to reach a desired target weight (Fill up).

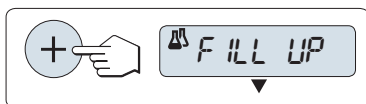

#### Starting the fill up function.

- Activate function "FILL UP" by pressing «+».
- Deactivate function "FILL UP" by pressing «-».

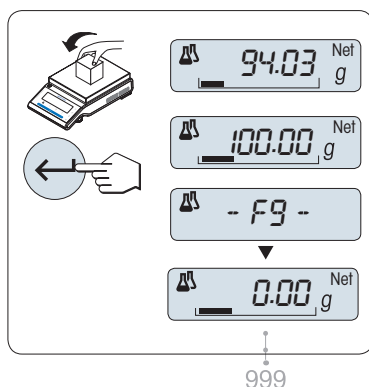

#### Filling up with an additional component weight:

- ▶ The last total of the component weights is displayed.
- 1 Add component weight until the desired target weight is reached.
- 2 Press «←J» to confirm.
- ⇒ The display briefly shows the next component count marked with "F", the current weight is stored as sample and the component weight is printed. The display is set back to zero.

#### Filling up further additional component weights:

The same procedure, beginning with starting up the "FILL UP" function.

**Terminate the application**

Press and hold «» to terminate the application and to return to the weighing application.



## 7.5 Application "Totaling"



The **"TOTALING"** application allows you to weigh in different samples to add their weight values and to totalize them. 1 to 999 samples are possible.

**Requirement:** The function **"TOTALING"** must be assigned to an «Fx» key (see advanced menu topic **"ASSIGN:Fx"**).

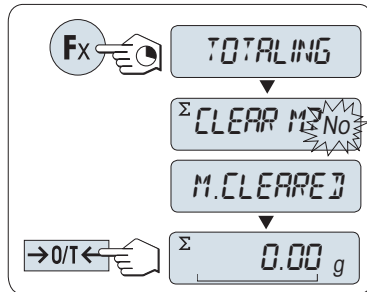

- 1 Activate function **"TOTALING"** by pressing and holding the appropriate assigned «Fx» key.
- 2 For a new totaling evaluation press «» (or «+» or «-») to enter "Yes" and press «» to clear the memory.  
**Note:** If the memory is already cleared (sample counter is 0) the memory clear question will not be displayed.
- 3 Press «0/T» to zero or tare the balance.

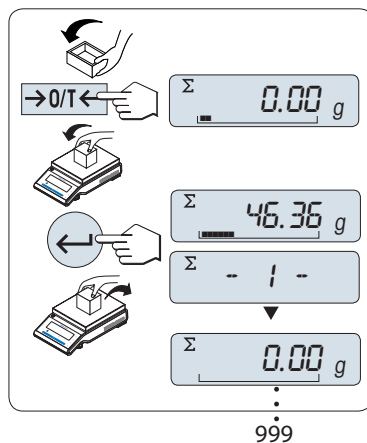

### Weighing in the sample weight:

- 1 If using a container: place empty container on the weighing pan and press «0/T» to zero or tare the balance.
- 2 Load the first sample weight.
- 3 Press «». The display shows the sample count "- 1 -" and the current weight is stored.  
**Note:** When the sample counter is displayed you may press «**C**» to undo (drop) this sample.
- 4 Unload the first sample weight. The display shows zero.

### Weighing in further sample weights:

The same procedure as for the first sample weight.

- 1...999 samples are possible.

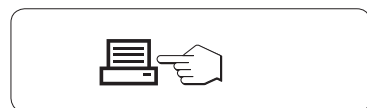

### Results:

- If the numbers of sample are greater than or equal to 2, press «», the results are displayed and printed.

### Displayed results:

- 1 Press «» briefly to show the totalized value.
- 2 Press «**C**» briefly to cancel.

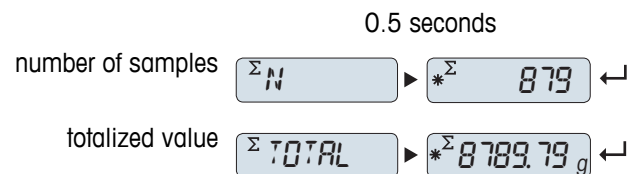

**Printout:**

```
----- Totaling -----  
21.Jan 2009      12:56  
  
METTLER TOLEDO  
  
Balance Type      MS1602S  
SNR                1234567890  
-----  
1                  46.36 g  
2                  55.81 g  
3                  47.49 g  
4                  53.28 g  
5                  49.71 g  
6                  53.93 g  
.  
.  
.  
n                      879  
Total              8789.79 g  
-----
```

**Terminate the application**

Press and hold «» to terminate the application and to return to the weighing application.

## 7.6 Application "Multiplication Factor Weighing"



The "Multiplication Factor Weighing" application allows you to multiply the weight value (in grams) by a predefined factor (result = factor \* weight) and have it calculated to a predefined number of decimal places.

**Requirement:** The function "FACTOR M" must be assigned to an «Fx» key (see advanced menu topic "ASSIGN:Fx").



- Activate function "FACTOR M" by pressing and holding the appropriate assigned «Fx» key.

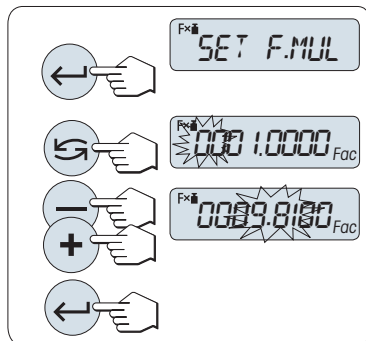

### 1 Setting the factor value:

- 1 Press «←» to execute "SET F.MUL". Either the factor 1 appears as default value or the factor that was saved most recently.
- 2 Press «→» to select a digit. The selected digit is blinking.
- 3 For changing digits, press «+» to scroll up or «-» to scroll down.
- 4 Press «←» to confirm the selected factor (no automatic acceptance).

Note: Zero for multiplication factor value is outside the allowed range, the error message "FACTOR OUT OF RANGE" will be displayed.

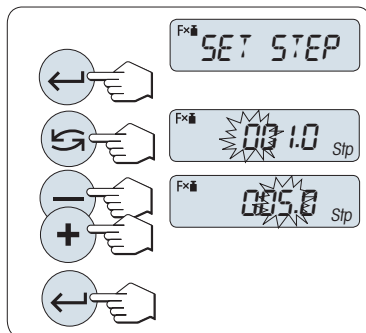

### 2 Setting the step value:

"SET STEP" appears in the display, and the program changes automatically to allow the display increments to be entered. The smallest possible display increment appears as default value, or the last value that was saved.

- 1 Press «←» to execute "SET STEP".
- 2 Press «→» to select a digit. The selected digit is blinking.
- 3 For changing digits, press «+» to scroll up or «-» to scroll down.
- 4 Press «←» to confirm the selected step (no automatic acceptance).

**Note:** The allowed range for the step depends on the factor and the resolution of the balance. If it is outside the allowed range the error message "STEP OUT OF RANGE" will be displayed.

**Note:** If without any key press within 60 seconds, the balance returns to the previous active application. Press «C» to cancel.

**On completion of the setting procedure, your balance is ready for multiplication factor weighing.**

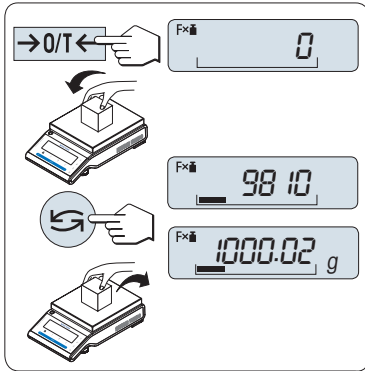

### Weighing procedure

- 1 Press « $\rightarrow 0/T \leftarrow$ » to zero/tare.
- 2 Load sample weight on weighing pan.
- 3 Read the result. The appropriate calculation is then made using the weight of sample and the selected factor, the result being displayed with the selected display step.  
**Note:** No units are displayed.
- 4 Unload sample weight.

### toggling between displaying the calculated value and the measured weight:

You can use the « $\leftarrow$ » key to toggle between the calculated Value, weight value "UNIT 1", "RECALL" value (if selected) and weight value "UNIT 2" (if different from "UNIT 1").

### Terminate the application

Press and hold « $\Delta \Delta$ » to terminate the application and to return to the weighing application.

## 7.7 Application "Division Factor Weighing"



The "Division Factor Weighing" divide a predefined factor by the weight value (in grams) (result = factor / weight) and have it rounded to a predefined number of decimal places.  
**Requirement:** The function "FACTOR D" must be assigned to an «Fx» key (see advanced menu topic "ASSIGN:Fx").



- Activate function "FACTOR D" by pressing and holding the «Fx» key.

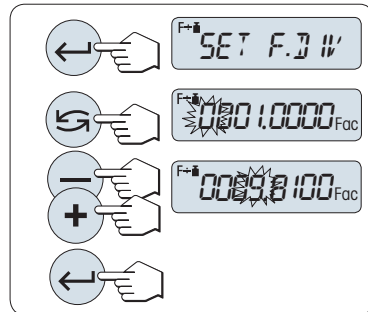

### 1 Setting the Factor Value:

- 1 Press «←» to execute "SET F.DIV". Either the factor 1 appears as default value or the factor that was saved most recently.
- 2 Press «→» to select a digit. The selected digit is blinking.
- 3 For changing digits, press «+» key to scroll up or «-» to scroll down.
- 4 Press «←» briefly to confirm the selected factor (no automatic acceptance).

Note: Zero for division factor value is outside the allowed range, the error message "FACTOR OUT OF RANGE" will be displayed.

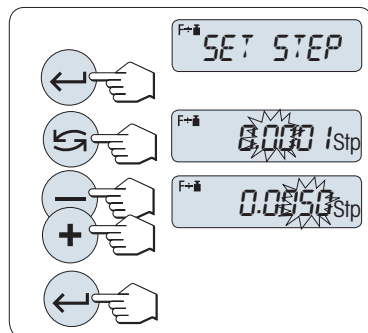

### 2 Setting the step value:

"SET STEP" appears in the display, and the program changes automatically to allow the display increments to be entered. The smallest possible display increment appears as default value, or the last value that was saved.

- 1 Press «←» to execute "SET STEP".
- 2 Press «→» to select a digit. The selected digit is blinking.
- 3 For changing digits, press «+» to scroll up or «-» to scroll down.
- 4 Press «←» to confirm the selected step (no automatic acceptance).

**Note:** The allowed range for the step depends on the factor and the resolution of the balance. If it is outside the allowed range the error message "STEP OUT OF RANGE" will be displayed.

**Note:** If without any key press within 60 seconds, the balance returns to the previous active application. Press «C» to cancel and returns to the previous active application.

**On completion of the setting procedure, your balance is ready for division factor weighing.**

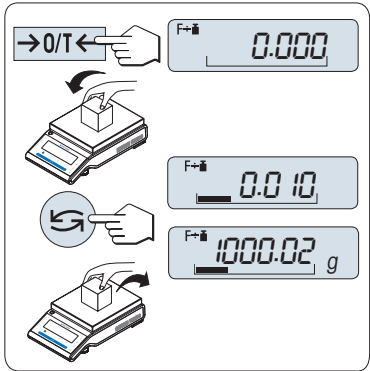

### Weighing procedure

- 1 Press « $\rightarrow 0/T \leftarrow$ » to zero/tare.
- 2 Load sample weight on weighing pan.
- 3 Read the result. The appropriate calculation is then made using the weight of sample and the selected factor, the result being displayed with the selected display step.  
**Note:** No units are displayed. To avoid a division by zero, the factor division is not calculated at zero.
- 4 Unload sample weight.

### toggling between displaying the calculated value and the measured weight:

You can use the « $\leftarrow$ » key to toggle between the calculated Value, weight value "UNIT 1", "RECALL" value (if selected) and weight value "UNIT 2" (if different from "UNIT 1").

### Terminate the application

Press and hold « $\Delta$ » to terminate the application and to return to the weighing application.

## 7.8 Application "Density"



The **"Density"** application allows you to determine the density of solid bodies and liquids. Determination of the density uses **Archimedes' principle** according to which a body immersed in a fluid undergoes an apparent loss in weight which is equal to the weight of the fluid it displaces.

To determine the density of solid bodies, we recommend you to work with the optional density kit which contains all the attachments and aids needed for convenient and precise density determination. To determine the density of liquids, you additionally need a sinker which you can also obtain from your METTLER TOLEDO dealer.

### Note for performing of density determinations:

- You can also use the hanger for weighing below the balance which belongs to your balance.
- We recommend you to consult the operating instructions enclosed with the density kit.
- If a METTLER TOLEDO printer is attached to your balance, the settings will be automatically recorded.

**Requirement:** The function **"DENSITY"** must be assigned to an «Fx» key (see advanced menu topic **"ASSIGN:Fx"**). Density kit is installed.



- Activate function **"DENSITY"** by pressing and holding the appropriate assigned «Fx» key.

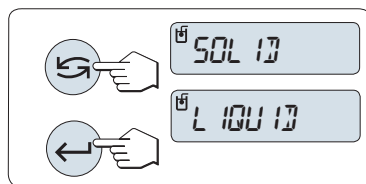

### Setting the method for density determination

- 1 Select:
  - "**SOLID**", the function for the density determination of solids, or
  - "**LIQUID**", the function for the density determination of liquids with a sinker.
- 2 Press «←» to confirm the selection

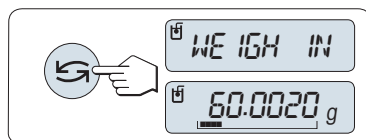

### Switching the display between user guidance and weighing

- Press «→» to toggle the display between user guidance and weighing.

### Terminate the application

Press and hold «ΔΔ» to terminate the application and to return to the weighing application.

### 7.8.1 Density Determination of Solids

**Requirement:** The method **"SOLID"** is set.

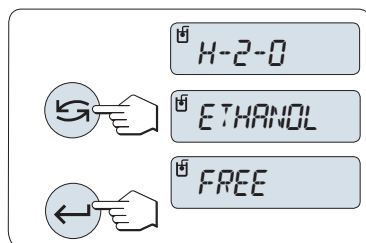

### Setting the parameter of the auxiliary liquid

- 1 Select the auxiliary liquid by scrolling with «↶» (or «-» up / «+» down):
  - "**H-2-O**" for distilled water, "**ETHANOL**" or "**FREE**" for a freely definable auxiliary liquid.
- 2 Press «←» to confirm the selection.

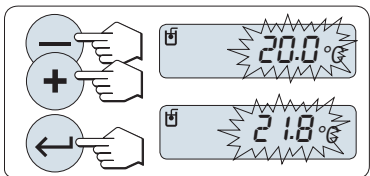

### If you have selected water or ethanol as the auxiliary liquid:

- 1 Enter the current temperature of the auxiliary liquid (read off on thermometer). Change the value by scrolling up «+» or down «-». The temperature ranges from 10 °C to 30.9 °C.
- 2 Press «←» to confirm the value.

**Note:** The densities of distilled water and ethanol in the range 10 °C to 30.9 °C are stored in the balance.

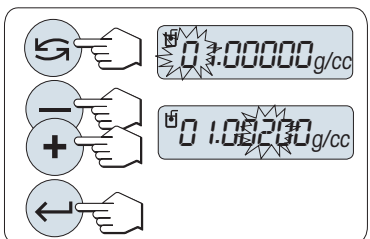

### If you have selected a freely definable auxiliary liquid:

Enter the density of the auxiliary liquid at the current temperature (read off on thermometer).

- 1 Press «C» to select a digit. The selected digit is blinking.
- 2 For changing digits, press «+» to scroll up or «-» to scroll down.
- 3 Press «←» to confirm the selected value.

**Note:** If without any key press within 60 seconds or by pressing «C», the balance returns to the previous active application.

**On completion of the settings, your balance is ready for performing the density determination of liquids.**

**Note:** Taring the balance is possible at any time.



The balance prompts you: **"PRESS ENTER TO START"**.

- Press «←» to start. Tare/Zero is executed.

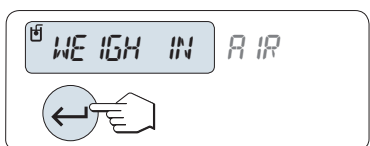

The balance prompts you to weigh the solid in air **"WEIGH IN AIR"**.

- 1 Load the solid.
- 2 Press «←» to initiate the measurement.

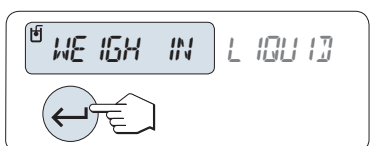

The balance prompts you to weigh the solid in the auxiliary liquid **"WEIGH IN LIQUID"**.

- 1 Load the solid.
- 2 Press «←» to initiate the measurement.

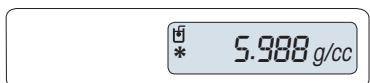

The balance now shows the determined density of the solid.

### Note:

- This result has already been corrected for the air buoyancy. The buoyancy caused by the two immersed wires (Ø 0.6 mm) can be neglected.
- By pressing «C», the balance returns to **"PRESS ENTER TO START"**.

### Result:

Press «», the result will be printed.

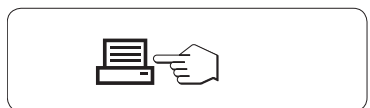



**Sample printout:**

```

---- Density Solid ----
18.Mar 2010          20:14
Balance Type       MS204S
SNR                1234567890
-----

ID:                .....

Liquid:
H-2-O             0.99822 g/cm3
Temp.             20.0 °C
Weight in air:
                  60.0020 g
Weight in liquid:
                  49.9997 g
Volume of solid:
                  1.625 cm3

Density:          5.988 g/cm3
                  =====

Signature
.....
-----
    
```

**7.8.2 Density Determination of Liquids**

**Requirement:** The method "LIQUID" is set.

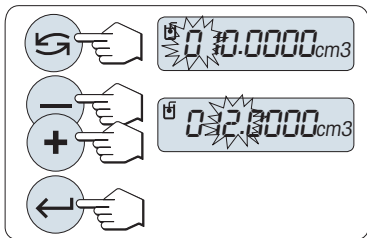

**Setting the displacement volume of your sinker**

Press «←» to confirm the default value of 10.0 cm<sup>3</sup> or change it if needed:

- 1 Press «↶» to select a digit. The selected digit is blinking.
- 2 For changing digits, press «+» to scroll up or «-» to scroll down
- 3 Press «←» to confirm the selected value.

**Note:** If without any key press within 60 seconds or by pressing «C», the balance returns to the previous active application.

**On completion of the settings, your balance is ready for performing the density determination of liquids.**

**Note:** Taring the balance is possible at any time.



The balance prompts you: "PRESS ENTER TO START".

- Press «←» to start.



The balance prompts you to weigh the sinker in air "WEIGH IN AIR".

- 1 Position the sinker.
- 2 Press «←» to initiate the measurement.



The balance prompts you to weigh the sinker in the liquid "**WEIGH IN LIQUID**".

- 1 Pour the liquid into the beaker. Make sure that the sinker is immersed by at least 1 cm in the liquid, and that there are no air bubbles in the container.
- 2 Press «←» to initiate the measurement.

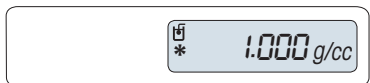

The balance now shows the determined density of the liquid at the current temperature (read off on the thermometer).

**Note:**

- This result has already been corrected for the air buoyancy. The buoyancy caused by the immersed wire (Ø 0.2 mm) of the sinker can be neglected.
- By pressing «C», the balance returns to "**PRESS ENTER TO START**".

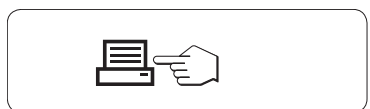

**Result:**

Press «», the result will be printed.

**Sample printout:**

```

----- Density Liquid -----
18.Mar 2010          20:14
Balance Type      MS204S
SNR              1234567890
-----

ID:      .....

Temp. of liquid:
          .....

Displaced liquid:
          10.0023 g

Density:    1.000 g/cm3
           =====

Signature
          .....
-----

```

**7.8.3 Formulae Used to Calculate Density**

The "**DENSITY**" Application is based on the formulae listed below.

**Formulae for determining the density of solids with compensation for air density**

$$\rho = \frac{A}{A-B} (\rho_0 - \rho_L) + \rho_L$$

$$V = \alpha \frac{A - B}{\rho_0 - \rho_L}$$

$\rho$  = Density of the sample

- A = Weight of the sample in air  
 B = Weight of the sample in the auxiliary liquid  
 V = Volume of the sample  
 $\rho_0$  = Density of the auxiliary liquid  
 $\rho_L$  = Density of Air (0.0012 g/cm<sup>3</sup>)  
 $\alpha$  = Weight correction factor (0.99985), to take the atmospheric buoyancy of the adjustment weight into account

**Formula for determining the density of liquids with compensation for air density**

$$\rho = \alpha \frac{P}{V} + \rho_L$$

- $\rho$  = Density of the liquid  
 P = Weight of the displaced liquid  
 V = Volume of the sinker  
 $\rho_L$  = Density of air (0.0012 g/cm<sup>3</sup>)  
 $\alpha$  = Weight correction factor (0.99985), to take the atmospheric buoyancy of the adjustment weight into account

**Density Table for Distilled Water**

T/°C	0.0	0.1	0.2	0.3	0.4	0.5	0.6	0.7	0.8	0.9
10.	0.99973	0.99972	0.99971	0.99970	0.99969	0.99968	0.99967	0.99966	0.99965	0.99964
11.	0.99963	0.99962	0.99961	0.99960	0.99959	0.99958	0.99957	0.99956	0.99955	0.99954
12.	0.99953	0.99951	0.99950	0.99949	0.99948	0.99947	0.99946	0.99944	0.99943	0.99942
13.	0.99941	0.99939	0.99938	0.99937	0.99935	0.99934	0.99933	0.99931	0.99930	0.99929
14.	0.99927	0.99926	0.99924	0.99923	0.99922	0.99920	0.99919	0.99917	0.99916	0.99914
15.	0.99913	0.99911	0.99910	0.99908	0.99907	0.99905	0.99904	0.99902	0.99900	0.99899
16.	0.99897	0.99896	0.99894	0.99892	0.99891	0.99889	0.99887	0.99885	0.99884	0.99882
17.	0.99880	0.99879	0.99877	0.99875	0.99873	0.99871	0.99870	0.99868	0.99866	0.99864
18.	0.99862	0.99860	0.99859	0.99857	0.99855	0.99853	0.99851	0.99849	0.99847	0.99845
19.	0.99843	0.99841	0.99839	0.99837	0.99835	0.99833	0.99831	0.99829	0.99827	0.99825
20.	0.99823	0.99821	0.99819	0.99817	0.99815	0.99813	0.99811	0.99808	0.99806	0.99804
21.	0.99802	0.99800	0.99798	0.99795	0.99793	0.99791	0.99789	0.99786	0.99784	0.99782
22.	0.99780	0.99777	0.99775	0.99773	0.99771	0.99768	0.99766	0.99764	0.99761	0.99759
23.	0.99756	0.99754	0.99752	0.99749	0.99747	0.99744	0.99742	0.99740	0.99737	0.99735
24.	0.99732	0.99730	0.99727	0.99725	0.99722	0.99720	0.99717	0.99715	0.99712	0.99710
25.	0.99707	0.99704	0.99702	0.99699	0.99697	0.99694	0.99691	0.99689	0.99686	0.99684
26.	0.99681	0.99678	0.99676	0.99673	0.99670	0.99668	0.99665	0.99662	0.99659	0.99657
27.	0.99654	0.99651	0.99648	0.99646	0.99643	0.99640	0.99637	0.99634	0.99632	0.99629
28.	0.99626	0.99623	0.99620	0.99617	0.99614	0.99612	0.99609	0.99606	0.99603	0.99600
29.	0.99597	0.99594	0.99591	0.99588	0.99585	0.99582	0.99579	0.99576	0.99573	0.99570
30.	0.99567	0.99564	0.99561	0.99558	0.99555	0.99552	0.99549	0.99546	0.99543	0.99540

### Density Table for Ethanol

T/°C	0.0	0.1	0.2	0.3	0.4	0.5	0.6	0.7	0.8	0.9
10.	0.79784	0.79775	0.79767	0.79758	0.79750	0.79741	0.79733	0.79725	0.79716	0.79708
11.	0.79699	0.79691	0.79682	0.79674	0.79665	0.79657	0.79648	0.79640	0.79631	0.79623
12.	0.79614	0.79606	0.79598	0.79589	0.79581	0.79572	0.79564	0.79555	0.79547	0.79538
13.	0.79530	0.79521	0.79513	0.79504	0.79496	0.79487	0.79479	0.79470	0.79462	0.79453
14.	0.79445	0.79436	0.79428	0.79419	0.79411	0.79402	0.79394	0.79385	0.79377	0.79368
15.	0.79360	0.79352	0.79343	0.79335	0.79326	0.79318	0.79309	0.79301	0.79292	0.79284
16.	0.79275	0.79267	0.79258	0.79250	0.79241	0.79232	0.79224	0.79215	0.79207	0.79198
17.	0.79190	0.79181	0.79173	0.79164	0.79156	0.79147	0.79139	0.79130	0.79122	0.79113
18.	0.79105	0.79096	0.79088	0.79079	0.79071	0.79062	0.79054	0.79045	0.79037	0.79028
19.	0.79020	0.79011	0.79002	0.78994	0.78985	0.78977	0.78968	0.78960	0.78951	0.78943
20.	0.78934	0.78926	0.78917	0.78909	0.78900	0.78892	0.78883	0.78874	0.78866	0.78857
21.	0.78849	0.78840	0.78832	0.78823	0.78815	0.78806	0.78797	0.78789	0.78780	0.78772
22.	0.78763	0.78755	0.78746	0.78738	0.78729	0.78720	0.78712	0.78703	0.78695	0.78686
23.	0.78678	0.78669	0.78660	0.78652	0.78643	0.78635	0.78626	0.78618	0.78609	0.78600
24.	0.78592	0.78583	0.78575	0.78566	0.78558	0.78549	0.78540	0.78532	0.78523	0.78515
25.	0.78506	0.78497	0.78489	0.78480	0.78472	0.78463	0.78454	0.78446	0.78437	0.78429
26.	0.78420	0.78411	0.78403	0.78394	0.78386	0.78377	0.78368	0.78360	0.78351	0.78343
27.	0.78334	0.78325	0.78317	0.78308	0.78299	0.78291	0.78282	0.78274	0.78265	0.78256
28.	0.78248	0.78239	0.78230	0.78222	0.78213	0.78205	0.78196	0.78187	0.78179	0.78170
29.	0.78161	0.78153	0.78144	0.78136	0.78127	0.78118	0.78110	0.78101	0.78092	0.78084
30.	0.78075	0.78066	0.78058	0.78049	0.78040	0.78032	0.78023	0.78014	0.78006	0.77997

Density of C<sub>2</sub>H<sub>5</sub>OH according to the "American Institute of Physics Handbook".

## 7.9 Application "PipetteCheck"

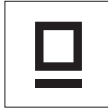

The "PipetteCheck" application allows you to check the volume of pipettes from any manufacturer, with the gravimetric method. For checking pipettes we recommend using the METTLER TOLEDO Evaporation Trap for NewClassic Balances. This Evaporation Trap minimizes moisture evaporation for more accurate results, see Accessories (page 90).

Maximum 3 different test volumes are possible for checking the pipette. The test volumes recommended by the manufacturer are usually 10%, 50%, and 100% of the nominal volume of the pipette. The liquid to determine the volume of the pipette is water and the following conditions must be known:

- Current temperature of the test liquid
- Current barometric air pressure of the test environment
- Current relative humidity of the test environment

Based on the test results on the printout of the statistic and your specifications, you can decide whether the pipette can be used for further applications (successfully or failed).

### Requirement:

- A printer must be connected.
- The Evaporation Trap is ready installed (recommended).
- The function "PIPETTE" must be assigned to an «Fx» key (see advanced menu topic "ASSIGN:Fx").



- Activate function "PIPETTE" by pressing and holding the appropriate assigned «Fx» key.

### Setup

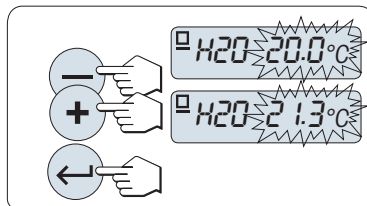

#### Setting the test liquid temperature:

- The setting range is 15.0 °C up to 30.0 °C.
- 1 Press «+» to scroll up or press «-» to scroll down to set the liquid temperature.
  - 2 Press «←» to confirm the setting (no automatic acceptance).

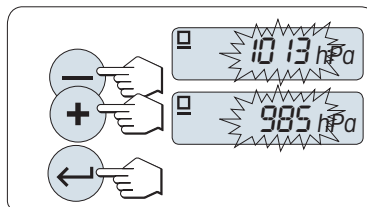

#### Setting the barometric air pressure of the test environment:

The setting range is 850 hPa up to 1090 hPa.

- 1 Press «+» to scroll up or press «-» to scroll down to set the barometric air pressure.
- 2 Press «←» to confirm the setting (no automatic acceptance).

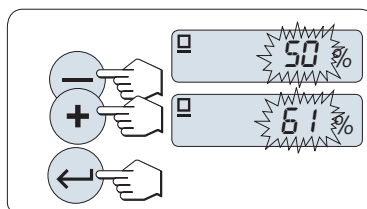

#### Setting the relative humidity of the test environment:

The setting range is 20 % up to 90 %.

- 1 Press «+» to scroll up or press «-» to scroll down to set the relative humidity.
- 2 Press «←» to confirm the setting (no automatic acceptance).

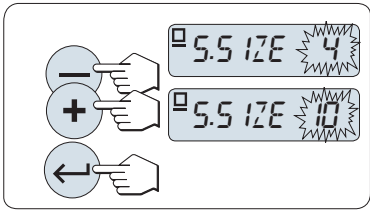

### Setting the sample size.

Set how many measurements should be performed for the selected test volume before the measurement cycle is complete. The setting range is from 4 up to 10.

- 1 Select the sample size.
- 2 Press «←» to toggle between the values 4 to 10.
- 3 Press «←» to confirm the selection (no automatic acceptance).

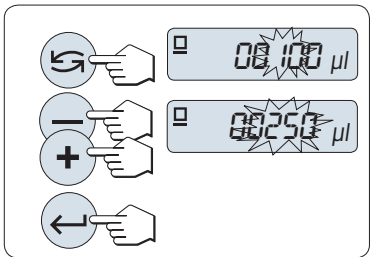

### Setting the test volume

The setting range is 1 µl up to 20000 µl.

- 1 Press «←» to select a digit. The selected digit is blinking.
- 2 For changing digits, press «+» to scroll up or «-» to scroll down.
- 3 Press «←» to confirm the setting and to start the pipette check. Application header and settings are printed.

**Note:** If without any key press within 60 seconds, the balance returns to the previous active application. Press «C» to cancel and returns to the previous active application.

### Pipette Check Start

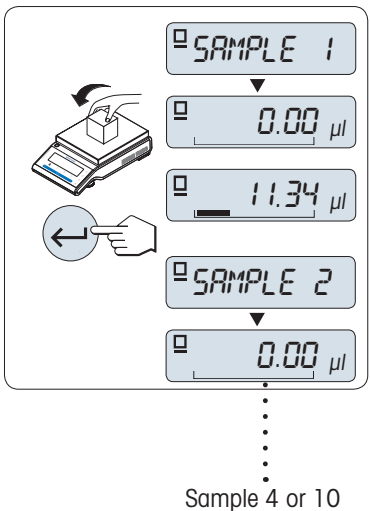

- ▶ **Sample 1** appears briefly on the display (Sample counter).
  - ▶ The balance shows zero.
- 1 Weigh the first sample.
  - 2 Press «←» to confirm the weighing.
    - ⇒ The weight of sample 1 is stored and printed.
  - 3 Weigh next samples with the same procedure as for the first sample, until the defined number of samples is reached.
    - ⇒ The statistics is printed and shown on the display.
  - 4 Press «C» to continue the pipette check or Press «←» (several times) to show all statistic values on the display first.

Displayed results:

0.5 seconds

systematic error, absolute	☐ SYS.ERR <sub>abs</sub> ▶ *☐ 1.24 µl ←
systematic error, relative	☐ SYS.ERR <sub>rel</sub> ▶ *☐ 10.91% ←
random error, absolute	☐ RAND.ERR <sub>abs</sub> ▶ *☐ 0.13 µl ←
random error, relative	☐ RAND.ERR <sub>rel</sub> ▶ *☐ 1.32% ←

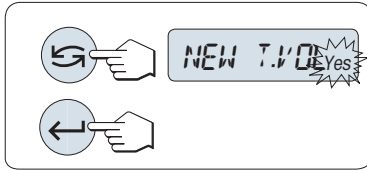

### Pipette check continue

- Continue the check with another test volume. Three different test volumes are possible. After three test volume, the balance terminates the check of the pipette automatically.
- Terminate pipette check.

▶ "NEW T.VOL" appears on the display.

- 1 Select "YES" to continue or select "NO" to terminate the check of the pipette.
- 2 Press «↔» to toggle between "YES" or "NO".
- 3 Press «←» to confirm the selection.

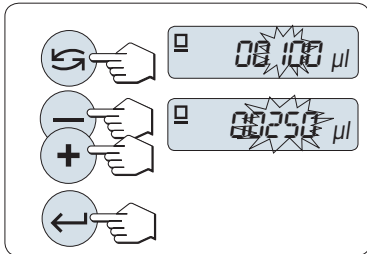

### Continue pipette check

- 1 Set the next test volume.
- 2 Press «↔» to select a digit. The selected digit is blinking.
- 3 For changing digits, press «+» to scroll up or «-» to scroll down.
- 4 Press «←» to confirm the setting and to start the pipette check. The sample header with the new test volume is printed.
- 5 To continue, refer to "Pipette Check Start" in this instructions. Same procedure for further test volume.

### Terminate pipette check

The printout will be completed and the balance returns to the weighing application.

**Sample printout, shown with one test volume**

```
---- Pipette Check ----
05.Jan 2012          12:56

METTLER TOLEDO

Balance Type      MS204
SNR              1234567890
-----
Pipette SNR:

.....
Pipette Nominal:

.....

Liquid:
H-2-O           0.99820 g/cm3
Temp            20.0 °C
Air:
Pressure        1013 hPa
Relative humidity 50 %
Correction factor Z:
                1.00285 µl/mg
Sample size     4

Test volume     100.00 µl
Sample measurements
1              100.36 µl
2              99.81 µl
3              101.03 µl
4              100.92 µl

x              100.53 µl
Systematic error:
e abs          1.24 µl
e rel          10.91 %
Random error:
s dev          0.13 µl
s rel          1.32 %

Test PASSED/FAILED

Signature:

.....
-----
```



## 7.10 Application "Routine Test"



The "**Routine Test**" application allows you to determine the sensitivity of the balance. More about periodic sensitivity tests (routine tests) see: **GWP**<sup>®</sup> (Good Weighing Practice) on [www.mt.com/gwp](http://www.mt.com/gwp).

GWP gives clear recommendation for routine testing:

- how should I test my balance?
- how often?
- where can I reduce efforts?

More about test weights see [www.mt.com/weights](http://www.mt.com/weights).

### Requirement:

- The function "**R. TEST**" must be assigned to «**F3**» key (see advanced menu topic "**ASSIGN:F3**").
- It is recommended to connect a printer or a PC to the balance for showing the results.

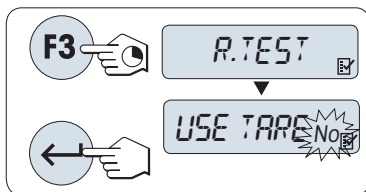

- 1 Activate function "**R. TEST**" by pressing and holding the assigned «**F3**» key.
- 2 Select "No" (no tare weight used).  
If a tare weight is used during the test select "Yes" (use a tare weight). To toggle between "Yes" and "No" use «**↔**» (or «**+**» or «**-**»).
- 3 Press «**←**» to confirm the selection.

### Note:

- It is recommended to test the sensitivity without tare load. (factory setting "No").
- If using tare: Make sure that tare weight plus test weight is not exceeding max. load.

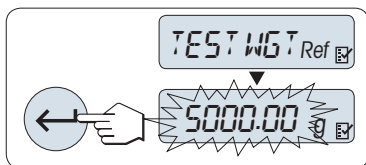

### Setting the reference test weight value

The default value of the test weight: Next smaller OIML weight than the maximum load of your balance according to the GWP<sup>®</sup> recommendation.

- 1 For changing the value, press «**+**» to scroll up or «**-**» to scroll down. Progressing speed by press and hold.
- 2 Press «**←**» to confirm the value.

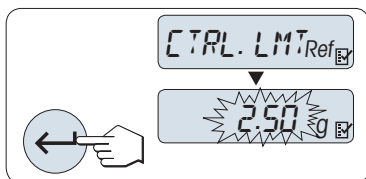

### Setting the Control Limit

The default value of the control limit:

Test weight x weighing process tolerance / 2

Example: 5000 g x 0.1% / 2 = 2.50 g.

- 1 For changing the value, press «**+**» to scroll up or «**-**» to scroll down. Progressing speed by press and hold.
- 2 Press «**←**» to confirm the value.

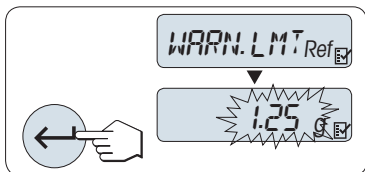

### Setting the Warning Limit

The default value of the warning limit:  
 Warning limit = control limit / safety factor  
 Example: 2.5 g / 2 = 1.25 g.

- 1 For changing the value, press «+» to scroll up or «-» to scroll down. Progressing speed by press and hold.
- 2 Press «←» to confirm the value.

**Note:** The default values of control limit and the warning limit are evaluated according the GWP recommendation. These are based under the assumption that the weighing process tolerance is 0.1% and the safety factor is 2.

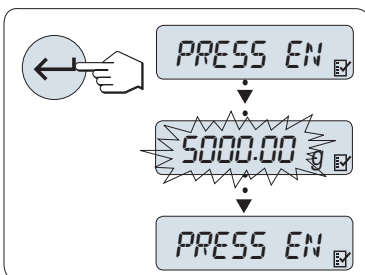

### On completion of the setting procedure, your balance is ready for the routine test procedure.

**Note:** The test weight must be acclimatized to the ambient temperature of the balance.

- 1 Press «←» to start the test.
- 2 Follow the instructions on the display. If the test weight value is flashing: Load the test weight (displayed value).

The printout starts after the weighing pan is unloaded.

### Exit the current test procedure:

- Press and hold « $\Delta$ », «F1», «F2» for executing a new application.

### Printout:

```

----- Routine Test -----
21.Jan 2009      12:56

METTLER TOLEDO

Balance Type  MS6002S/01
SNR           1234567890

Sensitivity:
Test weight   5000.00 g
Value         5000.11 g
Warning L.    1.25 g
Control L.    2.50 g
Warning L.    OK
Control L.    OK

Signature

.....
-----
  
```

### What if Warning Limit or Control Limit are "FAILED"?

The "SOP for Periodic Sensitivity Tests (Routine Tests)" provides information about measures when routine tests fail. Find a download version of these SOPs on [www.mt.com/gwp](http://www.mt.com/gwp), link "GWP® The Program / Routine Operation".

### Content of SOP:

- Preparation
- Test procedure

- Evaluation
- Deviation
  - If Warning Limit "**FAILED**"
  - If Control Limit "**FAILED**"

## 7.11 Application "Diagnostics"



The "**Diagnostics**" application allows you to carry out predefined diagnostics tests and to view or print predefined sets of balance information. This diagnostics tool helps you find errors faster and more efficiently.

**Requirement:** A printer or a PC is connected to the balance for showing the results.

- 1 Activate "**ADVANCED**" menu. (See section menu operation)
- 2 Activate function "**DIAGNOSE**" by pressing «←|».
- 3 Use «↻» to select appropriate tests.

### 7.11.1 Repeatability Test

The repeatability test allows you to repeat tests with internal weight for a given number of times.

**Note:** On models with internal weights only.

- 1 Press «←|» to activate repeatability test "**REPEAT.T**". "**R. TST. 10**" appears on the Display.
- 2 Enter the number of times (blinking) by pressing «+» or «-». Possible values are 5, 10 (default), 20, 50, 100 times.
- 3 Press «←|» to start the test. The message "**RUNNING REPEAT TEST**" is displayed till the tests are completed.
- 4 Press «≡» to print the test information..
- 5 Press «←|» to scroll forward through the displayed list.
- 6 Press «C» to cancel the test procedure. The balance will return to the topic "**DIAGNOSE**".

**Sample Information Displayed:**

Displayed for 0.5 s	Display
"S DEV"	* 0.004 g
"MAX. TEMP"	21.2 °C
"MIN. TEMP"	21.0 °C
"MEAN. TEMP"	21.1 °C
"TOT.TIME"	00:01:26

## Sample Printout:

```
-- Repeatability Test --
21.Jan 2009      11:34

METTLER TOLEDO

Balance Type  MS6002S/01
SNR           1234567890
SW            V1.00
Temperature   21.3 °C
No. of tests  10
-----
1. Time       00:00:00
1. Temp.     21.3 °C
2. Time       00:00:04
2. Temp.     21.3 °C
.
.
.
-----
s Dev.       0.004 g
Max Temp.    21.2 °C
Min Temp.    21.0 °C
Mean Temp.   21.1 °C
Total Time   00:00:44
-----
```



### Examples:

Repeatability test is a tool to do functional check with the balance. It may be performed:

- **To check function of balance**
  - during installation to store print out with installation documents.
  - after preventative maintenance to store print out with installation maintenance report.
  - when remarkable decrease of weighing performance occurs, so that you can email/fax print out to service support provider for diagnose purposes.
- **To develop the optimal environment settings** (see menu topic "ENVIRON.").  
Measure the time you need to perform repeatability test with each "**STABLE**", "**STANDARD**" and "**UNSTABLE**" setting. The setting with the fastest total time suits best for the existing environmental conditions.

### 7.11.2 Display Test

The display test allows you to test the display of the balance.

- 1 Press «» to start "**DISPLAY**".  
All possible segments and icons on the display will illuminate.
- 2 Press «» to print the test information.
- 3 Press «**C**» to cancel the test procedure. The balance will return to the topic "**DIAGNOSE**".

### Sample Printout:





```
----- Display Test -----  
21.Jan 2009      11:34  
  
METTLER TOLEDO  
  
Balance Type      MS204S  
SNR               1234567890  
SW                V1.00  
Display Test      DONE  
-----
```

### 7.11.3 Key Test

The key test allows you to test the keys of the balance.

- 1 Press «←|» to start "**KEYPAD T**".
- 2 The message "**KEY TEST - PRESS KEY TO BE TESTED**" is displayed scrolling during the duration of the key test. Press every Key briefly. Each press of a key beeps and echoes with "**OK**" on the display.
- 3 Second press «C» key to print the test information. The test procedure will be cancelled and the balance will return to the topic "**DIAGNOSE**". If a key has not been tested before printing, then the test results will be indicated with a "----" line.

#### Sample Information Displayed:

Key	Display
«  »	1/10 D OK
«  »	<b>MENU OK</b>
«  »	<b>CAL OK</b>
«  »	<b>PRINT OK</b>
«-»	<b>MINUS OK</b>
«+»	<b>PLUS OK</b>
«  »	<b>TOGGLE OK</b>
«← »	<b>ENTER OK</b>
«C»	C OK
«→0/T←»	O/T OK

### Sample Printout:

```
----- Key Test -----
21.Jan 2009          11:34



METTLER TOLEDO

Balance Type      MS204S
SNR              1234567890
SW              V1.00
1/10 d Key      OK
Menu Key        OK
Cal Key         OK
Print Key       OK
Minus Key       OK
Plus Key        OK
Toggle Key      OK
Enter Key       OK
Zero/Tare Key   OK
Cancel Key      OK
-----
```

#### 7.11.4 Motor Test

The motor test allows you to test the calibration motor of the balance.

**Note:** On models with internal weight only.

- 1 Press «» to start "**CAL.MOT. T**".  
"**RUNNING**" is displayed during the Motor Test. A motor test is deemed successful when all the motor positions have been successfully tested. At the end of the test, the test information will be printed.
- 2 Press «» for printout.
- 3 Press «**C**» to cancel the test procedure. The balance will return to the topic "**DIAGNOSE**".

### Sample Printout:



```
----- Motor Test -----
21.Jan 2009          11:34

METTLER TOLEDO

Balance Type      MS204S
SNR              1234567890
SW              V1.00
Motor Test      OK
-----
```

#### 7.11.5 Balance History

The balance history function allows you to view and print the history of the balance.

- 1 Press «» to start "**BAL.HIST**".
- 2 Press «» for printout.
- 3 Press «» to scroll forward through the displayed list of balance history information.
- 4 Press «**C**» to cancel the test procedure. The balance will return to the topic "**DIAGNOSE**".

**Sample Information Displayed:**

Information	Display
Operation Time (year:day:hour)	00:018:04
Total load kg	115.7191 kg
Number of weighings	1255
Number of key pressed	4931
Number of motor movements	1012
Backlight time (year:day:hour)	00:018:04
Next service due date	01:01:2010

**Sample Printout:**

```

--- Statistical Info ---
21.Jan 2009      11:34

METTLER TOLEDO

Balance Type      MS4002S
SNR               1234567890
SW               V1.00
-----
Operating time
                  18d 4h
Total weight loaded
                  115.7191 kg
Number of weighings
                  1255
Number of key presses
                  4931
Motor movements
                  1012
Backlight operating time
                  18d 4h
Next service due date
                  01.01.2010
-----

```

### 7.11.6 Calibration History

The "Calibration History" function allows you to view and print information of the last 30 (thirty) balance adjustment. Adjustments made by a service technician and normal user are counted together.

- 1 Press «←|» to start "**CAL.HIST**".
- 2 Press «» for printout.
- 3 Press «←|» key to scroll forward through the displayed list of Adjustments history information.
- 4 Press «C» to cancel the test procedure. The balance will return to the topic "**DIAGNOSE**".

**Sample Information Displayed:**

Note	Display	
S = External adjusted service	05:03:09S	01
	-3 PPM	
F = FACT	05:03:09F	02
	2 PPM	



Note	Display	
	.	.
	.	.
	.	.
I = Internal adjusted	04:03:09I	28
	-1 PPM	
E = External adjusted user	03:03:09E	29
	4 PPM	
F = FACT	02:03:09F	30
	1 PPM	

### Sample Printout:

```

----- Calibration -----
05.Mar 2009      11:34

METTLER TOLEDO

Balance Type      MS204S
SNR               1234567890
SW                1.50
-----

01 05.Mar 2009   11:34
External ADJ SERVICE
                  23.5°C
Diff              -3ppm
-----

02 05.Mar 2009   09:00
FACT
                  22.4°C
Diff              2ppm
-----

.
.
.
28 03.Mar 2009   10:59
Internal ADJ USER
                  22.6°C
Diff              -1ppm
-----

29 02.Mar 2009   16:34
External ADJ USER
                  24.6°C
Diff              4ppm
-----

30 02.Mar 2009   18:36
FACT
                  22.4°C
Diff              1ppm
-----

```

### 7.11.7 Balance Information

The balance information function allows you to view and print information about your balance.

- 1 Press «←|» to start "BAL.INFO".
- 2 Press «» for printout.
- 3 Press «←|» to scroll forward through the displayed list of Balance information.

4 Press «C» to cancel the test procedure. The balance will return to the topic "**DIAGNOSE**".

**Sample information displayed:**

Information	Display
Balance type	<b>TYPE</b> MS6002S
Max. load	<b>MAX</b> 6200 g
Software platform	<b>PLATFORM</b> RAINBOW
Serial number	SNR 1234567890
Type definition number	TDNR 9.6.3.411
Software version	<b>SOFTWARE</b> V1.00
Cell ID	<b>CELL ID</b> 1172400044
Cell type	<b>CELL TYPE</b> MMAI6000G2
Tolerance revision number	<b>TOLERANCE</b> NO2
Language	<b>LANGUAGE</b> ENGLISH

**Sample Printout:**

```
-- Balance Information -
05.Mar 2009      11:34

METTLER TOLEDO

Balance Type      MS6002S
SNR               1234567890
SW                V1.00
Max              6200 g
Platform         Rainbow
TDNR             9.6.3.411.2-03
Cell ID          1172400044
Cell Type        MMAI6000G2
Tolerance Rev. no.  2
Language         English
-----
```

### 7.11.8 Service Provider Information

The service provider Information function allows you to print information about your service provider.

- 1 Press «←» to start "**PROVIDER**". The service provider information will be displayed.
- 2 Press «». The service provider information will be printed and the balance will return to the topic "**DIAGNOSE**".

**Sample Printout:**

```
--- Service Provider ---
21.Jan 2009      11:34

METTLER TOLEDO
Im Langacher
CH-8606 Greifensee
Switzerland
(+41) 044 944 22 11
-----
```

## 8 Communication with Peripheral Devices

### 8.1 Function PC-Direct

The numerical value displayed at the balance can be transferred to the cursor position in Windows Applications (e.g. Excel, Word) as by typing with the keyboard.

**Note:** The units will not be transferred.

#### Requirements

- PC with one of the Microsoft Windows® operating system 32bit/64bit: XP (SP3), Vista (SP2), Win 7 (SP1) or Win 8.
- Serial interface RS232 or USB.
- Administrator rights for installing software (for USB not required).
- Windows Application (e.g. Excel).
- Balance to PC connection with cable RS232 or USB.

#### Settings at the balance:

##### Attention

- DISCONNECT THE USB CONNECTION FROM THE BALANCE PRIOR TO CHANGE THE SETTINGS.
- USB does not work with keyboards where the "Shift" key must be pressed for entering numbers.

Balance Interface Settings (see Interface Menu):

- Topic "**RS232**" or "**USB**": set "**PC-DIR.**" and select the most appropriate option for the desired weighing result.
- Topic "**RS.TX.E.O.L.**"/"**RS E.O.L.**" or "**USB E.O.L.**"/"**USB E.O.L.**":
  - set **<TAB>** to write into the same row (e.g. in Excel).
  - set **<CR><LF>** to write into the same column (e.g. in Excel).
- Save changes.

#### Settings at the PC:

##### Installing SerialPortToKeyboard

Operation of PC-Direct via serial port RS232 requires the installation of **SerialPortToKeyboard** on your host computer.

##### Using CD-ROM

- 1 Insert the product CD in the CD/DVD drive of the host computer.
- 2 Double click the folder **SerialPortToKeyboard**.

##### Using internet

- 1 Go to the site <http://www.mettler-toledo-support.com>.
- 2 Log in to the METTLER TOLEDO Balance Support Site (registration with the serial number of a METTLER TOLEDO instrument required).
- 3 Click **Customer Support**
- 4 Click appropriate product folder and save the program file **SerialPortToKeyboard.exe** on your specified storage location.

##### Installing procedure

- 1 Right-click on **SerialPortToKeyboard.exe** and select **Run as Administrator** from the menu.
- 2 Follow the installer's instructions.

### Settings for SerialPortToKeyboard

- 1 Select the serial port (COM) to be used for connection with the balance.
- 2 Set the baud rate to 9600.
- 3 Activate "Connect"

#### Note

- The window can be minimized.
- Closing of the window terminates the session.

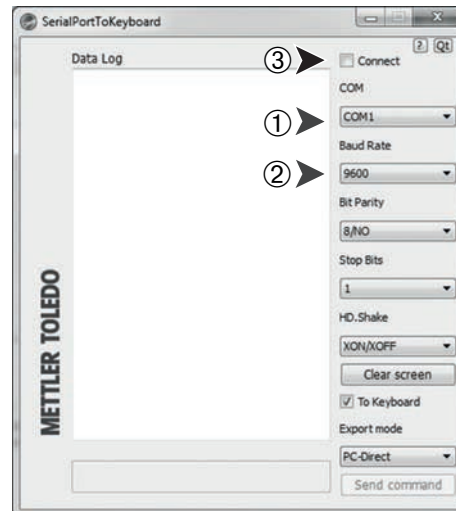

### Checking Operation

- 1 Start **SerialPortToKeyboard** (RS232)
- 2 Start Excel (or another application) at the PC.
- 3 Activate a cell in Excel.

According to your selected "**PC-DIR.**" option, the displayed values will appear e.g. in the column one after the other one in the different rows.

## 8.2 USB Device Interface

To perform the functionality "**HOST**" with a PC equipped only with a USB Interface, you have to assign an appropriate USB Driver on the PC first.

### Requirements

- Balance with USB Device Interface.
- PC with one of the Microsoft Windows® operating system 32bit/64bit: XP (SP3), Vista (SP2), Win 7 (SP1) or Win 8.
- Administrator rights for installing software.
- PC to balance USB connection cable.

### Installing USB Driver on the PC:

#### Using CD-ROM

- 1 Insert the product CD in the CD/DVD drive of the host computer.
- 2 Double click the folder **USB Driver**.
- 3 Click **USBDriverInstaller.exe**.

#### Using internet

- 1 Connect to the Internet
- 2 Go to the site <http://www.mettler-toledo-support.com>.
- 3 Log in to the METTLER TOLEDO Balance Support Site (registration with the serial number of a METTLER TOLEDO instrument required).
- 4 Click **Customer Support**.
- 5 Click appropriate product folder.
- 6 Click **USB Driver**.

- 7 Click **USBDriverInstaller.exe**.

### Installing procedure

- 1 Click **Save** to download to your specified location.
- 2 Right-click on the downloaded install program: **USBDriverInstaller.exe** and select **Run as Administrator** from the menu.
- 3 If a safety warning appears, allow Windows to install.

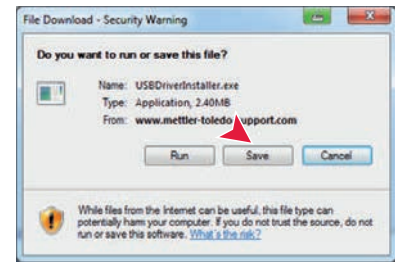

- 4 Click **Next** and follow the installer's instructions.

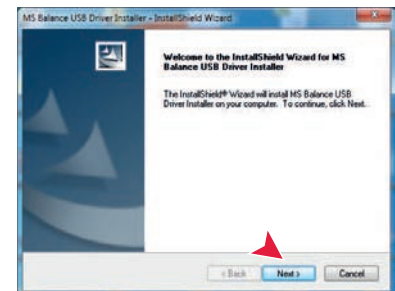

### Installing Instrument

- 1 Switch the balance **off**.
- 2 Connect the balance to the preferred USB Port on the PC.
- 3 Switch the balance **on**.
- 4 Follow the instructions of the Wizard and install the software automatically (recommended)

**Note:** The wizard appears again for each USB port, either on your PC or if another balance is connected.

**Warning:** Do not click **Cancel** as for the connected USB port, it might not be possible anymore to perform the installation process.



## 9 Firmware (Software) Updates

METTLER TOLEDO is continuously improving its balance firmware (software) for the benefit of customers, so that the customer can benefit quickly and easily from further developments, METTLER TOLEDO makes the latest firmware versions available on the Internet. The firmware made available on the Internet has been developed and tested by Mettler-Toledo AG using processes that meet the guidelines of ISO 9001. Mettler-Toledo AG does not, however, accept liability for consequences that might arise from using the firmware.

### 9.1 Operating Principle

You will find all the relevant information and updates for your balance on the METTLER TOLEDO website at the following address:

**[www.mettler-toledo-support.com](http://www.mettler-toledo-support.com)**

A program known as the "**e-Loader II**" is loaded onto your computer together with the firmware update. You can use this program to download the firmware to the balance. The "e-Loader II" can also save the settings in your balance before the new firmware is downloaded to it. You can reload the saved settings into the balance manually or automatically after the software is downloaded.

If the selected update includes an application that is not described in these instructions (or that has been updated in the meantime) you can download the corresponding instructions in Adobe Acrobat® PDF format.

#### Note

New applications might not be visible unless the type data are updated by a service technician.

#### Requirements

The minimum requirements for obtaining applications from the Internet and downloading them into your balance are as follows:

- PC with one of the following Microsoft Windows® operating system:
  - Microsoft® Windows® XP Home or Professional with Service Pack 3 (32 bit)
  - Microsoft® Windows Vista® Home Premium, Business, Ultimate, or Enterprise with Service Pack 2 (32 bit and 64 bit)
  - Microsoft® Windows 7 with Service Pack 1 Home Premium, Professional, Ultimate, or Enterprise (32 bit and 64 bit)
- Administrator rights for installing software.
- PC to balance connection cable (e.g. No. 11101051 see chapter accessories)

### 9.2 Update Procedure

#### Installing the "e-Loader II" software from the Internet onto the PC.

- 1 Connect to the Internet.
- 2 Go to the site <http://www.mettler-toledo-support.com>.
- 3 Log in to the **METTLER TOLEDO Balance Support Site** (registration with the serial number of a METTLER TOLEDO instrument required).
- 4 Click **Customer Support**.
- 5 Click appropriate product folder.
- 6 Click the firmware version (e-Loader II) you need and save it on your specified storage location.
- 7 Right-click on the **firmware SNxxx.exe** and select **Run as Administrator** from the menu.
- 8 Follow the installer's instructions.



**Loading the new firmware into the balance.**

- 1 Right-click on **METTLER TOLEDO e-Loader II** and select Run as Administrator from the menu.
- 2 Follow the instructions, which will take you step-by-step through the installation.

## 10 Error and Status Messages

### 10.1 Error Messages

Error messages in the display draw your attention to incorrect operation or that the balance could not execute a procedure properly.

Error Message	Cause	Rectification
<b>NO STABILITY</b>	No stability.	Ensure more stable ambient conditions. If not possible, check settings for environment.
<b>WRONG ADJUSTMENT WEIGHT</b>	Wrong adjustment weight on pan or none at all.	Place required adjustment weight in center of pan.
<b>REFERENCE TOO SMALL</b>	Reference for piece counting too small.	Increase reference weight.
<b>EEPROM ERROR - PLEASE CONTACT CUSTOMER SERVICE</b>	EEPROM (memory) error.	Please contact METTLER TOLEDO customer service.
<b>WRONG CELL DATA - PLEASE CONTACT CUSTOMER SERVICE</b>	Wrong cell data.	Please contact METTLER TOLEDO customer service.
<b>NO STANDARD ADJUSTMENT - PLEASE CONTACT CUSTOMER SERVICE</b>	No standard calibration.	Please contact METTLER TOLEDO customer service.
<b>PROGRAM MEMORY DEFECT - PLEASE CONTACT CUSTOMER SERVICE</b>	Program memory defect.	Please contact METTLER TOLEDO customer service.
<b>TEMP SENSOR DEFECT - PLEASE CONTACT CUSTOMER SERVICE</b>	Temperature sensor defect.	Please contact METTLER TOLEDO customer service.
<b>WRONG LOAD CELL BRAND - PLEASE CONTACT CUSTOMER SERVICE</b>	Wrong load cell brand.	Please contact METTLER TOLEDO customer service.
<b>WRONG TYPE DATA SET - PLEASE CONTACT CUSTOMER SERVICE</b>	Wrong type data set.	Please contact METTLER TOLEDO customer service.
<b>BATTERY BACKUP LOST - CHECK DATE TIME SETTINGS</b>	Backup battery is empty. This battery ensures that the date and time are not lost when the balance is disconnected from power.	Battery must be replaced. Please contact METTLER TOLEDO customer service.
	Overload - The weight on the pan exceeds the weighing capacity of the balance.	Reduce the weight on the weighing pan.
	Underload	Check that the weighing pan is positioned correctly.
<b>INITIAL ZERO RANGE EXCEEDED</b>	Wrong weighing pan or pan is not empty.	Mount correct weighing pan or unload weighing pan.
<b>BELOW INITIAL ZERO RANGE</b>	Wrong weighing pan or pan is missing.	Mount correct weighing pan.
<b>MEM FULL</b>	Memory full.	Clear the memory and start a new evaluation.
<b>FACTOR OUT OF RANGE</b>	Factor is outside the allow range.	Select a new factor.
<b>STEP OUT OF RANGE</b>	Step is outside the allow range.	Select a new step.
<b>OUT OF RANGE</b>	Sample weight is outside the allow range.	Unload the pan and load a new sample weight.



## 10.2 Status Messages

Status messages are displayed by means of small icons. The status icons indicate the following:

Status Icon	Signification
	<b>Service Reminder</b> Your balance is due for servicing. Contact your dealer's customer service department as soon as possible to have a technician service your balance. (See menu topic " <b>SERV.ICON</b> ")

## 11 Cleaning and Service

Every now and then, clean the weighing pan, draft shield element, bottom plate, draft shield (depending on the model) and housing of your balance. Your balance is made from high-quality, durable materials and can therefore be cleaned using a damp cloth or with a standard cleaning agent.

To thoroughly clean the draft shield glass panels, remove the draft shield from the balance. When reinstalling the draft shield, ensure that it is in the correct position.

### Please observe the following notes:



- The balance must be disconnected from the power supply
- Ensure that no liquid comes into contact with the balance or the AC adapter.
- Never open the balance or AC adapter – they contain no components, which can be cleaned, repaired or replaced by the user.
- Use only the power cable from METTLER TOLEDO, if it needs replacing.



- On no account use cleaning agents which contain solvents or abrasive ingredients, as this can result in damage to the operation panel overlay.

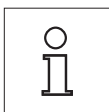

Please contact your METTLER TOLEDO dealer for details of the available service options. Regular servicing by an authorized service engineer ensures constant accuracy for years to come and prolongs the service life of your balance.

### 11.1 Cleaning the Glass Draft Shield

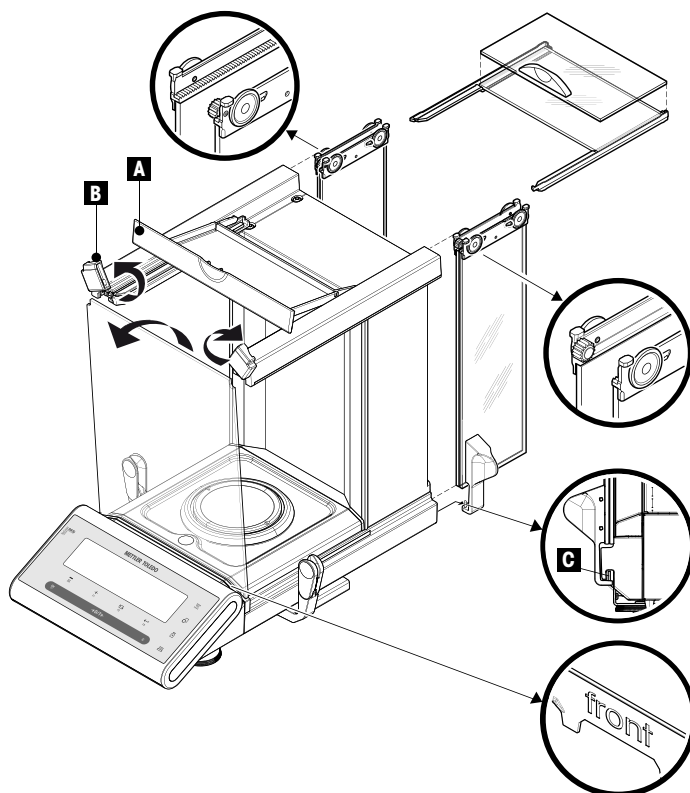

#### Important note

**Removing and inserting the side door glass panels and top door glass panels:** Always hold the 2 parallel guided glass panels **together and parallel with one hand** (see illustrations).

- 1 Push all the glass panels as far as they will go to the back.
- 2 Turn the top cover (A) to the front.
- 3 Pull the side door glass panels and the top door glass panels towards the back and off. (observe the important note above)
- 4 Turn the two lock covers (B) on the front as far as they will go to unlock the front glass.
- 5 Tilt the front glass forward and pull it out.
- 6 Remove draft ring.
- 7 Remove weighing pan.
- 8 Remove drip tray.

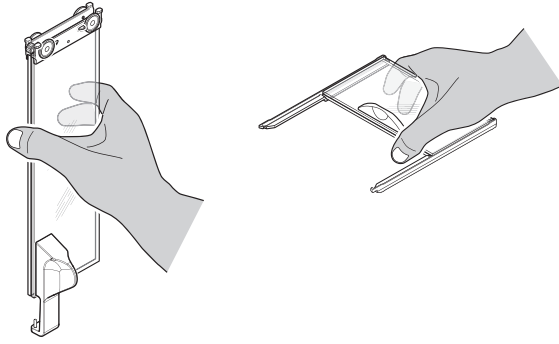

After cleaning reinstall all components in reverse order through the observance of the important notes.

**Important note**

- Side door glass panels: The guide pin must be placed in the guide slot (C).
- After inserting the glass doors (side and top), close the top cover so that they can not fall out.
- Front glass: The writing "front" must be show forwards.

## 12 Interface Specification

### 12.1 RS232C Interface

Each balance is equipped with an RS232C Interface as standard for the attachment of a peripheral device (e.g. printer or computer).

Schematic	Item	Specification
	Interface type	Voltage interface according to EIA RS-232C/DIN66020 CCITT V24/V.28)
	Max. cable length	15 m
	Signal level	Outputs: +5 V ... +15 V (RL = 3–7 kΩ) –5 V ... –15 V (RL = 3–7 kΩ) Inputs: +3 V ... +25 V –3 V ... –25 V
	Connector	Sub-D, 9-pole, female
	Operating mode	Full duplex
	Transmission mode	Bit-serial, asynchronous
	Transmission code	ASCII
	Baud rates	600, 1200, 2400, 4800, 9600, 19200, 38400 (software selectable)
	Bits/parity	7-bit/none, 7-bit/even, 7-bit/odd, 8-bit/none (software selectable)
	Stop bits	1 stop bit
	Handshake	None, XON/XOFF, RTS/CTS (software selectable)
	End-of-line	<CR><LF>, <CR>, <LF> (software selectable)
	Power supply for 2nd display	+ 12 V, max 40 mA (software selectable, 2nd display mode only)

### 12.2 USB Device Interface

Each balance is equipped with an "USB Device" Interface as standard for the attachment of a peripheral device (e.g. computer).

**Note:** This interface is not suitable to communicate with a Printer.

Schematic	Item	Specification										
<table border="1" style="margin-top: 10px;"> <tr> <td>1</td> <td>VBUS (+5 VDC)</td> </tr> <tr> <td>2</td> <td>D- (Data -)</td> </tr> <tr> <td>3</td> <td>D+ (Data +)</td> </tr> <tr> <td>4</td> <td>GND (Ground)</td> </tr> <tr> <td>Shield</td> <td>Shield</td> </tr> </table>	1	VBUS (+5 VDC)	2	D- (Data -)	3	D+ (Data +)	4	GND (Ground)	Shield	Shield	Standard	In conformity with USB Specification Revision 1.1
	1	VBUS (+5 VDC)										
	2	D- (Data -)										
	3	D+ (Data +)										
	4	GND (Ground)										
Shield	Shield											
Speed	Full speed 12 Mbps (requires shielded cable)											
Function	CDC (Communication Device Class) serial port emulation											
Power usage	Suspended device: Max 10 mA											
Connector	Type B											

## 12.3 Aux Connection

You can connect the METTLER TOLEDO "ErgoSens" or an external switch to socket Aux. This allows you to start functions such as taring, zeroing or printing.

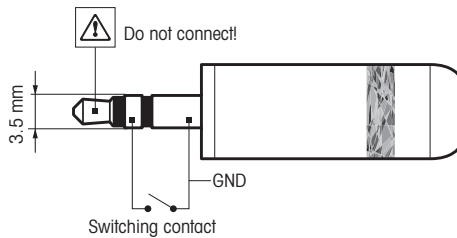

### External connection

Connector:  
3.5 mm stereo jack connector

Electrical data:  
Max. voltage 12 V  
Max. current 150 mA

## 12.4 MT-SICS Interface Commands and Functions

Many of the instruments and balances used have to be capable of integration in a complex computer or data acquisition system.

To enable you to integrate balances in your system in a simple manner and utilize their capabilities to the full, most balance functions are also available as appropriate commands via the data interface.

All new METTLER TOLEDO balances launched on the market support the standardized command set "METTLER TOLEDO Standard Interface Command Set" (MT-SICS). The commands available depending on the functionality of the balance.

For further information please refer to the Reference Manual MT-SICS downloadable from the Internet under

► [www.mt.com/sics-newclassic](http://www.mt.com/sics-newclassic)

## 13 Technical Data

### 13.1 General Data

#### Power Supply

- AC/DC adapter Primary: 100 V–240 V AC, -15%/+10%, 50/60 Hz  
Secondary: 12 V DC, 2.5 A (with electronic overload protection)
- Cable to AC/DC adapter 3-core, with country-specific plug
- Power supply to the balance 12 V DC,  $\pm 3\%$ , 1.0 A, maximum ripple 80 mVpp



Use only with a tested AC Adapter with SELV output current.

Ensure correct polarity 

- Power consumption in standby < 1 W (**MT.GREEN**)

#### Protection and Standards

- Overvoltage category II
- Degree of pollution 2
- Protection Protected against dust and water
- Standards for safety and EMC See Declaration of Conformity (separate document)
- Range of application For use only in closed interior rooms

#### Environmental conditions

- Height above mean sea level up to 4000 m
- Ambient temperature range 10 to 30 °C
- Relative air humidity 10% to 80% up to 31 °C, linearly decreasing to 50% at 40 °C, non-condensing
- Warm-up time At least 60 minutes after connecting the instrument to the power supply; when switched on from standby, the instrument is ready for operation immediately.

#### Materials

- Housing/Terminal Die-cast aluminum / Plastic (PA12)
- Weighing pan Stainless steel X2CrNiMo 17-12-2 (1.4404)
- Draft shield element Stainless steel X2CrNiMo 17-12-2 (1.4404)
- Draft shield Plastic (PBT), glass
- In-use-cover Plastic (PET)

### 13.2 Explanatory Notes for the METTLER TOLEDO AC Adapter

METTLER TOLEDO Balances are operated with a certified external power supply which conforms to the requirements for Class II double insulated equipment and it is not provided with a protective earth connection but with a functional earth connection for EMC purposes. Information about conformance of our products can be found in the "Declaration of Conformity" which is coming with each product.

Consequently an earth bonding test is not required. Similarly it is not necessary to carry out an earth bonding test between the supply earth conductor and any exposed metalwork on the balance.

In case of testing with regard to the European Directive on general product safety the power supply and the balance has to be handled as Class II double insulated equipment.

Because high resolution balances can be sensitive to static charges a leakage resistor, typically 10 kOhm, is connected between the earth connector and the power supply output terminals. The arrangement is shown in the equivalent circuit diagram. This resistor is not part of the electrical safety arrangement and does not require testing at regular intervals.

#### Equivalent circuit diagram

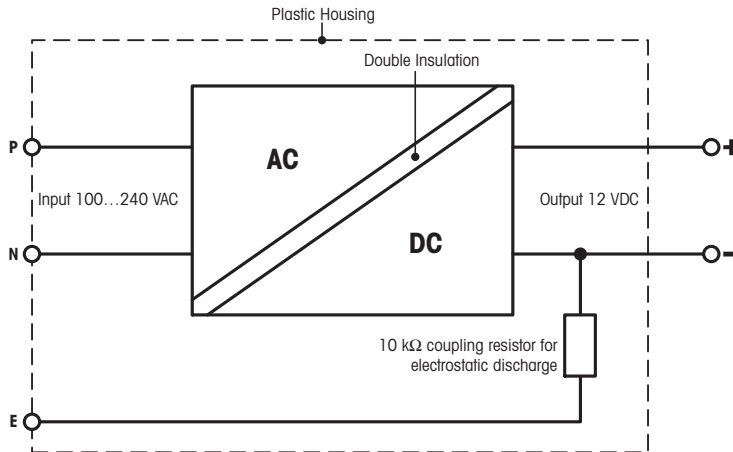

### 13.3 Model-Specific Data

#### Technical Data

Model	MS105	MS105DU	MS205DU
<b>Limit values</b>			
Maximum capacity	120 g	120 g	220 g
Maximum capacity, fine range	—	42 g	82 g
Readability	0.01 mg	0.1 mg	0.1 mg
Readability, fine range	—	0.01 mg	0.01 mg
Repeatability, sd (at nominal load)	0.04 mg	0.08 mg	0.08 mg
Repeatability, sd (at low load)	0.02 mg (20 g)	—	—
Repeatability, fine range, sd (at nominal load)	—	0.03 mg	0.05 mg
Repeatability, fine range, sd (at low load)	—	0.02 mg (20 mg)	0.02 mg (20 mg)
Linearity deviation	0.1 mg	0.15 mg	0.2 mg
Sensitivity offset (test weight)	0.4 mg (100 g)	0.4 mg (100 g)	0.8 mg (200 g)
<b>Typical values</b>			
Repeatability, sd (at nominal load)	0.03 mg	0.06mg	0.07 mg
Repeatability, sd (at low load)	0.015 mg (20 g)	0.015 mg (20 g)	0.015 mg (20 g)
Linearity deviation (withing 10 g)	0.02 mg	0.02 mg	0.02 mg
Minimum sample weight (acc. to USP)	30 mg	30 mg	30 mg
Minimum sample weight (U=1 %, k=2)	3 mg	3 mg	3 mg
Minimum sample weight OIML	1 mg	1 mg	1 mg
Settling time	8 s	4 s	4 s
Settling time, fine range	—	8 s	8 s
Balance dimensions (W x D x H)	247x358x331 mm	247x358x331 mm	247x358x331 mm
Weighing pan dimensions	Ø 80 mm	Ø 80 mm	Ø 80 mm
Usable height of draft shield	234 mm	234 mm	234 mm
Weight of balance	6.8 kg	6.8 kg	6.8 kg
Internal adjustment	yes, FACT	yes, FACT	yes, FACT
<b>Weights for routine testing</b>			

Model	MS105	MS105DU	MS205DU
OIML CarePac	#11123002	#11123002	#11123001
Weights	100 g F2, 5 g E2	100 g F2, 5 g E2	200 g F2, 10 g F1
ASTM CarePac	#11123102	#11123102	#11123101
Weights	100 g 1, 5 g 1	100 g 1, 5 g 1	200 g 1, 10 g 1

sd = Standard deviation

Model	MS204
<b>Limit values</b>	
Maximum capacity	220 g
Maximum capacity, fine range	—
Readability	0.1 mg
Readability, fine range	—
Repeatability, sd (at nominal load)	0.09 mg
Repeatability, sd (at low load)	0.07 mg (20 g)
Repeatability, fine range, sd (at nominal load)	—
Repeatability, fine range, sd (at low load)	—
Linearity deviation	0.2 mg
Sensitivity offset (test weight)	0.8 mg (200 g)
<b>Typical values</b>	
Repeatability, sd (at nominal load)	0.07 mg
Repeatability, sd (at low load)	0.05 mg (20 g)
Linearity deviation (withing 10 g)	—
Minimum sample weight (acc. to USP)	100 mg
Minimum sample weight (U=1 %, k=2)	10 mg
Minimum sample weight OIML	10 mg
Settling time	2 s
Settling time, fine range	—
Balance dimensions (W x D x H)	247x358x331 mm
Weighing pan dimensions	Ø 80 mm
Usable height of draft shield	234 mm
Weight of balance	6.8 kg
Internal adjustment	yes, FACT
<b>Weights for routine testing</b>	
OIML CarePac	#11123001
Weights	200 g F2, 10 g F1
ASTM CarePac	#11123101
Weights	200 g 1, 10 g 1

sd = Standard deviation



## 13.4 Dimensions

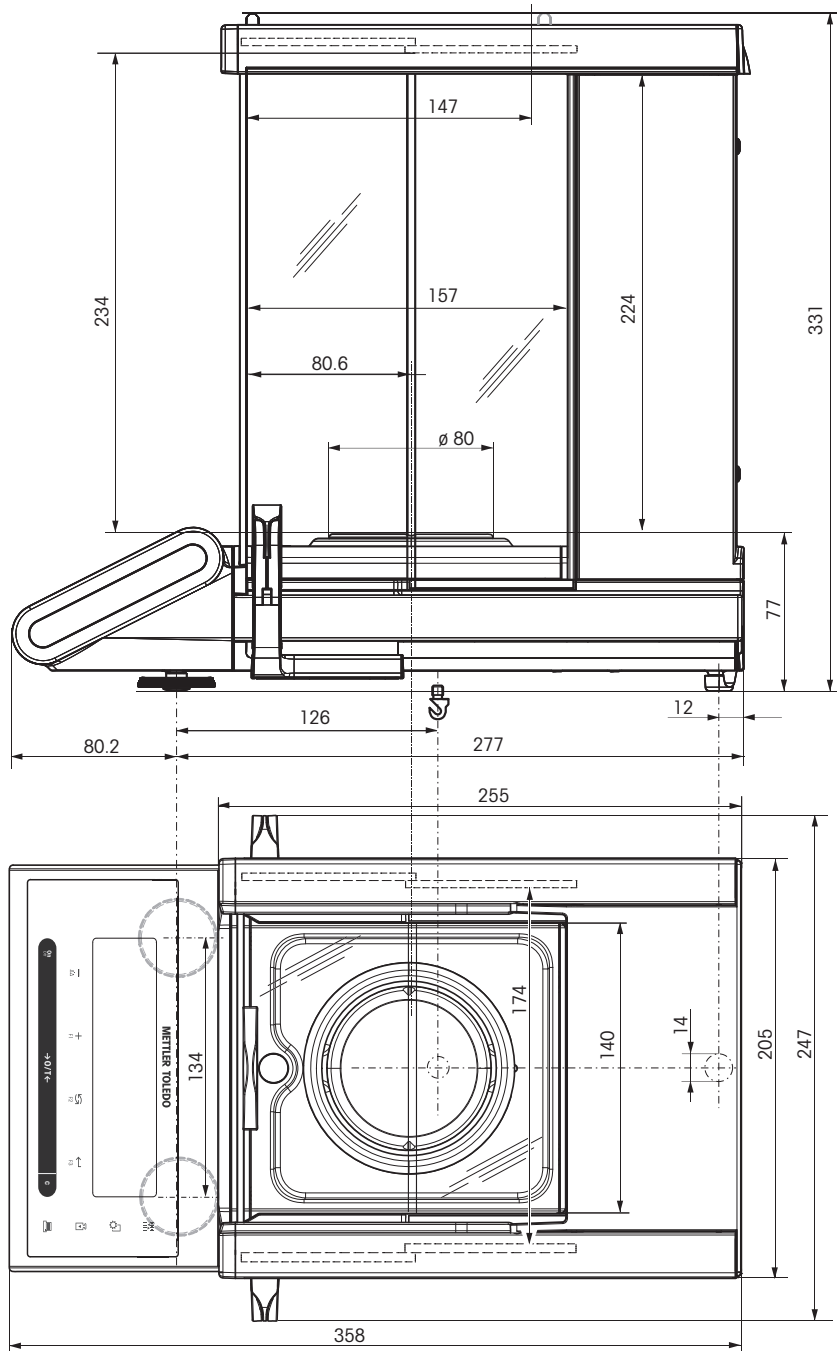

## 14 Accessories and Spare Parts

### 14.1 Accessories

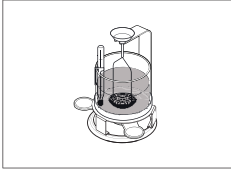
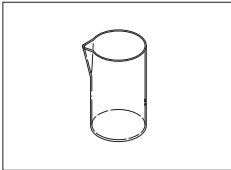
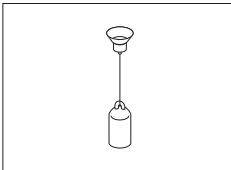
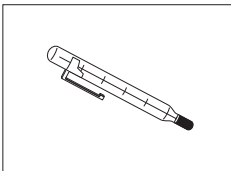
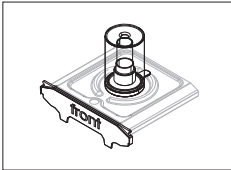
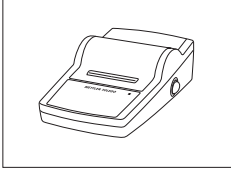
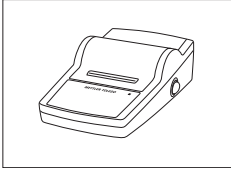
	Description	Part No.
<b>Density determination</b>		
	Density kit MS-DNY-54 for NewClassic MS Semi-Micro Balances	30004077
	Glass beaker, height 100 mm, Ø 60 mm	00238167
	Sinker for density of liquids in conjunction with Density Kit Calibrated (sinker + certificate) Recalibrated (new certificate)	00210260 00210672 00210674
	Calibrated thermometer with certificate	11132685
<b>Pipette check</b>		
	Evaporation trap MS-ET-54 for NewClassic MS Semi-Micro Balances	30014460
<b>Printers</b>		
	RS-P25 printer with RS232C connection to instrument	11124300
	Paper roll, set of 5 pcs	00072456
	Paper roll, self-adhesive, set of 3 pcs	11600388
	Ribbon cartridge, black, set of 2 pcs	00065975
	RS-P26 printer with RS232C connection to instrument (with date and time)	11124303
	Paper roll, set of 5 pcs	00072456
	Paper roll, self-adhesive, set of 3 pcs	11600388
	Ribbon cartridge, black, set of 2 pcs	00065975

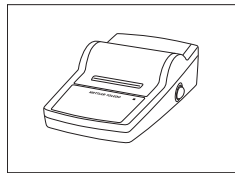
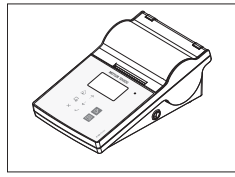
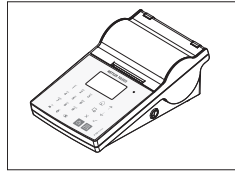
	<p>RS-P28 printer with RS232C connection to instrument (with date, time and applications)</p> <p>Paper roll, set of 5 pcs</p> <p>Paper roll, self-adhesive, set of 3 pcs</p> <p>Ribbon cartridge, black, set of 2 pcs</p>	<p>11124304</p> <p>00072456</p> <p>11600388</p> <p>00065975</p>
	<p>P-56RUE Thermal Printer with RS232C, USB and Ethernet connections, simple printouts, Date and Time, Label printing (limited).</p> <p>Paper roll, white, set of 10 pcs</p> <p>Paper roll, white, self-adhesive, set of 10 pcs</p> <p>Paper roll, white, self-adhesive labels, set of 6 pcs</p>	<p>30094673</p> <p>30094723</p> <p>30094724</p> <p>30094725</p>
	<p>P-58RUE Thermal Printer with RS232C, USB and Ethernet connections, simple printouts, Date and Time, Label printing, Balance applications: Statistics, Formulation, Totaling,</p> <p>Paper roll, white, set of 10 pcs</p> <p>Paper roll, white, self-adhesive, set of 10 pcs</p> <p>Paper roll, white, self-adhesive labels, set of 6 pcs</p>	<p>30094674</p> <p>30094723</p> <p>30094724</p> <p>30094725</p>

**Cables for RS232C interface**

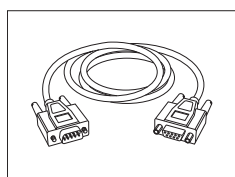
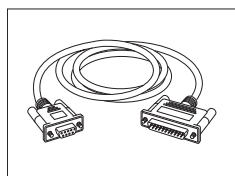
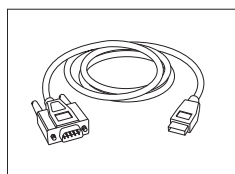
	<p>RS9 – RS9 (m/f): connection cable for PC, length = 1 m</p>	<p>11101051</p>
	<p>RS9 – RS25 (m/f): connection cable for PC, length = 2 m</p>	<p>11101052</p>
	<p>RS232 - USB converter cable – Cable with converter to connect a balance (RS232) to a USB port</p>	<p>64088427</p>

**Cables for USB interface**

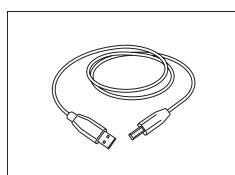
	<p>USB (A –B) connection cable for connection to PC, length = 1 m</p>	<p>12130716</p>
-------------------------------------------------------------------------------------	-----------------------------------------------------------------------	-----------------

**Cable replacement (wireless)**

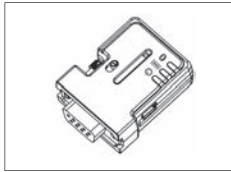

Bluetooth RS232 Serial Adapter ADP-BT-S for wireless connection between **printer** and Excellence balance\* or between **balance** and PC\*. Fits printers P-56 / P-58 and the following balance models (SW V2.20 or higher required): MS, MS-S/L, ML, PHS, JP, JS.

30086494

\* Bluetooth interface required

- 1 Bluetooth RS232 Serial Adapter (slave)
- 1 MT-DB9 male to female connector
- 1 MT-DB9 male to male connector

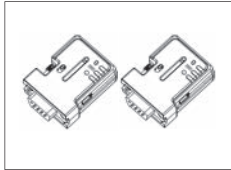

Bluetooth RS232 Serial Adapter set ADP-BT-P for wireless connection between printer and balance. Fits printers P-56 / P-58 and the following balance models (SW V2.20 or higher required): MS, MS-S/L, ML, PHS, JP, JS.

30086495

- 2 Bluetooth RS232 Serial Adapter paired (slave/master)
- 1 MT-DB9 male to female connector
- 1 MT-DB9 male to male connector

### Auxiliary displays

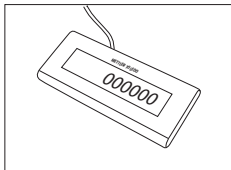

RS232 auxiliary display AD-RS-M7

12122381

### External switches

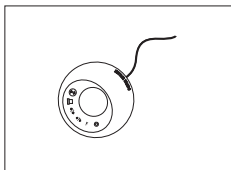

ErgoSens, optical sensor for hands-free operation

11132601

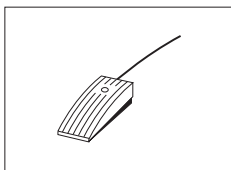

Auxiliary Footswitch with selectable function for balances

11106741

### Power supplies

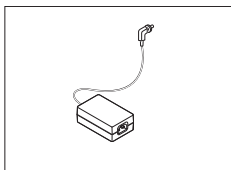

AC/DC adapter (without power cable) 100–240 V AC, 0.8 A, 50/60 Hz, 12 V DC 2.5 A

11107909

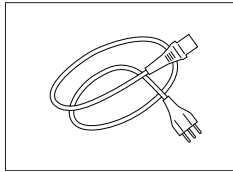

Country-specific 3-Pin power cable with grounding conductor.

Power cable AU	00088751
Power cable BR	30015268
Power cable CH	00087920
Power cable CN	30047293
Power cable DK	00087452
Power cable EU	00087925
Power cable GB	00089405
Power cable IL	00225297
Power cable IN	11600569
Power cable IT	00087457
Power cable JP	11107881
Power cable TH, PE	11107880
Power cable US	00088668
Power cable ZA	00089728

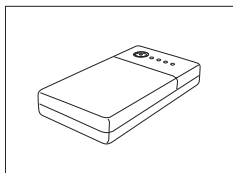

PowerPac-M-12V, for mains independent operation of balances, 12 VDC/1 A

12122363

#### Protective covers

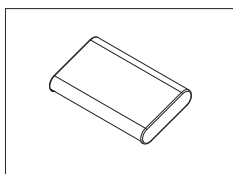

Protective cover for semi micro balances

30006615

#### Anti-theft devices

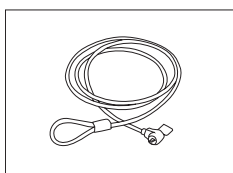

Steel cable

11600361

#### Software

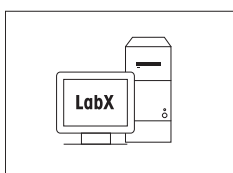

LabX direct balance (simple data transfer)

11120340

#### Transport cases

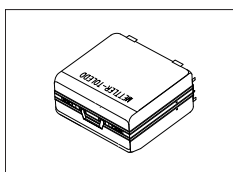

Transport case

30006317

## Adjustment weights

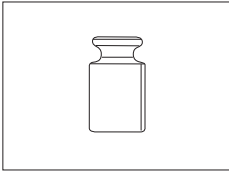

OIML / ASTM Weights (with calibration certificate) see [www.mt.com/weights](http://www.mt.com/weights)

## 14.2 Spare Parts

Drawing	Pos	Description	Part No.
	1	Side door back, left	11133079
	2	Side door front, left with handle	30003678
	3	Side door back, right	11133077
	4	Side door front, right with handle	30003677
	5	Top door back	11133081
	6	Top door front with handle	11133082
	7	Top cover	11142244
	8	Front glass lock, left	11142228
	9	Front glass lock, right	11142229
	10	Front glass panel	30003679
	11	Level window	11142253
	12	Weighing pan	30003777
	13	Draff ring	11142206
	14	Drip tray	30003778
	15	Plastic cap	11122623
	16	Weighing below balance cap	12104936
	17	Leveling foot	11106323

# Index

## A

Accessories	90
Adjusting	16
Adjustment	18, 27, 27, 28
Advanced Menu	23
Ambient conditions	13
Application "Density"	55
Application "Diagnostics"	31, 68
Application "Formulation"	46
Application "Multiplication Factor Weighing"	51
Application "Percent Weighing"	42
Application "Piece Counting"	39
Application "PipetteCheck"	61
Application "Routine Test"	65
Application "Statistics"	44
Application "Totaling"	49
Application "Weighing"	20
Application icons	11
Assign Application	30, 30, 30
Auto print	33
Automatic adjustment	16
Automatic shutoff	29
Automatic zero setting	29
Autozero	29
Aux connection	85
Average (Statistics)	44

## B

Backlight	29
Balance history	71
Balance information	73
Basic menu	23, 26
Baudrate	34
Beep	26, 27
Bit/Parity	34

## C

Calibration	27, 27
Calibration history	72
Cancel	25
Change settings	24, 24
Char Set	35, 37
Cleaning	82
Closing the menu	25
Control Limit	66
Conventions and symbols	7
Customer fine adjustment	18, 27

## D

Data communication format	33, 36
Date	26
Date format	28
Delivery inspection	13
Density	55
Density kit	55

Density table for distilled water	59
Density table for ethanol	60
Diagnose	31
Diagnostics	68
Diagnostics application	31
Dimensions	89
Display	29, 32
Display panel	11
Display test	69
Disposal	8
Distilled water	59
Dosing	27
Draft Shield	13, 82
DualRange	21

## E

End of Line	35, 37
Environment	27
ErgoSens	38, 85
Error messages	80
Ethanol	60
External key	38
External weight	17

## F

FACT	16, 28, 28
Factor Weighing	51
Fill up	47
Firmware update	78
Foot switch	85
Formulation	46
Fully automatic adjustment	16, 28
Function "Fill up"	47
Function PC-Direct	75

## G

Good Weighing Practice	65
GWP	65, 66

## H

Handshake	35
Header	32
Host	32, 36

## I

Icons	11
Input principle	24
Installing the components	13
Interface	
MT-SICS	85
Interface menu	23, 31
Interface RS232C	31, 84
Interface USB device	35, 84
Internal weight	17
Interval	38

## K

Key assign	30, 30, 30
Key beep	26

Key functions	10	Select menu topic	24
Key test	70	Selecting the location	13
<hr/>			
<b>L</b>		Service	31, 31, 82
Language	30	Service date reset	31
Leveling the balance	14	Service icon	31
Line feed	33	Service provider information	74
Liquid	55	Service reminder	31
Liquids	57	Shutoff	20, 29
Location	13	Signature line	32
<hr/>			
<b>M</b>		Single	32
Main Menu	25	Sinker	55, 57
Manual adjustment with external weight	17	Software update	78
Manual adjustment with internal weight	17	Solids	55
Menu	23, 25	SOP	66
Menu Advanced	23	Spare parts	94
Menu Basic	23, 26	Stability beep	27
Menu Interface	23, 31	Standard Deviation (Statistics)	44
Menu operation	24	Statistics	44
Menu protection	25	Status icons	11
Menu topic	24, 24, 25	Status messages	81
Motor test	71	Stop bit	35
MT-SICS	85	Submenu	24
Multiplication Factor Weighing	51	Switching	
<hr/>			
<b>N</b>		On	16
Net	21	Switching the balance on and off	20
Numerical values	24	Switching weight units	22
<hr/>			
<b>O</b>		Symbols and conventions	7
Operating temperature	16	<hr/>	
Operation keys	10	<b>T</b>	
<hr/>			
<b>P</b>		Taring	21
PC-DIR	31	Technical data dimensions	89
PC-Direct	75	Technical data general	86
Percent Weighing	42	Technical data model-specific	87
Performing a simple weighing	21	Time	26
Piece Counting	39	Time format	28
PipetteCheck	61	Topic	24, 24, 25
Power supply	14	Totaling	49
Print	22	Transmit data	22
Printer	31	Transporting the balance	16
Protect	25	<hr/>	
Protocol trigger	28	<b>U</b>	
<hr/>			
<b>R</b>		Unit	26, 26
Recall	22, 28	Unpacking	13
Repeatability test	68	USB device interface	35, 76, 84
Reset	27	USB-Driver installing	76
Routine Test	65	<hr/>	
RS232C interface	31, 84	<b>W</b>	
<hr/>			
<b>S</b>		Warm-up time	16
Saving settings	25	Warning Limit	66
Select menu	24	Weighing made simple	20
<hr/>			
		Weighing mode	27
		Weighing-in aid	22
		Weight unit	22, 26, 26
		<hr/>	
		<b>Z</b>	
		Zero print	33
		Zero range	29
		Zero setting	21
		Zeroing	29









## **GWP® – Good Weighing Practice™**

The global weighing guideline GWP® reduces risks associated with your weighing processes and helps to

- choose the appropriate balance
- reduce costs by optimizing testing procedures
- comply with the most common regulatory requirements

► [www.mt.com/GWP](http://www.mt.com/GWP)

[www.mt.com/NewClassic](http://www.mt.com/NewClassic)

For more information

### **Mettler-Toledo AG, Laboratory Weighing**

CH-8606 Greifensee, Switzerland

Tel. +41 (0)44 944 22 11

Fax +41 (0)44 944 30 60

[www.mt.com](http://www.mt.com)

Subject to technical changes.

© Mettler-Toledo AG 01/2014

11781416E en



\* 1 1 7 8 1 4 1 6 \*