



*Professional  
Weighing Equipment*

**MRB Series Mid Resolution Balances**  
Compact Scales



- MRB 500g
- MRB 1200g
- MRB 2500g
- MRB 6000g
- MRB 10000g

**Operation Manual**

## Table of Contents

<u>Section</u>	<u>Page</u>
Declaration of Conformity	3
Customer Service	4
Introduction	4
Safety	5
Weight Scale	6
Functions	7
Scale Description	8
Application & Conformity	9
Getting Started	9
Delivery	10
Assembly & Installation	10-11
Application Menu	11-12
Calibration	12-13
Maintenance & Service	13
Transportation & Storage	14
Warranty	14

# Declaration of Conformity

Declaration of conformity for apparatus with CE mark

We hereby declare that the product to which this declaration refers conforms to the following standards.

Electronic scale:MRB Compact Scales

## Models

MRB 500g

MRB 1200g

MRB 2500g

MRB 6000g

MRB 10000g

Mark applied	EU Directive	Standards
	2004/108/EC	EN 61326-1: 2006

Signature:



Boon Lim, R & D Manager

Date: 14. 11. 2012

LW Measurements LLC, 3510 Industrial Drive, Unit H Santa Rosa, CA 95403

# Customer Service

## **USA**

LW Measurements LLC, 3510 Industrial Drive,  
Unit H Santa Rosa, CA 95403

USA

Tel: (707) 542-2185

Fax: (707) 542-3285

<http://lwmeasurements.com>

## **EUROPE**

LW Measurements Europe Ltd  
Chalkwell Park House 700 London Road  
Westcliff-on-Sea Essex SS0 9HQ  
United Kingdom

Tel: 01702-476700

Fax: 01702-477380

<http://lwmeasurements.com>

# Introduction

What you should know about this Operation Manual:

Tree® Professional Weighing Equipment products are simple to operate. Nevertheless, you should read through these operating instructions in their entirety, so that you can make optimum use of the full potential of the weighing scale in your daily work activities.

These operating instructions contain guidance in the form of pictograms and keyboard diagrams, which should help in finding the required information:

For the labeling of potential hazards, please refer to the Safety proportion of this operation manual.

# Safety

## Representations & Symbols

Note: Important instructions, which involve safety, are highlighted with the appropriate mark:



## Safety recommendations

When using the weighing equipment in surroundings with increased safety requirements, the corresponding regulations must be observed.

The weighing scale may only be used with the power adapter supplied. Before connecting the power adapter to the scale, the user must ensure that the operating voltage stated on the power adapter is compliant with the mains voltage. If not, please contact Customer Service at the address above.

If the power adapter or its cable is damaged, the weighing scale must immediately be disconnected from the electricity supply (pull out the power adapter).

If there should be any reason to believe that it is no longer safe to operate the scale, it should be immediately unplugged from the electricity supply (pull out power adapter) and secured against inadvertent operation.

In carrying out maintenance work, it is essential to follow the recommendations set out in maintenance and servicing.

The weighing scale must not be operated in an area subject to explosion risks.

Care must be taken when weighing liquids to ensure that no liquid is spilled into the inside of the scale or into connections on the rear of the equipment or the power adapter. If liquid is spilled on the scale, it must immediately be unplugged from the main electricity supply (pull out power adapter).

The weighing scale may be operated after it has first been inspected by a service technician.

These operating instructions must be read by each user and should be easily accessible at the workplace at all times.

# Weight Scale

## Construction & Functions

The weighing scale consists of the following parts;

- The Scale body (1)
- Scale pan (2)
- The adapter
- Operation manual



# Functions

## Technical Data

Model number	Capacity	Division	Weighing pan Size
MRB 500	500 g	0.1 g	175 x 160 mm
MRB 1200	1200 g	0.1 g	175 x 160 mm
MRB 2500	2500 g	0.1 g	175 x 160 mm
MRB 6000	6000 g	1 g	175 x 160 mm
MRB 10000	10000 g	1 g	175 x 160 mm
Package (Standard carton)	29.8 x 21.6 x 8.8.5 (cm <sup>3</sup> )		
Package (Master carton)	12 Units in one box: 61x48.5x38 (cm <sup>3</sup> )		
Operating Temperature	0-40C°		
Power Source	6 x AA batteries or AC/DC Adapter 9V / 100mA		

## Features

- Auto zero tracking
- Auto shut off
- Low battery indication
- Large LCD (6 digits, 15 mm high)
- Large square weighing pan
- Auto calibration
- Selectable auto backlight
- Net weight indication
- Weighing units: kg,g, lb., oz., lb:oz
- 1/2000~1/15000 division available

# Scale Description

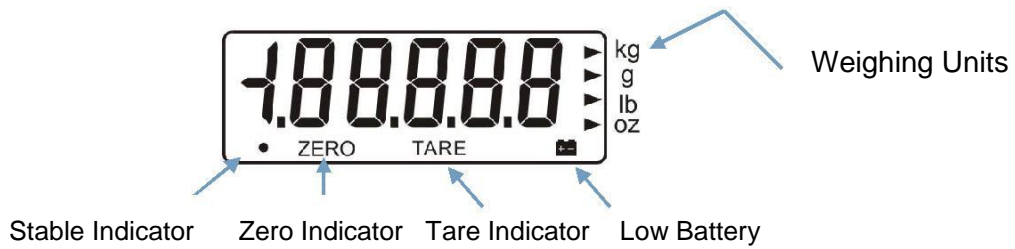
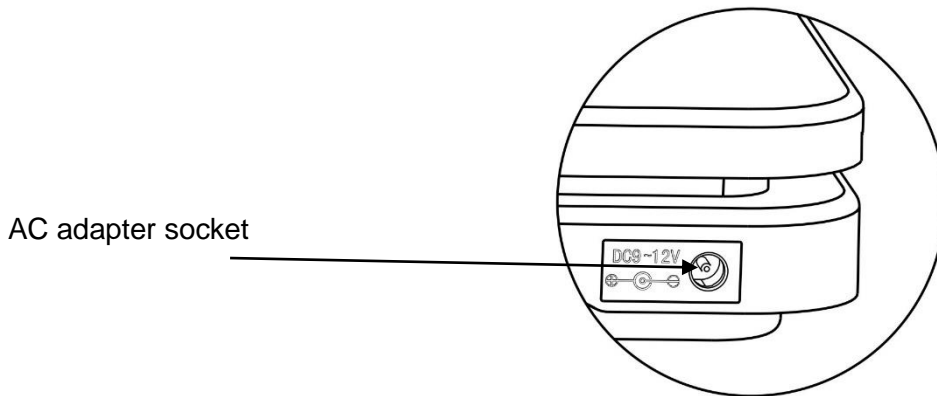
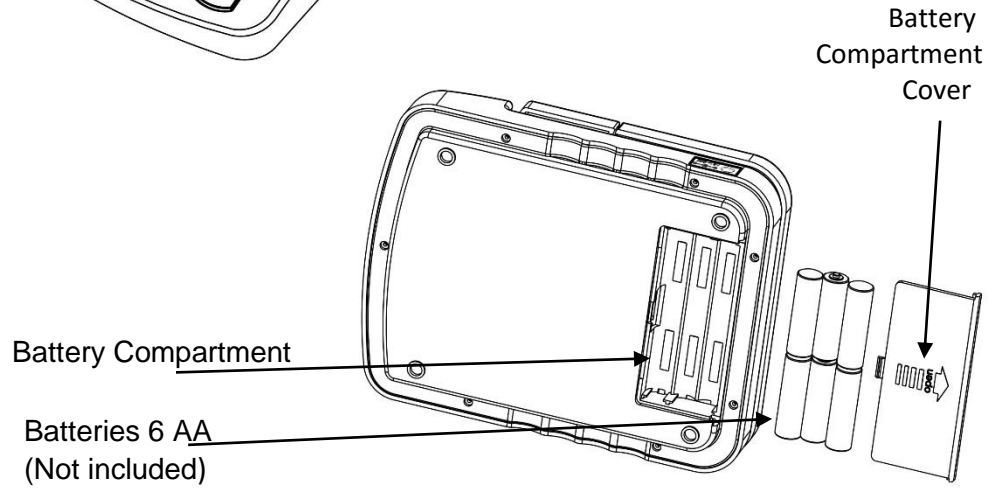
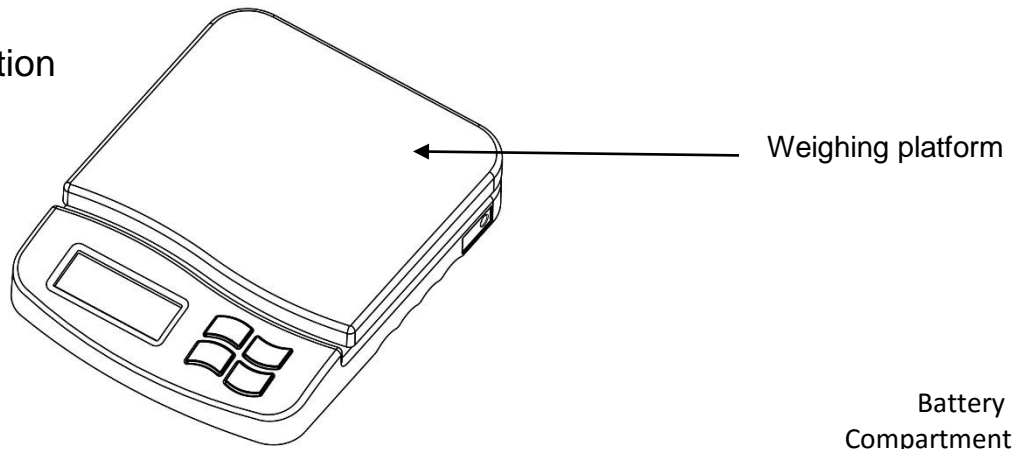



# Application & Conformity

The Following are instructions of how to correctly use the weight scale:

The weighing scale may only be used for the weighing of solid-materials and of liquids filled into secure containers.

The maximum capacity load of the weighing scale must never be exceeded, otherwise the weighing scale may be damaged.

In using the weighing scale in combination with other devices as well as with devices produced by other manufacturers, the appropriate regulations for the safe use of the relevant attachments and their application in accordance with instructions must be observed.

The weighing scale has been manufactured and tested in accordance with the standards and recommendations set out in the declaration of conformity.

The power adapter supplied for the weighing scale complies with the appropriate electrical protection class.

The following applies to all MRB series weighing machines:

**Power supply:**

- Input: 120V or 230V AC (+/-15-20%); 60Hz
- Output: 9v DC 100mA

**Allowable ambient conditions:**

- Temperature: 0°C - 40°C / 32 - 104°F
- Relative humidity: 25% - 85%, non-condensing

If you have any questions on the technical data or require detailed technical information on your balance, please contact your technical representative

## Getting Started

The scale is packaged in an environmentally-friendly carton, which provides optimum protection for the balance during transportation.

We suggest that you keep the original packaging in order to avoid damage if you are shipping or transporting the scale to a different location. It is also the best way to keep it in the best conditions if it will not be used for an extended period of time.

In order to avoid damage, please follow the instructions provided below, when unpacking the scale:

- Unpack the scale carefully.
- When outside temperatures are very low, the scale should be stored for a couple hours and kept in its box in a dry room at normal temperature, so that no condensation settles on the unit when opening the box.
- Check the scale immediately after unpacking for any external visual damage. If there is any damage on scale, contact customer service immediately.
- If the scale is not to be used immediately after purchase, it should be stored in a dry place where fluctuations in temperature are low. (Reference pg.).
- Read through these operating instruction, before you work with the unit and pay attention to the Safety recommendations (reference Safety pg. 6).

## Delivery

Inspect delivery for completeness immediately upon unpacking all components.

### Checklist for complete delivery

	Component delivered present yes / no
Weighing unit body	
Weighing pan	
Power adapter	
Operating manual	

## Assembly & Installation

The weighing scale is delivered in a partly dismantled condition. Assemble the individual components in the following sequence:

- Place your machine on a level, clean, and dry surface to obtain accurate readings.
- Place the plastic platter on top of the scale, flat side facing up so the platter sits firmly on the machine with the four “legs” inserted into the corresponding four receptacles.
- Place the stainless steel platter on top of the plastic platter with the flat side facing up.
- Unwrap and place the clear plastic bowl, open side facing up, on top of the stainless platter.

### Connecting the AC Adapter

The following Safety recommendations must be observed when connecting the balance:



## DANGER

The Scale should only be connected to the mains voltage socket with the power adapter supplied. Check before connecting the power adapter to the mains socket, that the operating voltage stated on the power adapter complies with the local mains voltage. If the operating voltage is not the same as the mains voltage, the power adapter must not be connected to the mains socket and contact customer service.

### Placement of Scale

The location in which the scale is placed is very important in order for the scale to work to its full potential. Certain conditions can affect the capabilities of the scale, conditions like: the presence of air flow, variations in temperature, and direct sunlight. Please follow the recommendations given below in choosing a location to place your scale.

- Place the scale on a solid, firm and preferably vibration-proof, horizontal base
- Make sure that the weighing machine cannot be shaken or knocked over
- Protect from direct solar radiation
- Avoid drafts and excessive temperature fluctuations
- Avoid placing the scale near or on any magnetic surfaces.

## Application Menu

### Function settings

To enter the function setting mode, press the ON/OFF key to turn the power off. Then press and hold the ZERO key and then press the ON/OFF key again. The display will show A\_ON or A\_OFF

### Auto backlight mode

Press the UNIT key, the display will show L\_ON, L\_OFF, or L\_Au. Press the ZERO key to select. L\_ON means the auto backlight function is active. L\_OFF means the auto backlight function is inactive, and L\_Au means the auto backlight function is on Auto

### Key Functions

- ON/OFF KEY is used to turn the Scale on or off.
- ZERO KEY sets or re-adjusts the machine into the correct zero position.
  - **Zero Range: 0-10% of full capacity**
- TARE KEY subtracts the gross weight on the platter (box or container, etc) to the tare weight.
  - **Tare Range: 10- 100% of full capacity. Multiple TARE allowed within capacity.**

- UNIT KEY is used to toggle between different weighing units.

## Clearing tare weight

- Place an empty container on the platter. Press the TARE key. The WEIGHT display shows 0.000.

When the container is removed from the platter, the WEIGHT display will show a minus (-) value which is the weight of the container

## Clearing previous tare value

Remove the weight from the platter then press the TARE key so that the TARE indicator will turn off and the WEIGHT display returns to Zero.

## Weighing procedures

Whenever possible, before weighing, please allow the weighing machine to warm up for at least 10 minutes after turning it on. This will help to ensure optimal functioning and operation.

- Press the ON/OFF key to turn on the weighing machine. The display will show all segments for a few seconds and then the “0” will appear.
- Press the UNIT key to select the desired weighing unit – “kg”, “g”, “lb”, “oz”, “lb:oz”.
- To begin weighing, place the objects to be weighed in a weighing container or directly on the platter.
- The stable indicator will display when the reading becomes stable.

## Calibration

**Note:** Calibration is done in the factory. Don't re-calibrate the machine unless it is not accurate. The weighing machine should be allowed to warm up for at least 10 minutes before calibration.

- Before entering calibration mode, press the ON/OFF key to turn the power on for 1 minute.
- Next press the ON/OFF key again to turn the power off.
- Press and hold the UNIT key and then press the ON/OFF key. The display will show “CALu=”.
- Press the UNIT key to select the calibration weight units ( g, lb, etc). Press the ZERO key to select the calibration weight. The display will show xxxxx. The X will be flashing. Press the UNIT key to move the flashing digit to the right. Press the TARE key to increase the flashing digit.

**NOTE:** *X is the calibration weight which can be set according to your requirements. The weight needed when re-calibrating your Tree scale needs to be at least half (1/2) of the capacity of the scale with two thirds (2/3) being ideal as this will give you the most accurate reading.*

**(Ex: For a 10,000g scale you would need at least 5,000g)**

- Press the Zero key to confirm the calibration weight. The display will show CAL and then the AD value. Once the stable indicator “(.)” is displayed, press the UNIT key. The display will flash the calibration weight.
- Place the calibration weight on the platter. After the stable indicator “(.)” is displayed, press the UNIT key. The display will show “-----“, then the AD value. The calibration is now finished.
- To return to the weighing mode, press the ON/OFF key to turn the power off. Press the ON/OFF key again to turn on the power and return the machine to weighing mode. Place the weight on the platter again to ensure the weighing is correct. If not, repeat the calibration process.

## Maintenance & Service



**DANGER**

For maintenance-work, the balance must be disconnected from the power supply (remove power adapter plug from socket). Also ensure that the balance cannot be connected to the power supply during the work by a third party.

Make sure that no liquid spills into the scale while performing maintenance work. If liquid is spilled on the scale, it must be inspected by a service technician.

Regularly perform maintenance to the weighing pan and the weighing pan holder by removing any dirt or dust from under the weighing pan and on the weighing scale housing. Use a soft brush or a soft, lint-free cloth, moistened with a mild soap solution



**CAUTION**

Never use solvents, acids, alkalis, paint thinners, scouring powders or other aggressive or corrosive chemicals for cleaning; these substances can cause damage to the surfaces of the scale housing.

## Transportation & Storage

Your weighing machine is a precision instrument, treat it carefully. Avoid shaking, severe impacts and vibration during the transportation. Make sure that there are no marked temperature fluctuations during the transportation and that the weighing machine does not become damp (condensation).

If you would like to take the weighing machine out of service for an extended period, disconnect it from the electricity supply, clean it thoroughly (refer to Maintenance & Service) and store it in a place which meets the following conditions:

- No violent shaking, no vibrations
- Minimum temperature fluctuations
- No direct solar radiation
- Minimum moisture

## Warranty

The products are under warranty against factory defects for a period of two (2) years from the date of shipment.

For Customers within the lower 48 states of the continental United States. LW Measurements will pay for freight both ways for the first 30 days after purchase. After 30 days expire the customer is responsible for shipping the product back to us. After the product is received we will inspect it and as necessary we will repair or replace and will ship the product back to the customer at our expense.

Any new scales returned for warranty must be properly packaged in the original box. If they are not properly packed in the original box, the customer pays for shipping cost. If we determine there is a factory defect, we will pay for the shipping back. If we determine that it is not a factory defect, the customer will pay shipping.

For Customers outside the lower 48 States, including Mexico, Canada, Puerto Rico, Hawaii, Alaska and all other countries, customers must pay for shipping.

Our warranty does not cover misuse or neglect including but not limited to battery or water damage, overloading, and chewed or cut wires. If the product is found to have been misused or damaged by the customer, LW measurements is not responsible for the cost of return.

For warranty claims please go online to [lwmeasurements.com](http://lwmeasurements.com) and fill out the warranty submission form or call your customer service representative.