

Pipette Accuracy Tester

PT-Series

AD-4212B-PT

AD-4212A-PT

FX-300i-PT

INSTRUCTION MANUAL



© 2011 A&D Company, Limited. All rights reserved.

No part of this publication may be reproduced, transmitted, transcribed, or translated into any language in any form by any means without the written permission of A&D Company, Limited.

The contents of this manual and the specifications of the instrument covered by this manual are subject to change for improvement without notice.

Microsoft, Windows, Excel and Word are either registered trademarks or trademarks of Microsoft Corporation in the United States and/or other countries.

CONTENTS

1. INTRODUCTION	2
1-1 Unpacking the Tester	2
1-2 Description of Each Component.....	3
1-3 WinCT-Pipette, Software for Pipette Accuracy Testing.....	4
1-4 Function of the Evaporation Trap	5
1-5 Description of a Sample Cup.....	5
2. ASSEMBLING THE TESTER.....	6
2-1 AD-4212B-PT / AD-4212A-PT	6
2-2 FX-300 <i>i</i> -PT	8
3. PRECAUTIONS BEFORE USE	10
4. ANTI-STATIC TREATMENT	11
5. INSTALLING WinCT-Pipette	11
6. CONNECTING A PC TO THE BALANCE.....	12
6-1 Connecting a PC	12
6-2 Checking COM Port Numbers.....	13
7. CALIBRATING THE BALANCE	14
7-1 AD-4212B-PT / AD-4212A-PT	14
7-2 FX-300 <i>i</i> -PT	15
8. PREPARATION BEFORE USE.....	16
8-1 Filling the Evaporation Trap with Water.....	16
8-2 Preparing the Test Liquid.....	16
8-3 Preparing the Water-absorbent Sheet.....	16
8-4 Using the Thermometer.....	17
9. MEASUREMENT	21
9-1 Measuring Procedure	21
9-2 Judging the Results	21
9-3 Example Causes of Measurement Errors	21
10. AD-4212B-PT / AD-4212A-PT	23
10-1 Factory Settings.....	23
10-2 Display Lock Function	24
10-3 Auto Print Mode	24
11. TROUBLESHOOTING	25
12. SPECIFICATIONS.....	26
12-1 Options	27
13. APPENDIX	28

1. INTRODUCTION

The PT series Pipette Accuracy Tester performs an accuracy test of the volume of a pipette in accordance with ISO 8655.

This manual describes how the PT series Pipette Accuracy Tester works and how to get the most out of it in terms of performance. It includes how to assemble the tester, how to measure and how to use the software, WinCT-Pipette, for pipette accuracy testing.

Read this manual thoroughly before using the tester and keep it at hand for future reference.

For detailed information on handling the balance, refer to the instruction manual for the balance used.

NOTE ISO 8655 is the international standard that includes pipette calibration and specifies a test method for accuracy of the pipette volume. For detailed information, visit our web site.

1-1 Unpacking the Tester

NOTE The pipette accuracy tester is contained in a carrying case. The case is only for carrying the tester and is not solid enough to endure transportation. So, do not transport the tester using the carrying case. When transporting the tester, be sure to use the original packing material.

When handling the tester, be careful not to drop it, even if it is placed in the carrying case.

The illustrations below show what the PT series consists of. Note that the USB converter is shipped in a separate package, but it can be placed in the carrying case as shown below.

A shoulder belt and a key are provided with the carrying case. Use the shoulder belt to carry the case.

NOTE Please confirm that the AC adapter type is correct for your local voltage and power receptacle type.

AD-4212B-PT / AD-4212A-PT

The connection cable provided as an accessory is one meter long.

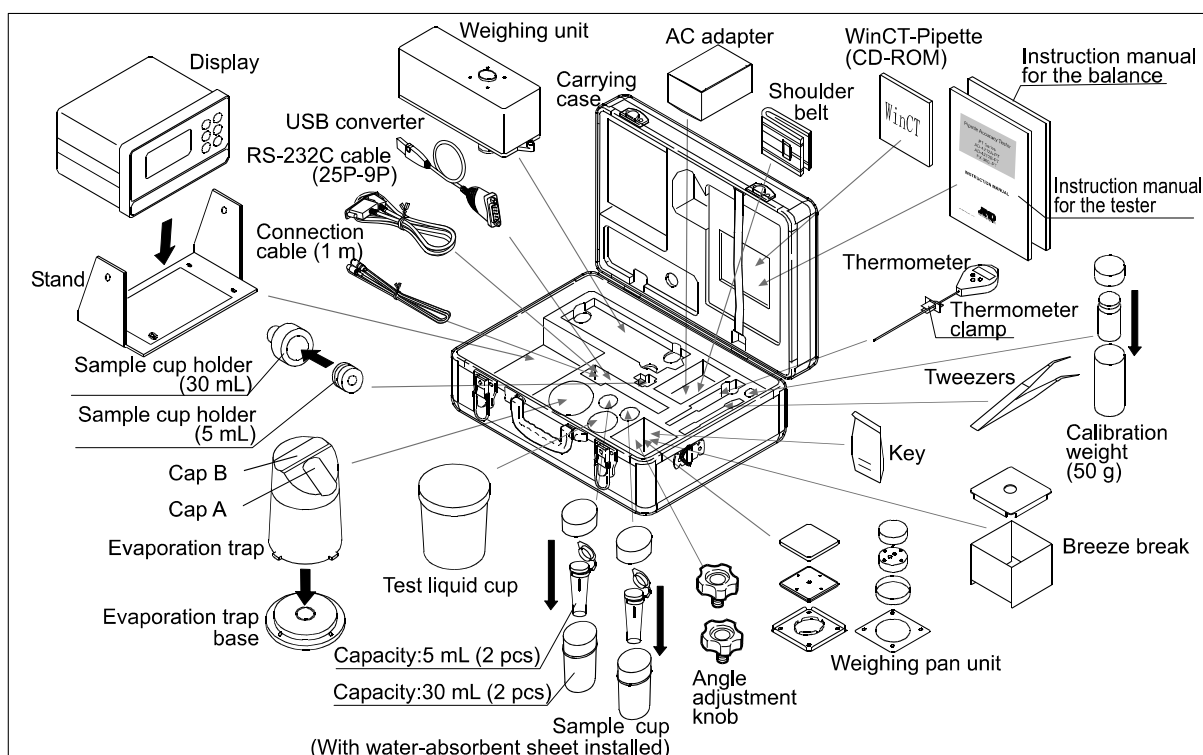

FX-300i-PT

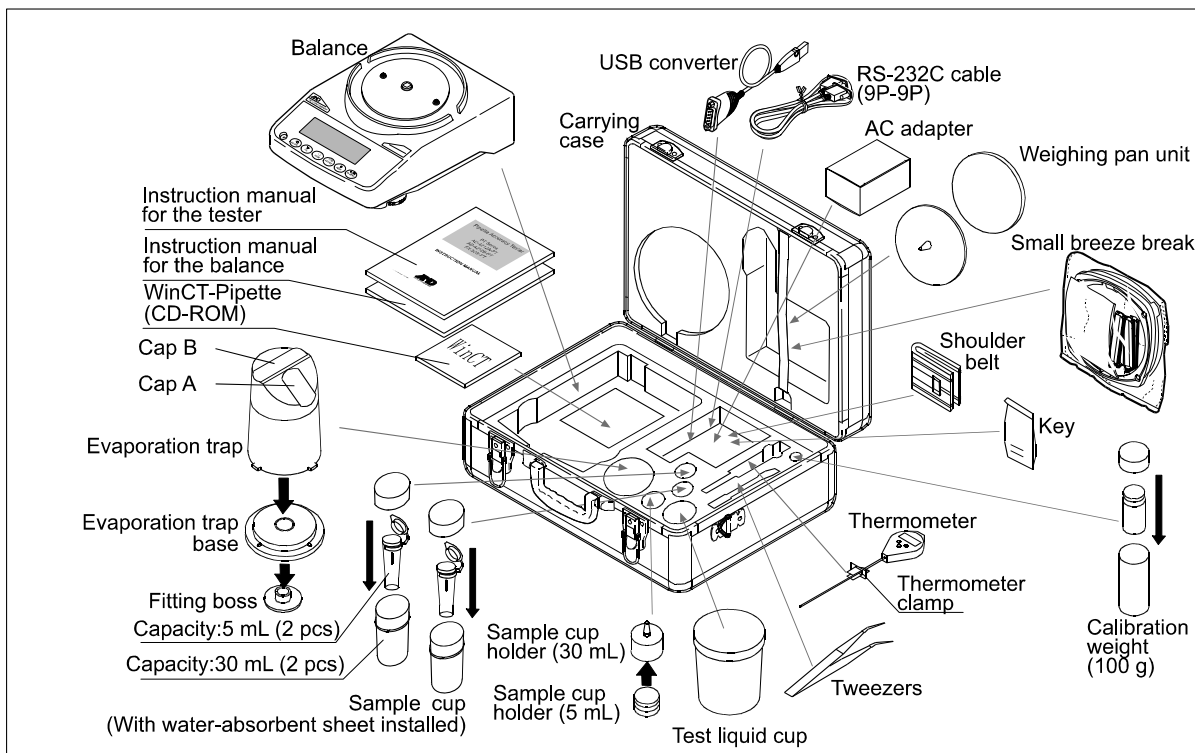

1-2 Description of Each Component

- Evaporation trap

A chamber to prevent the evaporation of the dispensed test liquid (distilled water). (Refer to “1-4 Function of the Evaporation Trap”).

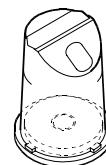

- Sample cup (Two types: 5 mL and 30 mL)

A measuring cup to contain the test liquid dispensed from a pipette, with a water-absorbent sheet installed, to prevent water droplets from remaining on the edge of the pipette tip.

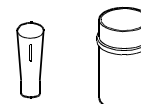

- Test liquid cup

A container to keep a test liquid such as distilled water.



- Thermometer (with a clamp)

Measures the temperature of the test liquid.



- RS-232C cable and USB converter

Connects to a PC (personal computer) to transmit the test values to the PC.



- WinCT-Pipette

Software for pipette accuracy testing to convert the test liquid mass into a volumetric value.

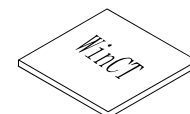

- Calibration weight (with a pair of tweezers to handle the weight)

A weight to calibrate the balance.

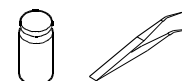

1-3 WinCT-Pipette, Software for Pipette Accuracy Testing

Features

The mass value of the distilled water dispensed from a pipette is transmitted from the balance to a PC. Using the temperature of the test liquid and the barometric pressure that are previously entered, the PC calculates the conversion factor (Z factor) from a mass value to a volumetric value and converts the mass value into a volumetric value automatically, using the Z factor.

- The measurement results are compared with the specifications previously entered, to perform judgment whether the pipette will pass or fail.
- Besides the pipette volume, test numbers, test dates and pipette information (manufacturer, model, serial number) can be recorded as test data. The test data, output to a printer or stored in the PC, allows easy management of pipette accuracy and reduces errors due to data mismanagement.
- The specifications of accuracy and repeatability can be entered either as an absolute value (μL) or as a relative value (percentage to the pipette volume).
- The mass value data from the balance can be transmitted to the PC either using a COM port or using a USB connection. (For a USB connection, use the accessory USB converter.)
- For testing various pipettes easily, multiple test conditions (pipette volume, number of measurements and specifications) can be set previously. When multiple operators are set previously, an operator can be selected easily as necessary.

NOTE For detailed information on WinCT-Pipette, refer to “How to use WinCT-Pipette.pdf” in the WinCT-Pipette CD-ROM.

Main Window

When WinCT-Pipette starts up, the window below opens

Specifications

Enter the pipette volume, specifications of accuracy and repeatability used for pass/fail judgment.

Pipette Volume		Specifications	
Accuracy (+/-)	Absolute Error	20	(μL)
	Relative Error	1.6	(μL)
Repeatability	S.D.	8	(%)
	C.V.	0.6	(μL)
		2	(%)

Measured Values

Displays the mass values transmitted from the balance and the volumetric values obtained using the Z factor.

No.	Measured Values	
	(μL)	(mg)
1	20.03	19.97
2	20.14	20.06
3	19.87	19.81
4	19.86	19.80
5	19.88	19.82
6	20.13	20.07
7	19.96	19.90
8	20.00	19.94
9	20.13	20.07
10	20.07	20.01

Measurement Results

Displays the measurement results and judgment results.

Number of Measurements		Measurement Results	
Accuracy	Mean	10	(times)
	Absolute Error	20.007	(μL)
	Relative Error	0.007	(μL)
	Judgment	0.035	(%)
Repeatability	S.D.	Pass	
	C.V.	0.111	(μL)
	Judgment	0.556	(%)
		Pass	

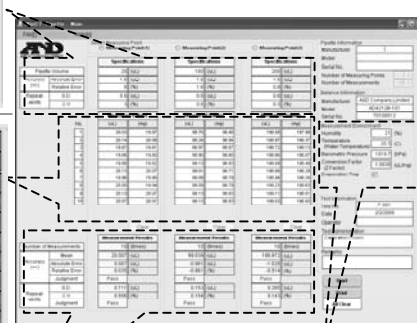

Measurement Environment	
Humidity	21 (%)
Temperature (Water Temperature)	20.5 (C)
Barometric Pressure	1019.7 (hPa)
Conversion Factor (Z Factor)	1.0030 ($\mu\text{L}/\text{mg}$)
Evaporation Trap	<input checked="" type="checkbox"/>

Measurement environment
Enter the ambient relative humidity, the distilled water temperature and the barometric pressure.

The Z factor is automatically calculated using the values of the distilled water temperature and the barometric pressure.

1-4 Function of the Evaporation Trap

In the pipette accuracy test using the gravimetric method, to obtain the mass of the test liquid, distilled water is dispensed from the pipette into the sample cup installed on the balance. The obtained value, however, is generally smaller due to evaporation loss of the test liquid. To prevent evaporation of the test liquid, the evaporation trap is used. The ISO 8655 standard recommends that the humidity of the measurement environment be greater than 50% RH.

Water is poured into the groove of the evaporation trap. This helps to maintain the humidity inside the evaporation trap high and reduces evaporation. Using the evaporation trap reduces the evaporation of the test liquid, compared with the value when the evaporation trap is not used. This yields a measurement environment where there is no need to consider measurement errors due to evaporation loss of the test liquid.

Another function of the evaporation trap is one as a breeze break, to prevent drafts in the measurement environment from influencing the weighing operation and enable a stable weighing.

The evaporation trap is designed for an easy dispensing of the test liquid. The upper part has a sloped surface so that the pipette can be inserted from obliquely above.

1-5 Description of a Sample Cup

When dispensing a test liquid from the pipette, to perform an accuracy test of the volume of a pipette, a possible cause of errors is water droplets remaining on the edge of the pipette tip. Using the water-absorbent sheet in the sample cup prevents this and increases the accuracy of a test.

As shown in the illustration below, a water-absorbent sheet is rolled into a cylinder and is placed along the inner wall of the sample cup.

By dispensing the test liquid with the edge of the pipette tip touching the sheet, the sheet will absorb any droplet which may otherwise remain on the edge of the tip. Thus all the test liquid will be dispensed into the sample cup.

The water-absorbent sheets are made of a RoHS-compliant material for safety.

The sheet, once used, can be cleaned and used repetitively.

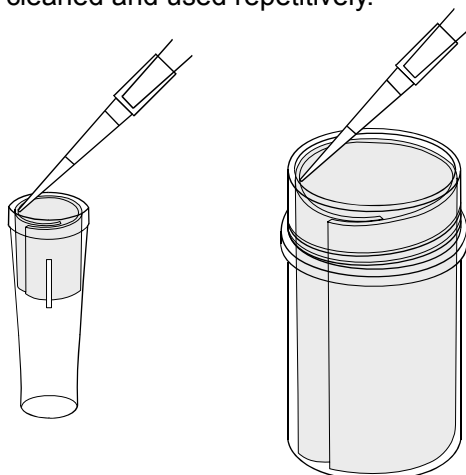

2. ASSEMBLING THE TESTER

2-1 AD-4212B-PT / AD-4212A-PT

1. Place the weighing unit on a solid table. For details on the installation site, refer to "3. PRECAUTIONS BEFORE USE".

Secure the display to the stand using the angle adjustment knobs. Connect the display and the weighing unit using the connection cable.

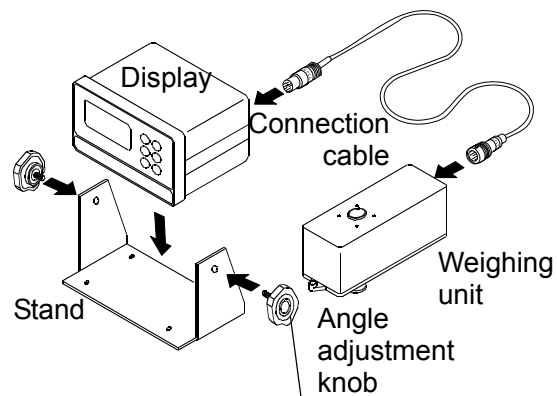

2. Install the evaporation trap base on the weighing unit.

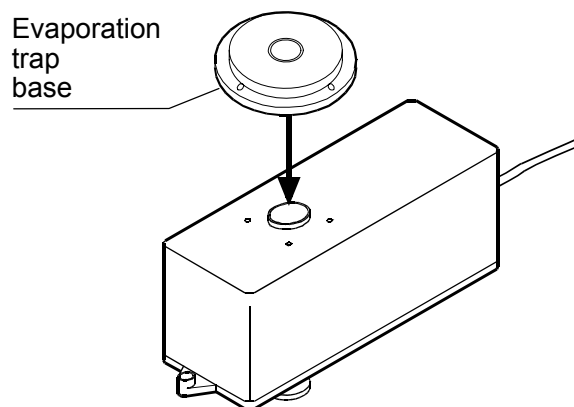

3. Install the sample cup holder (30 mL) on the base.

When the 30 mL sample cup is used:

Insert the sample cup into the holder.

When the 5 mL sample cup is used:

Insert the sample cup holder (5 mL) into the sample cup holder (30 mL), and then insert the sample cup

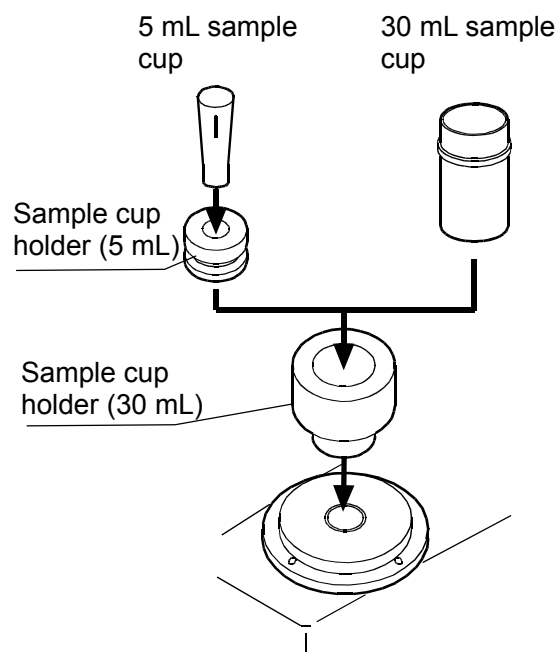

4. Install the lower part of the evaporation trap on the weighing unit, mating the tabs with the holes on the base.

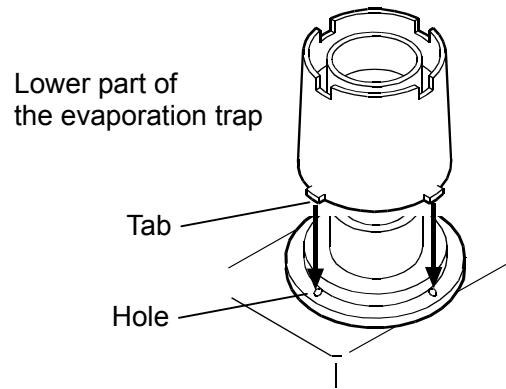

5. Attach the upper part of the evaporation trap to the lower part, mating the tab with the notch.

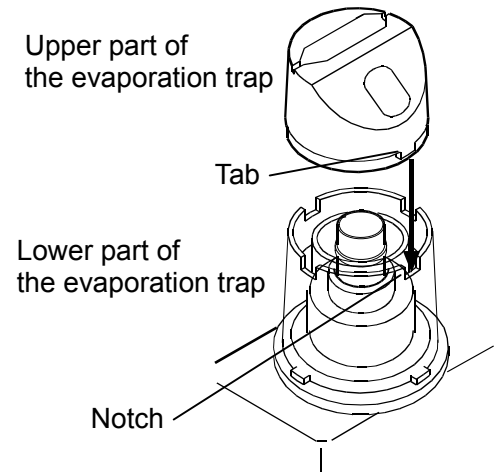

6. Adjust the direction of the evaporation trap so that the pipette insertion opening on the sloped surface is faced to allow easy operation.

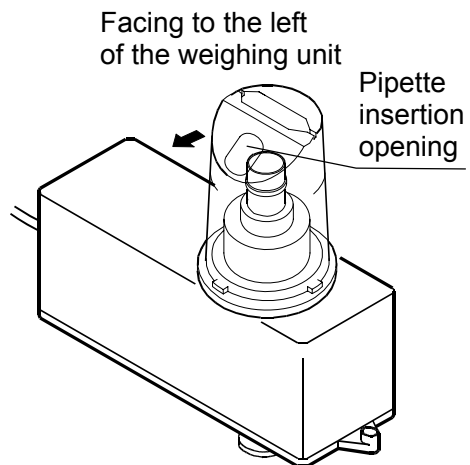
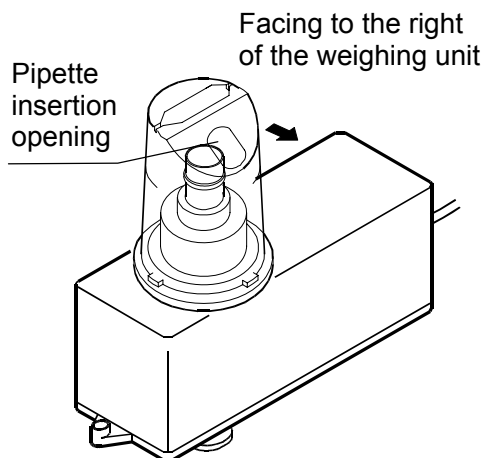

7. Install cap B on the evaporation trap. Remove cap A from the sloped surface.

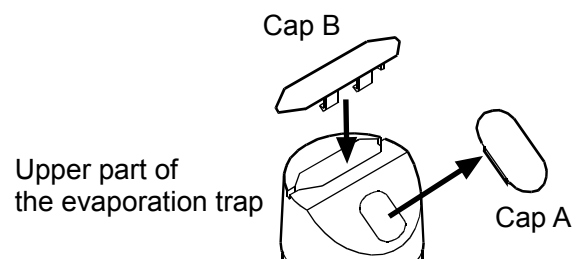

2-2 FX-300i-PT

1. Place the balance on a solid table.

For details on the installation site, refer to “3. PRECAUTIONS BEFORE USE”.

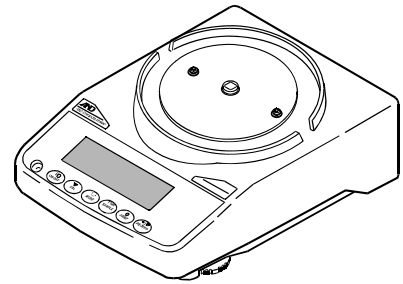

2. Install the fitting boss on the balance, then install the evaporation trap base on the fitting boss.

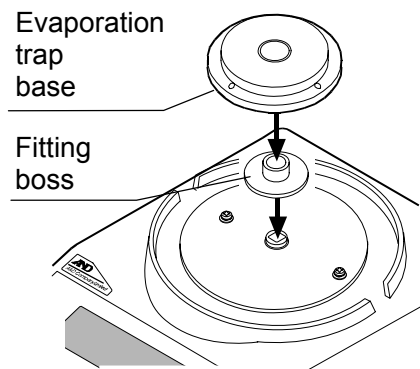

3. Install the sample cup holder (30 mL) on the base.

When the 30 mL sample cup is used:

Insert the sample cup into the holder.

When the 5 mL sample cup is used:

Insert the sample cup holder (5 mL) into the sample cup holder (30 mL), and then insert the sample cup

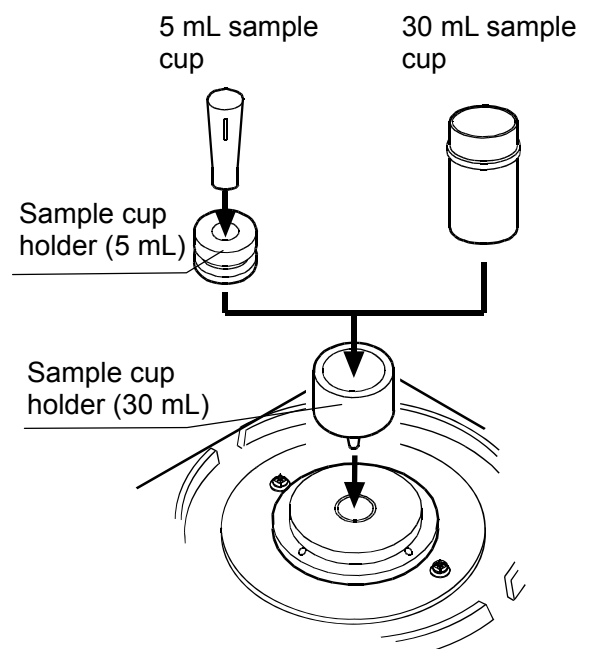

4. Install the lower part of the evaporation trap on the weighing unit, mating the tabs with the holes on the base.

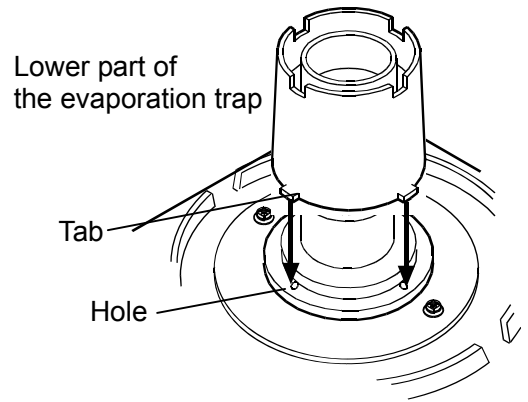

5. Attach the upper part of the evaporation trap to the lower part, mating the tab with the notch.

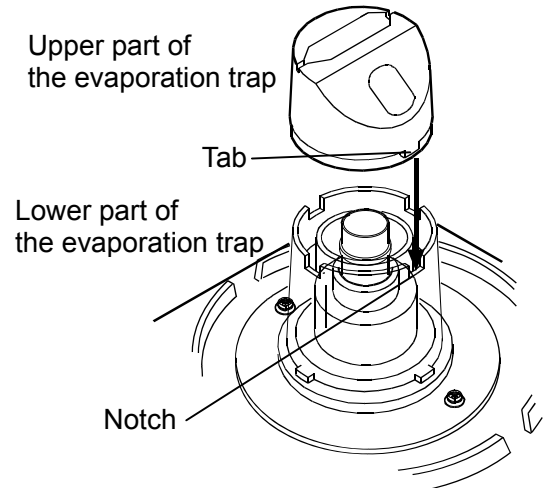

6. Adjust the direction of the evaporation trap so that the pipette insertion opening on the sloped surface is faced to allow an easy operation.

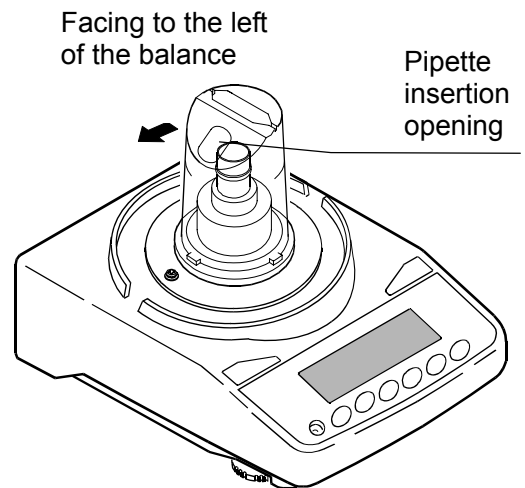
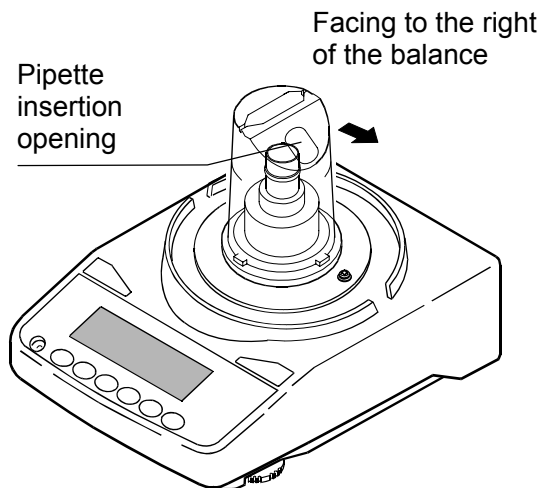

7. Install cap B on the evaporation trap. Remove cap A from the sloped surface.

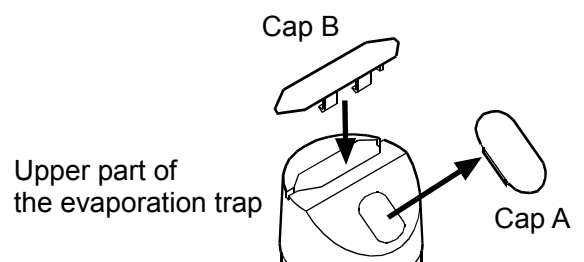

3. PRECAUTIONS BEFORE USE

To get the optimum performance from the balance and acquire accurate weighing data, note the following, especially when using the AD-4212B-PT / AD-4212A-PT with a minimum weighing value of 0.001 mg / 0.1 mg.

- Install the balance where the measurement environment is appropriate. The best operating temperature is 15°C to 30°C \pm 0.5°C with greater than 50% RH.
- Install the balance where it is not exposed to direct sunlight and it is not affected by air from heaters or air conditioners. Especially be careful when using the AD-4212B-PT. It responds even to very subtle air flow.
- Install the balance where it is free of dust.
- Install the balance away from equipment which produces magnetic fields.
- Install the balance in a stable place avoiding vibration and shock. Corners of rooms (close to pillars or walls) far from a passage way are best, as they are less prone to vibration.
- The weighing table should be solid and free from vibration, drafts and as level as possible.
- Level the balance by adjusting the leveling feet and confirm it using the bubble spirit level.
- Before use, warm up the balance for the appropriate duration, with nothing on the weighing pan.

AD-4212B-PT / AD-4212A-PT: one hour or more

FX-300*i*-PT: 30 minutes or more

When using the AD-4212B-PT with a minimum weighing value of 0.001 mg, keep the balance connected to power constantly.

- Calibrate the balance before use or after having moved it to another location. Use the accessory calibration weight for calibration. For details, refer to “7. CALIBRATING THE BALANCE”.

Caution

Do not install the balance where flammable or corrosive gas is present.

4. ANTI-STATIC TREATMENT

An anti-static treatment has been applied to the evaporation trap. Cleaning it with alcohol will reduce the effect of the treatment.

If the evaporation trap has acquired a static charge, apply an anti-static agent or use the optional AD-1683 DC static eliminator to remove the static electricity.

5. INSTALLING WinCT-Pipette

For detailed information on the WinCT-Pipette program, refer to "How to use WinCT-Pipette.pdf" in the WinCT-Pipette CD-ROM.

For installing WinCT-Pipette, refer to "Readme.txt" in the WinCT-Pipette CD-ROM.

System requirements

OS	Windows XP SP2 or later
CPU	Pentium or the equivalent, 1GHz or more recommended
RAM	512 MB or more recommended
Hard disk available space	Approximately 50 MB
Display	1024 x 768 or more recommended

6. CONNECTING A PC TO THE BALANCE

To make a connection between a PC and the balance, use the RS-232C cable or use both the RS-232C cable and the USB converter.

6-1 Connecting a PC

When a PC COM port is used

When using the COM port of a PC to make a connection to the balance, use the accessory RS-232C cable.

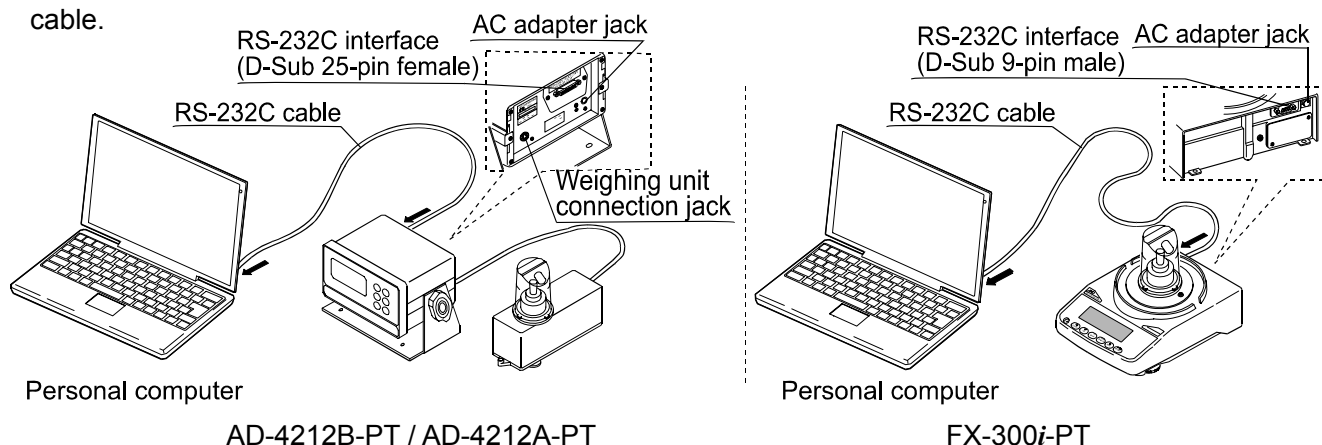

When a PC USB port is used

When using the USB port of a PC to make a connection to the balance, use both the accessory RS-232C cable and the USB converter (shipped in a separate package).

The USB converter, when connected to the USB port of a PC, adds a COM port to the PC. When connecting the USB converter to the USB port for the first time, installing a driver is required. (Some PCs may require a driver installation even when the USB port used is changed.)

The driver installation CD and the instruction manual are contained in the same package with the USB converter. For instructions on installation, read the manual.

After driver installation, connect the USB converter to the balance, using the RS-232C cable. Now a COM port is added and communications between the PC and the balance is enabled.

NOTE Although the USB converter is shipped in a separate package, it can be placed in the carrying case.

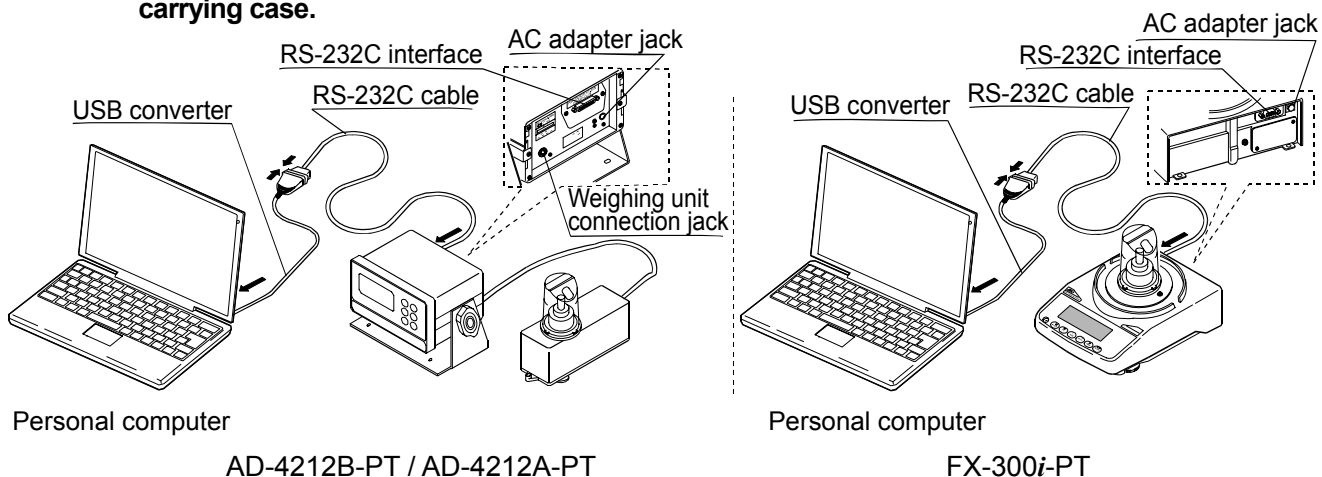

6-2 Checking COM Port Numbers

COM port numbers vary depending on the PC used. Use the Windows Device Manager to check COM port numbers.

NOTE When the USB converter is used, check the COM port number with the USB converter connected.

- 1 Click [Start], [Settings] and [Control Panel].
- 2 Double-click [System].
- 3 Click [Hardware] and [Device Manager].
- 4 Double-click [Port (COM & LPT)]. COM port numbers will be displayed.

When the USB converter is used, “ATEN USB to Serial Bridge (COMx)” appears. In the example below, the COM port number is 4.

The COM port for a personal computer is displayed as “Communications Port (COMx)”. In the example below, the personal computer has two COM ports. Therefore, two COM ports appear; “Communications Port (COM1)” and “Communications Port (COM2)”

Change the WinCT-Pipette COM port number to that of the COM port used.

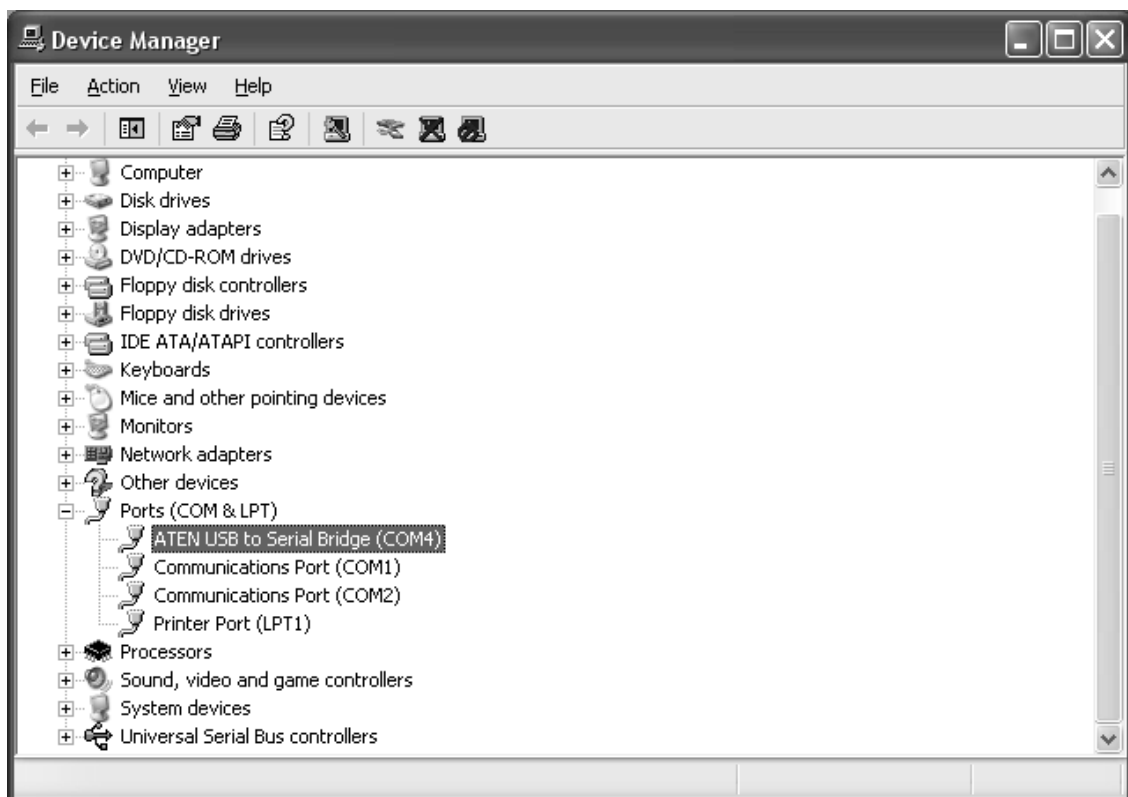

Checking COM port numbers in [Device Manager]

7. CALIBRATING THE BALANCE

For details on calibration, read the balance instruction manual in addition to this manual.

Before calibration, refer to “3. PRECAUTIONS BEFORE USE”. Especially when calibrating the AD-4212B-PT / AD-4212A-PT with a minimum weighing value of 0.01 mg / 0.1 mg, make sure that the installation environment is appropriate and the balance is warmed up for the appropriate duration.

7-1 AD-4212B-PT / AD-4212A-PT

1. Remove the sample cup, but leave two sample cup holders (5 mL and 30 mL) inside the evaporation trap, as shown to the right.

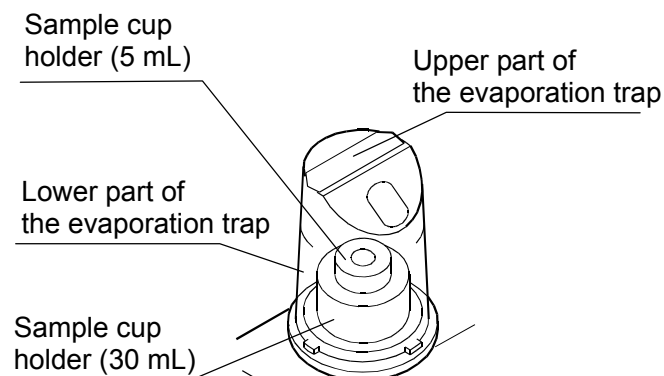

2. Press and hold the CAL key until **CALout** is displayed, then release the CAL key.

3. When **CAL 0** is displayed, press the PRINT key to enter the zero point.

4. After the zero point is entered, the calibration weight value **50** is displayed.

Remove the upper part of the evaporation trap while holding the lower part of the evaporation trap.

Place the accessory calibration weight on the sample cup holder (5 mL).

Attach the upper part of the evaporation trap to the lower part, mating the tab with the notch.

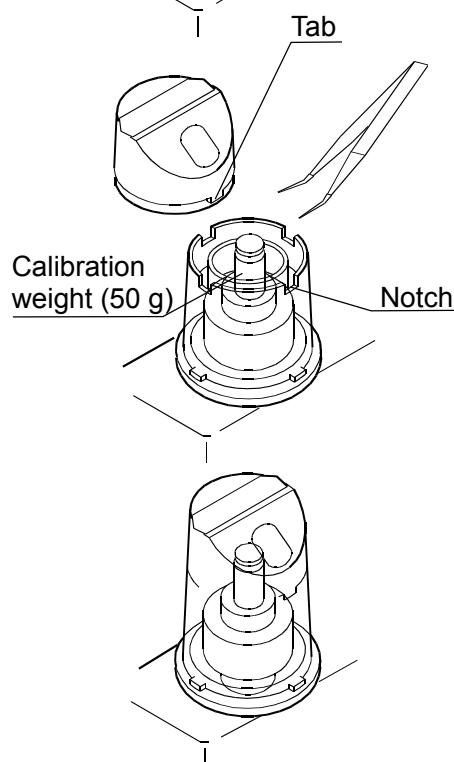

5. Press the PRINT key to calibrate the weighing capacity. When **End** is displayed, remove the calibration weight. The balance will return to the weighing mode.

6. Place the calibration weight on the sample cup holder (5 mL) to confirm that calibration has been completed successfully.

7-2 FX-300i-PT

1. Remove the 30 mL sample cup and leave only the sample cup holder (30 mL) inside the evaporation trap as shown to the right.

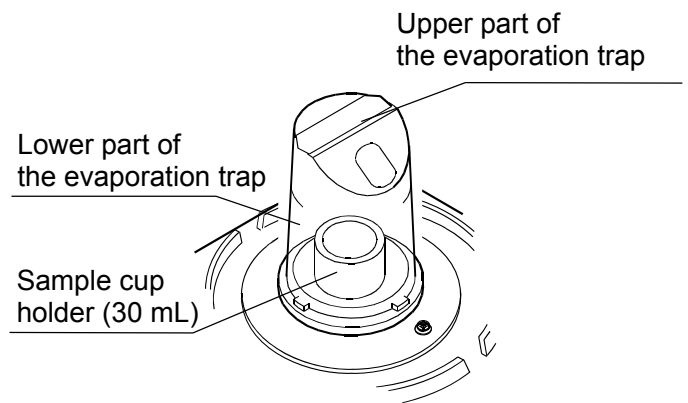

2. Press and hold the CAL key until **CALout** is displayed, then release the CAL key.
3. When **CAL 0** is displayed, press the PRINT key to enter the zero point.

4. After the zero point is entered, the calibration weight value **100** is displayed. Remove the evaporation trap by holding the lower part of the evaporation trap.

Place the accessory calibration weight on the sample cup holder (30 mL).

Attach the evaporation trap on the base, mating the tabs with the holes.

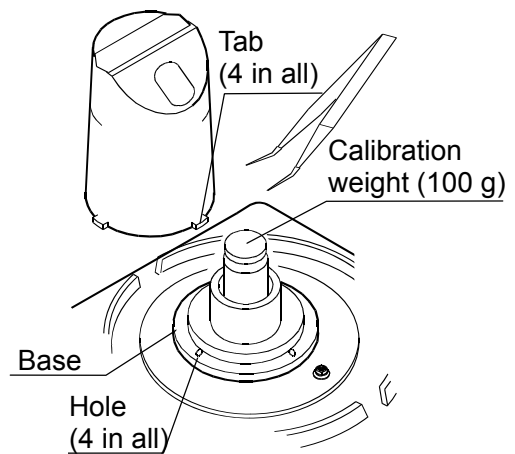

5. Press the PRINT key to calibrate the weighing capacity. When **End** is displayed, remove the calibration weight. The balance will return to the weighing mode.
6. Place the calibration weight on the sample cup holder (30 mL) to confirm that calibration has been completed successfully.

NOTE The evaporation trap can be used as a breeze break. Calibration can be performed, using the weighing pan and the breeze break provided as accessories.

8. PREPARATION BEFORE USE

The measurement environment recommended by ISO 8655 is as follows.

Temperature: Constant between 15°C and 30°C, changes in temperature $\pm 0.5^\circ\text{C}$.

Humidity: Greater than 50% RH

8-1 Filling the Evaporation Trap with Water

Remove the evaporation trap from the balance. Separate the upper and lower part of the evaporation trap. Pour water into the groove along the circumference of the inner wall of the lower part of the evaporation trap, using a wash bottle or a pipette, up to the center between the two lines on the evaporation trap.

NOTE When pouring water, use much care not to spill water around the fitting boss of the balance weighing pan.

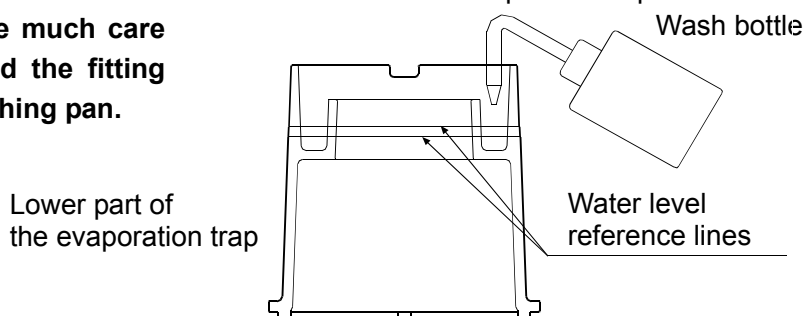

Attach the upper part of the evaporation trap to the lower part and place the evaporation trap on the balance or weighing unit.

It takes approximately 15 minutes for the humidity inside the evaporation trap to stabilize to about 85% RH. The time required for the humidity to stabilize varies depending on the measurement environment.

8-2 Preparing the Test Liquid

Pour distilled water into the test liquid cup.

Place the thermometer in the cup, using the clamp as shown below.

Leave as is to allow the temperature of the distilled water to stabilize. ISO 8655 recommends that the test liquid be acclimatized to the measurement environment for two hours or more.

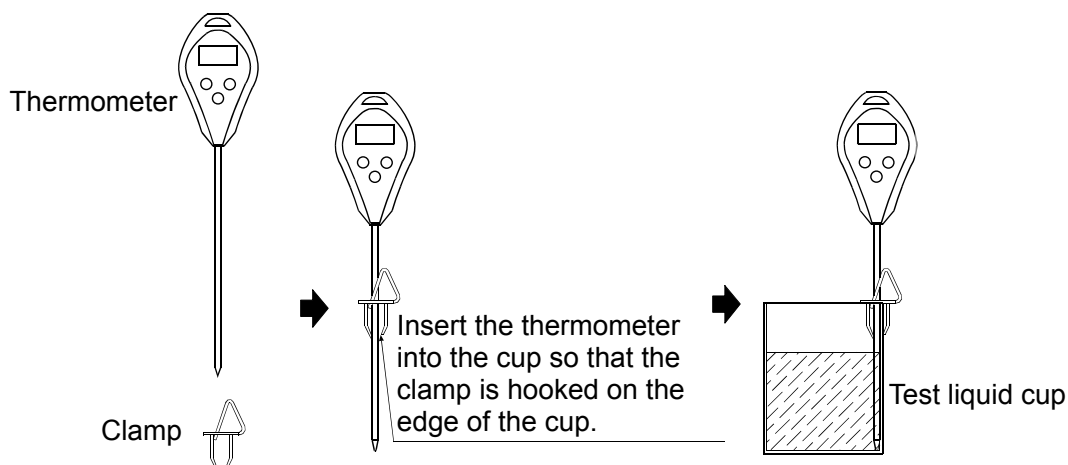

8-3 Preparing the Water-absorbent Sheet

To stabilize the evaporation amount of the dispensed test liquid from the sheet, moisten the sheet with the test liquid (approx. 600 μL for the 5-mL sample cup sheet, and approx. 4000 μL for the 30-mL sample cup sheet) before the test.

8-4 Using the Thermometer

Part names

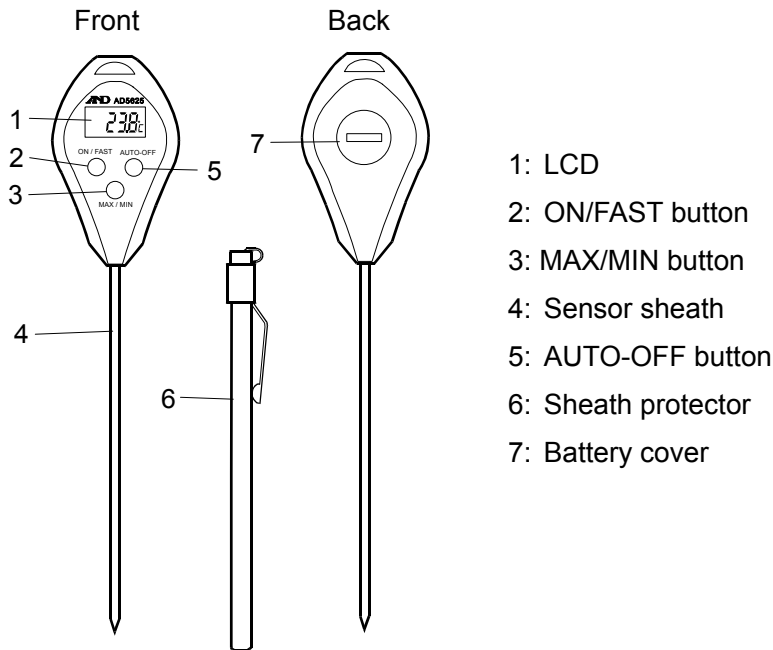

- 1: LCD
- 2: ON/FAST button
- 3: MAX/MIN button
- 4: Sensor sheath
- 5: AUTO-OFF button
- 6: Sheath protector
- 7: Battery cover

Before use

One LR-44 battery is provided with the thermometer. It is for testing the performance of the thermometer and may have a limited life. Before use, install the battery as described in “Replacing the battery” below.

Replacing the battery

When the LCD becomes blurred, replace the battery as follows.



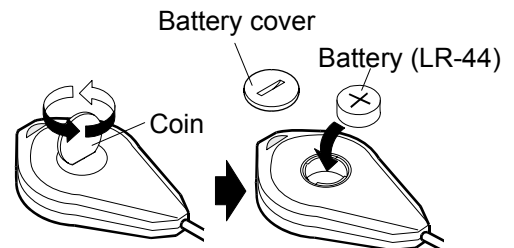

1. Place the thermometer on a table with the back up. Using a coin, rotate the battery cover anti-clockwise to remove it.
2. Remove the old battery.
3. Install a new battery, with the + side (flat side) facing up.
4. Using the coin, reattach the battery cover.

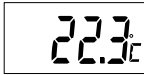

- NOTE**
- Be sure to face the + side up when installing a battery.
 - Use the specified battery only.
 - Do not disassemble, heat, short-circuit, dispose of in fire or attempt to recharge the battery. It may explode or leak and cause personal injury.
 - Keep the battery out of the reach of children. If swallowed, consult a physician immediately.
 - Follow the local regulations when disposing of a used battery.
 - To keep the thermometer watertight, do not damage the rubber ring or remove it from the battery compartment.

Displaying modes

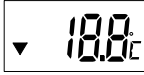
The thermometer has three display modes.

Displaying mode	Display example
<ul style="list-style-type: none"> • Current temperature mode Displays the current temperature. 	
<ul style="list-style-type: none"> • Max/Min temperature mode Displays the latest maximum and minimum temperatures that are automatically stored in the thermometer. 	Maximum temperature 
	Minimum temperature 
<ul style="list-style-type: none"> • Auto power-off mode Turns the power off automatically after six or seven minutes of no operation. 	

Measuring the temperature

Follow the procedure below to measure the water temperature.

1. Remove the sheath protector from the thermometer.
2. Press the ON/FAST button to turn the display on.
3. Insert the sensor sheath into the water.
4. The sampling interval is 10 seconds.
To speed this process, press and hold the ON/FAST button for a sampling interval of every 2 seconds.
5. As the thermometer responds to the water temperature, the displayed temperature changes, stabilizes and then displays the water temperature.

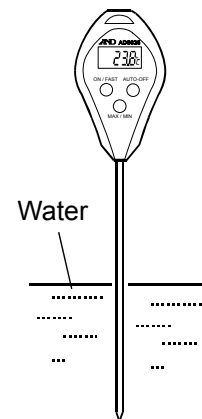

NOTE The thermometer detects the temperature at the tip of the sensor sheath. Do not expose parts of the thermometer other than the sensor sheath to the high or low temperature of the test liquid.

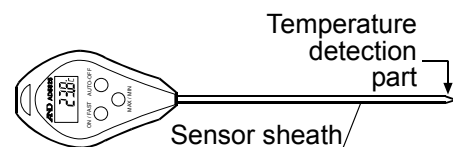

Recalling the maximum and minimum temperatures stored in memory

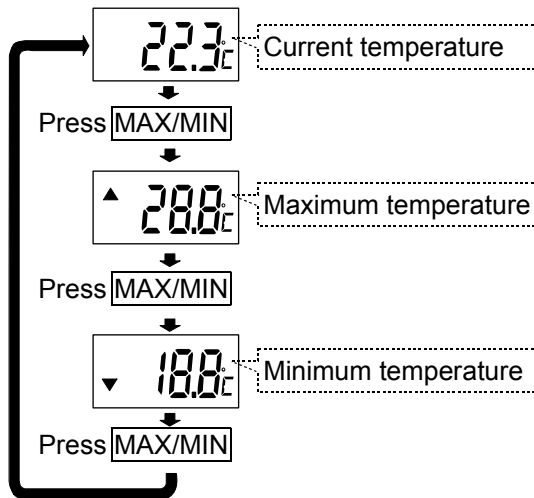

With the current temperature displayed, each pressing of the MAX/MIN button displays the maximum and minimum temperatures in turn.

To check the maximum and minimum temperature during measurement, reset the values in memory before measurement.

Resetting the maximum and minimum temperatures stored in memory

- Resetting the maximum temperature

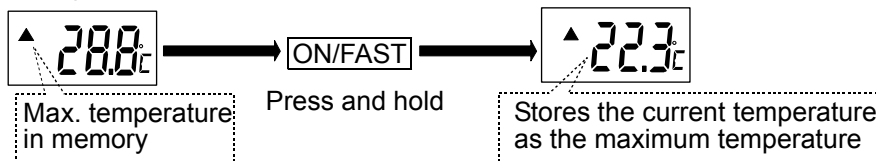

- Resetting the minimum temperature

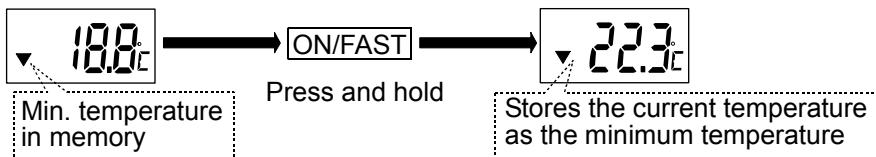

- Returning to the current temperature display

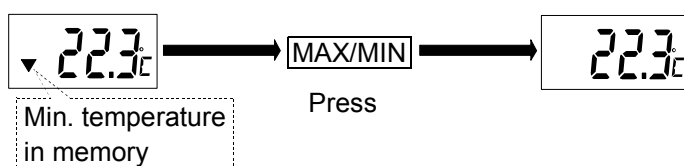

Turning the power off

1. Auto power-off mode

The thermometer has an auto power-off mode. To use this mode, press the AUTO-OFF button to display "AUTO". This indicates the thermometer is in the auto power-off mode. When no operation is performed for six or seven minutes, the power is turned off automatically.

2. Turning the power off

To turn the power off immediately, with "AUTO" displayed, press the AUTO-OFF button.

Cleaning the thermometer

For accurate temperature measurement, keep the temperature detection part clean.

Wash the thermometer softly in water. If contamination is hard to remove, clean the thermometer with a lint free cloth moistened with water and a mild detergent.

Specifications

Sensor	: Thermister
Measuring temperature range	: -50°C to 260°C
Display resolution	: 0.1°C
Accuracy	: ±1.0°C (0°C to 60°C), ±2.0°C (-20°C to 100°C), ±2.5°C (-50°C to 100°C), ±3.0°C (-50°C to 150°C), ±3.5°C (-50°C to 200°C), ±4.0°C (other)
Sampling interval	: Regular every 10 seconds FAST every 2 seconds
Water protection	: JIS IPX7 (Endures a 30-minute immersion in a water depth of 1 meter at room temperature)
Power source	: LR44 battery 1 piece
Battery life	: Approx. 1 year
Operating environment	: 0°C to 40°C, 75% RH or less, non-condensing (Excluding the sensor sheath)
Storage environment	: 0°C to 50°C, 75% RH or less, non-condensing
Sensor sheath dimensions	: φ2.80, approx. 110 mm
Dimensions/mass	: 176 x 40 x 16 mm, approx. 25 g (including the battery and sheath protector)
Standard accessory	: Sheath protector, battery

9. MEASUREMENT

9-1 Measuring Procedure

Using the predetermined pipette volume, perform the measurement the specified times.
ISO 8655 recommends ten measurements for each for the volumes described below.

- At the nominal volume of a fixed volume pipette
- At the following three points of an adjustable volume pipette
 1. 10% of the maximum volume or the lower limit of the adjustable volume range, whichever is greater.
 2. 50% of the maximum volume
 3. 100% of the maximum volume

NOTE Pipette volumes and number of measurements can be changed.

9-2 Judging the Results

WinCT-Pipette converts the mass values into volumetric values, compares these with the predetermined judgment standard and performs judgment whether the pipette will pass or fail.

- Judgment standard
 - The averaged value (exceeds / does not exceed) the specified maximum permissible error.
 - Repeatability (exceeds / does not exceed) the specified maximum permissible error.

9-3 Example Causes of Measurement Errors

Evaporation of the test liquid

Evaporation of the distilled water dispensed from the pipette into the sample cup can be a cause of measurement error.

To reduce errors caused by evaporation

- Be sure to use the evaporation trap. Using the evaporation trap, evaporation of the test liquid can be reduced to 0.05 mg per minute (0.05 μ L per minute).
- With the AD-4212B-PT / AD-4212A-PT, use the display lock function. For details, refer to “10-2 Display Lock Function”.

Water temperature and barometric pressure

Correctness of the Z factor, that is used to convert a mass value to a volumetric value, depends on the density by the water temperature.

The barometric pressure, even if changed in the range between 950 hPa and 1050 hPa, influences measurements only by 0.01%.

Water temperature, if changed by 5°C, influences measurements by 0.11%.

To reduce errors caused by water temperature

- Use the correct Z factor. To obtain the correct Z factor, measure the water temperature using the accessory thermometer and enter the value in WinCT-Pipette.
- For a stable water temperature, allow the temperature of the test liquid to acclimatize to the measurement environment for an appropriate duration of time (ISO 8655 recommends two hours or more) before measurement.

Vibration

Vibration yields unstable measurement values.

To reduce errors caused by vibration

- Install the balance in a stable place avoiding vibration and shock. Use a solid weighing table that is free from vibration.
- If the installation site is the second floor or higher, use the AD-1685 anti-vibration table.

Air flow

Air flow in the measurement environment yields unstable measurement values

To reduce errors caused by air flow

- Install the balance where it is not affected by heaters or air conditioners or where no drafts exist. Especially when using the AD-4212B-PT / AD-4212A-PT with a minimum weighing value of 0.01 mg / 0.1 mg, use much care in choosing an installation site or cover the weighing unit.

Operator

An operator's pipetting technique influences measurements.

To reduce errors caused by the pipetting technique

- Learn and use the correct pipette technique.

10. AD-4212B-PT / AD-4212A-PT

The AD-4212B-PT / AD-4212A-PT is designed exclusively as a pipette accuracy tester.

Although the performance as a balance is the same as the AD-4212B / AD-4212A production weighing unit, some of the specifications are different.

10-1 Factory Settings

When shipped, the factory settings of the AD-4212B-PT / AD-4212A-PT as a pipette accuracy tester are as follows.

Unit

- Weighing unit: mg
- Minimum weighing value for the AD-4212B-PT: 0.1 mg

Each time the SAMPLE key is pressed, the minimum weighing value changes as below:

0.1 mg → 0.01 mg → 0.001 mg → 1 mg → 0.1 mg ...

Press the SAMPLE key to switch the minimum weighing value as necessary.

For testing a liquid with a volume of less than 100 μL , the recommended minimum weighing value is 0.01 mg (0.01 μL). With a volume of less than 10 μL , 0.001 mg (0.001 μL).

Function table

Functions related to pipette accuracy testing are as follows.

Class	Item and Parameter	Description	
bRSFnc Environment Display	[ond Condition	0	Fast weighing speed, sensitive value
		1	
		2	
	[rc Zero tracking	0	OFF
		1	Normal
		2	Strong
		3	Very strong
	SPd Display refresh rate	0	5 times/second
		1	10 times/second
	PLoc Display lock function	0	OFF
1		ON	
[P Fnc Comparator	[P Comparator mode	0	No comparison
		1	Comparison, excluding "near zero" when stable or overloaded
		2	Comparison, including "near zero" when stable or overloaded
		3	Continuous comparison, excluding "near zero"
		4	Continuous comparison, including "near zero"

- Factory setting

10-2 Display Lock Function

To use this function, set “Display lock function ($P_{L O C}$)” to “ON (I)”.

Why use this function

This function is used to compensate time-elapsing errors caused by evaporation.

Even when the evaporation trap is used, an evaporation of 0.05 mg per minute (0.05 μ L per minute) will occur. This evaporation influences the measurement, particularly when the volume of the test liquid is small. For such a situation, the display lock function is useful.

How this function works

After the test liquid is dispensed from the pipette, measurement starts. When the mass value is stable, data is averaged. After a certain period of time, the averaged value is locked in the display.

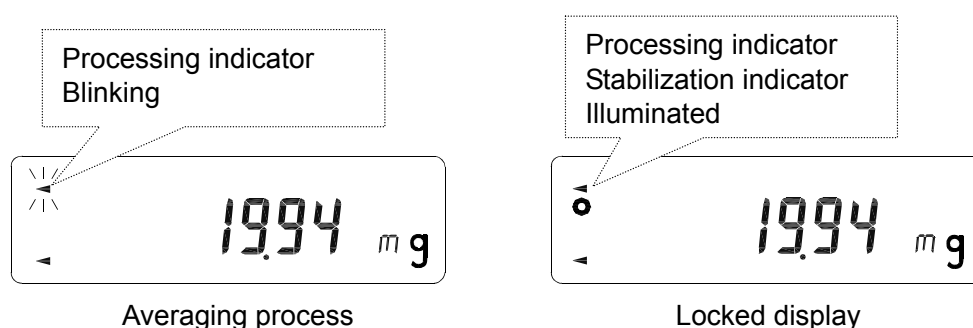

NOTE The RE-ZERO operation unlocks the display.

10-3 Auto Print Mode

In the balance function setting of “Data output (d_{out})”, when “Data output mode ($P_{r t}$)” is set to “Auto print mode A (I)”, the mass value will be transmitted to WinCT-Pipette automatically once the mass value of the dispensed test liquid becomes stable.

11. TROUBLESHOOTING

- Displayed values are unstable.

The AD-4212B-PT / AD-4212A-PT has a minimum weighing value of 0.01 mg / 0.1 mg and is influenced by the measurement environment.

Measures to take

- Use the accessory breeze break.
 - Referring to “3. PRECAUTIONS BEFORE USE”, check the measurement environment for sources of drafts, vibration and static electricity.
 - The AD-4212B-PT with a minimum weighing value of 0.01 mg is prone to low-frequency vibration such as shaking buildings. Particularly, earthquake, wind and changes in the barometric pressure influence measurement. To avoid vibration, install the balance on the first floor, in the corners of rooms (close to pillars or walls) far from a passage way.
 - Use the AD-1685 anti-vibration table.
 - Use the optional AD-1683 DC static eliminator or use the optional AD-1684 electrostatic field meter if the cause of the unstable values may be due to static charges.
- Repeatability of the measurement values is low. The measurement values are not correct.

Measures to take

- Referring to “3. PRECAUTIONS BEFORE USE”, check the measurement environment. Using the accessory calibration weight, measure the balance repeatability and check the balance performance.
 - Referring to “9-3 Example Causes of Measurement Errors”, check the measurement environment for causes of errors.
- Balance error displays
Refer to the balance instruction manual.

12. SPECIFICATIONS

	AD-4212B-PT	AD-4212A-PT	FX-300i-PT
Weighing capacity *1	110 g / 31 g / 5.1 g *2	110 g	320 g
Minimum weighing value	0.1 mg / 0.01 mg / 0.001 mg	0.1 mg	1 mg
Linearity	±0.2 mg / ±0.05 mg / ±0.005 mg	±0.3 mg	±2 mg
Repeatability (Standard deviation)	0.1 mg / 0.05 mg / 0.015 mg	0.15 mg	1 mg
Dimensions	Weighing unit: 80 (W) x 230 (D) x 200 (H) mm Display (with a stand): 237 (W) x 150 (D) x 155 (H) mm		193 (W) x 262.5 (D) x 190 (H) mm
Standard accessories *3	<ul style="list-style-type: none"> • Instruction manual • Balance including the weighing pan unit, breeze break, AC adapter and AC adapter ID label • Calibration weight with a pair of tweezers • Evaporation trap • Sample cup (30 mL x 2 / 5 mL x 2) *4 • Sample cup holder (30 mL / 5 mL) • Thermometer • USB communications kit (USB converter, RS-232C cable, Instruction manual) • WinCT-Pipette (CD-ROM) • Carrying case with a shoulder belt and a key 		
AC adapter	Please confirm that the AC adapter type is correct for your local voltage and power receptacle type.		
Pr consumption	Approx. 11VA (supplied to the AC adapter)		
Carrying case dimensions	470 (W) x 150 (D) x 355 (H) mm		
Mass (With all accessories in a case)	Approx. 7.6 kg	Approx. 7.2 kg	Approx. 6.4 kg

***1** When the balance weighing pan is used.

***2** The AD-4212B-PT is equipped with a smart range function. When the minimum weighing value is set to 0.001 mg and the mass value exceeds 5.1 g, the minimum weighing value will switch to 0.01 mg, and when the mass value exceeds 31 g, the minimum weighing value will switch to 0.1 mg automatically. Even under this circumstance, pressing the RE-ZERO key tares the value and weighing with the minimum weighing value of 0.001 mg is available from that point up to 5.1 g.

***3** The standard accessories for the AD-4212B-PT / AD-4212A-PT / FX-300i-PT are different from those for the AD-4212B / AD-4212A / FX-300i.

***4** Sample cups and water-absorbent sheets are available separately for purchase as options.

12-1 Options

Name and components	Model
5-mL sample cup (with a water-absorbent sheet installed) 5-mL sample cup 5 pcs. Lid for 5-mL sample cup 5 pcs Water-absorbent sheet for 5-mL sample cup 5 pcs (The sheet is installed in the cup before shipping.)	AX-PT-01
30-mL sample cup (with a water-absorbent sheet installed) 30-mL sample cup 5 pcs. Lid for 30-mL sample cup 5 pcs Water-absorbent sheet for 30-mL sample cup 5 pcs (The sheet is installed in the cup before shipping.)	AX-PT-02
Water-absorbent sheet for the 5-mL sample cup 5 pcs	AX-PT-03
Water-absorbent sheet for the 30-mL sample cup 5 pcs	AX-PT-04

13.APPENDIX

The table below lists the relation between the ISO 8655 requirements and the PT series pipette accuracy testers.

Pipette nominal volume *5	ISO 8655 requirements				Balance minimum weighing value
	Maximum permissible error				
	Accuracy		Repeatability		
(μL)	$\pm\%$	$\pm\mu\text{L}$	$\%$	μL	mg
1	5.0	0.05	5	0.05	0.001
2	4.0	0.08	2	0.04	
5	2.5	0.125	1.5	0.075	
10	1.2	0.12	0.8	0.08	
20	1.0	0.2	0.5	0.1	0.01
50	1.0	0.5	0.4	0.2	
100	0.8	0.8	0.3	0.3	
200	0.8	1.6	0.3	0.6	0.1
500	0.8	4.0	0.3	1.5	
1000	0.8	8.0	0.3	3.0	
2000	0.8	16	0.3	6.0	
5000	0.8	40	0.3	15	
10000	0.6	60	0.3	30	
Daily inspection, simplified verification *7					

Pipette accuracy tester corresponding to the requirements

 The AD-4212B-PT***6**

 The AD-4212A-PT

 FX-300i-PT

***5** The maximum volume selectable for adjustable volume pipettes

***6** The AD-4212B-PT can be used for the pipette volume range from 1 μL to 10000 μL .

***7** The minimum weighing value, 1 mg, approximately corresponds to 1 μL . If a pipette volume is 1000 μL , a test can be performed with a resolution of 0.1%. If 200 μL , 0.5%.

NOTE Pipette accuracy testing is performed using a high-resolution valance. Make sure that the measurement environment is free from vibration, drafts and air from air conditioners. For details, refer to “3. PRECAUTIONS BEFORE USE”.