



More information on the website
radwag.com/en/info,w1,RQW

AS 82/220.R2 PLUS Analytical Balance



Functions



Autotest



Dosing



Percent Weighing



Totalizing



Parts counting



Peak hold



Newton unit measurement



Statistics



Checkweighing



Under-pan weighing



GLP Procedures



Animal weighing



Density determination

Datasheet

Metrological parameters

Maximum capacity [Max]	82 / 220 g
Minimum load	1 mg
Readability [d]	0,01 / 0,1 mg
Tare range	-220 g
Verification scale interval [e]	1 mg
Standard repeatability [5% Max]	0,012 mg

Metrological parameters	
Standard repeatability [Max]	0,08 mg
Permissible repeatability [5% Max]	0,02 mg
Permissible repeatability [Max]	0,1 mg
Linearity	±0,05/0,2 mg
Stabilization time	2 s
Adjustment	internal (automatic)
OIML Class	I
Standard minimum weight (USP)	24 mg
Standard minimum weight (U=1%, k=2)	2,4 mg
Protection class	IP 43
Physical parameters	
Levelling system	manual
Display	LCD (backlit)
Weighing pan dimensions	ø90 + ø85 (option) mm
Packaging dimensions	495×400×515 mm
Net weight	7,3 kg
Gross weight	9,3 kg
Communication interface	
Communication interface	2×RS232, 2×USB-A (interchangeable), USB-B, Wi-Fi (option)
Electrical parameters	
Power supply	100 ÷ 240 V AC 50 / 60 Hz
Environmental conditions	
Operating temperature	+10 ÷ +40 °C

Repeatability is expressed as a standard deviation from 10 weighing cycles.

Stabilization time depends on the ambient conditions and the dynamics of weighing pan loading; specified for FAST profile.

* Wi-Fi® is a registered trademark of Wi-Fi® Alliance.



Accessories

Receipt Printer
 Granite Antivibration Tables
 Holders for laboratory flasks
 Barcode scanners
 Cigarette lighter receptacle power supply cables
 Power Adapters
 USB cable (scale - printer)
 Professional weighing table
 Holders for test tubes and filters

Workstation for Pipettes Calibration
 Displays
 Protective cover for balances
 Antistatic ionizer
 AP2-1 Current Loop Unit
 RPANEL BOX
 RS 232, RS 485 cables
 Under-Pan Weighing Rack
 RS 232 cables (scale - EPSON printer)

Software

RAD-KEY
 R Panel

LabVIEW Driver
 RADWAG Connect

Device dimensions

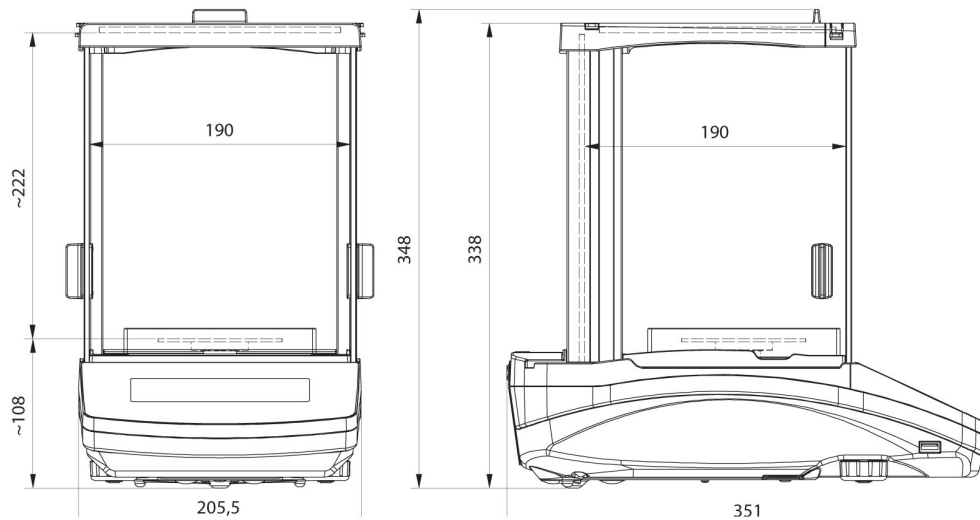

AS R2, d = 0.01 mg

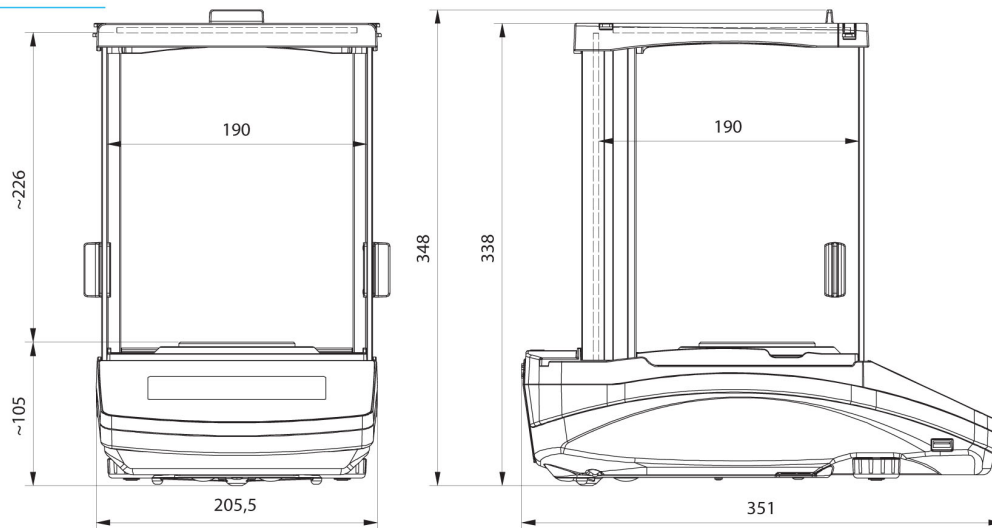

AS R2, AS R1 d = 0.1 mg