



*Professional Weighing
Equipment*

DCT SERIES

DUAL COUNTING SCALE



Operating Manual

Declaration of Conformity

Declaration of conformity for apparatus with CE mark

We hereby declare that the product to which this declaration refers conforms to the following standards.

Electronic scale: DCT Dual Counting Scale

Available Models:

DCT-50
DCT-100

Mark applied	EU Directive	Standards
	2004/108/EC	EN 61326-1: 2006

Date: 14. 11. 2012

Signature:



Boon Lim, R & D Manager

LW Measurements LLC, 3510 Industrial Drive, Unit H Santa Rosa, CA 95403

Identification

Customer Service

USA

LW Measurements LLC, 3510 Industrial Drive,
Unit H Santa Rosa, CA 95403
USA

Tel: (707) 542-2185
FAX: (707) 542-3285

EUROPE

LW Measurements Europe Ltd
Chalkwell Park House 700 London Road
Westcliff-on-Sea Essex SS0 9HQ
United Kingdom

Tel: 01702-476700
Fax: 01702-477380

ASIA

LW Measurements PTY Ltd
Block 1004, Toa Payoh North
#03-16 Singapore 318995

Tel: (65) 6458 3438
HP: (65) 8119 3401

<http://www.lwmeasurements.com>

Refer to our website for information about local customer service centers and details of their addresses.

Introduction

What you should know about these Operating Instructions:

Tree® Professional Weighing Equipment products are simple to operate.

Nevertheless, you should read through these operating instructions in their entirety, so that you can make optimum use of the full potential and the diverse possibilities of the weighing machine in your daily work.

These operating instructions contain guidance in the form of pictograms and keyboard diagrams, which should help you in finding the required information:

For the labelling of potential hazards and advice, please see Safety below.

Contents

Section	Heading
1	Safety
	1.1 Representation and symbols 1.2 Safety recommendations
2	Your weighing machine
	2.1 Construction and functions 2.1.1 Construction of the weighing machine 2.1.2 Functions of the weighing machine 2.2 Application, conformity 2.2.1 Correct use of the weighing machine 2.2.2 Conformity 2.3 Data and parameters 2.3.1 Technical data
3	Getting started with your weighing machine
	3.1 Unpacking the equipment 3.2 Scope of delivery 3.3 Assembling your weighing machine 3.4 Choice of a suitable location 3.5 Checking the mains voltage 3.6 Leveling the weighing machine 3.7 Calibration of the weighing machine
4	Working with the application menu using the intelligent keypad
	4.1 Display messages and key functions 4.1.1 Display messages 4.1.2 Key functions 4.2 Program options 4.2.1 Pieces counting 4.2.1.1 Counting with a known sample weight 4.2.1.2 Counting without a known sample weight 4.2.2 Select a pre-stored unit weight 4.2.3 High/Low Check Weighing when Counting
5	Calibration - using an external calibration weight
6	Maintenance and service
7	Transport and storage
	7.1 Transportation and shipping 7.2 Storage

1 Safety

1.1 Representations and symbols

Important instructions, which involve safety, are highlighted with the appropriate mark:



1.2 Safety recommendations

When using the weighing equipment in surroundings with increased safety requirements, the corresponding regulations must be observed.

The weighing machine may only be used with the power adapter supplied exclusively for use with the weighing machine.

Before inserting the power adapter, the user must ensure that the operating voltage stated on the power adapter agrees with the mains voltage.

If not, please contact Customer Service at the address above.

If the power adapter or its cable is damaged, the weighing machine must immediately be disconnected from the electricity supply (pull out the power adapter).

The weighing machine may only be operated from mains electricity supply with a power adapter which is in perfect condition.

If there should be any reason to believe that it is no longer possible to operate the weighing machine without danger, the weighing machine is to be immediately unplugged from the electricity supply (pull out power adapter) and secured against inadvertent operation.

In carrying out maintenance work, it is essential to follow the recommendations in Chapter 6 Maintenance and service.

The weighing machine must not be operated in an area subject to explosion risks.

Care must be taken when weighing liquids to ensure that no liquid is spilt into the inside of the weighing machine or into connections on the rear of the equipment or the power adapter. If liquid is spilt on the weighing machine, it must immediately be unplugged from the mains electricity supply (pull out power adapter).

The weighing machine may only be operated again after it has first been re-checked by a service technician.

These operating instructions must be read by each operator of the equipment and must be available at the workplace at all times.

2 Your weighing machine

2.1 Construction and functions

2.1.1 Construction of the weighing machine

The weighing machine consists of the weighing machine body (1), the scale-pan (2), the adapter (3) and this operating manual.

Figure 2.1 Your weighing machine

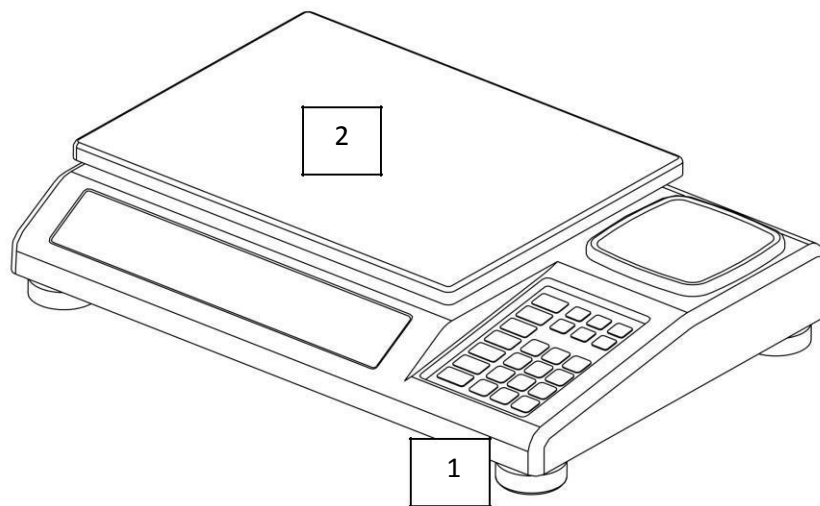

2.1.2 Functions of the weighing machine

The DCT Series are high-quality electronic precision weighing machines designed to function as counting scales with the following specifications.

Specifications:

Model number	Capacity	Division	Weighing pan Size
DCT-50	50lb/2lb	0.001 lb/0.00005lb	345x260/114x114mm
DCT-100	100lb/4lb	0.002lb/0.0001lb	345x260/114x114mm
Package (Standard carton)	540x380x170mm		
Package (Master carton)	2 Units in one box: 555x395x370mm		
Operating Temperature	0°C - 40°C (32-104°F)		
Power source	Rechargeable batteries or AC/DC Adapter 10-12V/500mA		

The built-in versatile weighing programs allow you to use the DCT-Series weighing machines not only for accurate weighing but also for components counting.

FEATURES

- Auto zero tracking
- Intelligent applications: weight unit conversion, parts counting
- Low battery indication
- Large LED
- Large heavy gauge stainless steel square pan
- Second smaller heavy gauge stainless steel pan
- Stability indication
- Auto calibration
- Selectable auto back light
- Unit switching kg or lb
- Variable kg or lb reference weight calibration software
- 1.3 million internal resolution
- Selectable display resolutions, 50000d, 25000d, 10000d, 6000d, 5000d and etc.
- 24 bit A/D processor
- Highest quality sensor used
- Die cast aluminum sub-support bottom sensor support and steel thread footing
- Able to enter unit piece weight on numeric keypad
- Able to enter tare weight on numeric keypad
- Print out change from kg to g

Figure 2.2 Details of your weighing machine

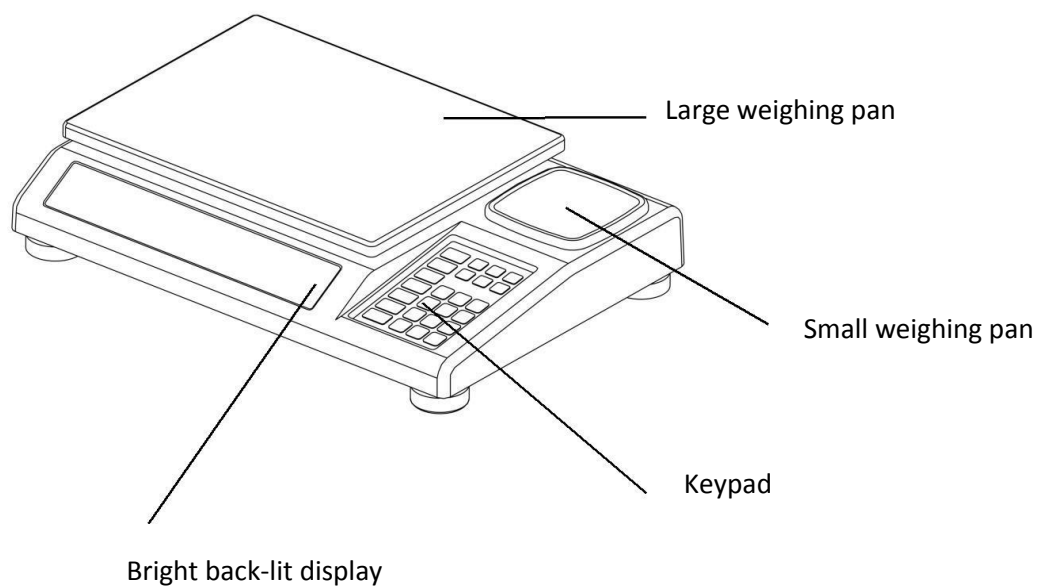

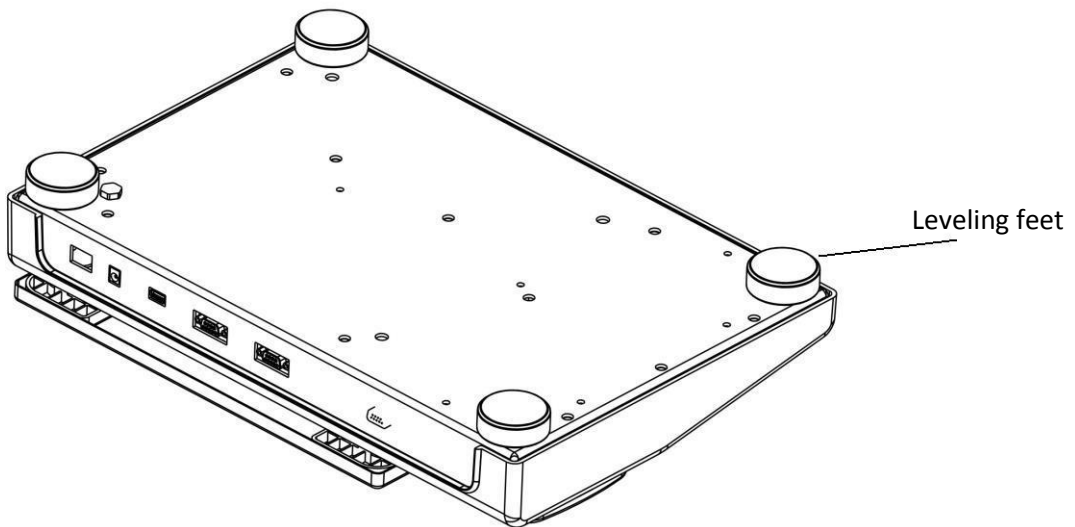
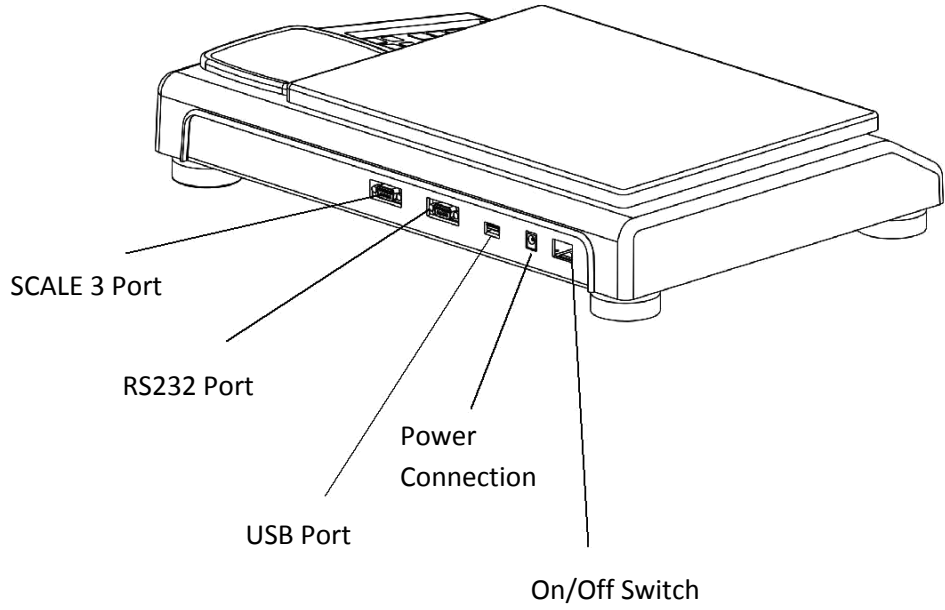
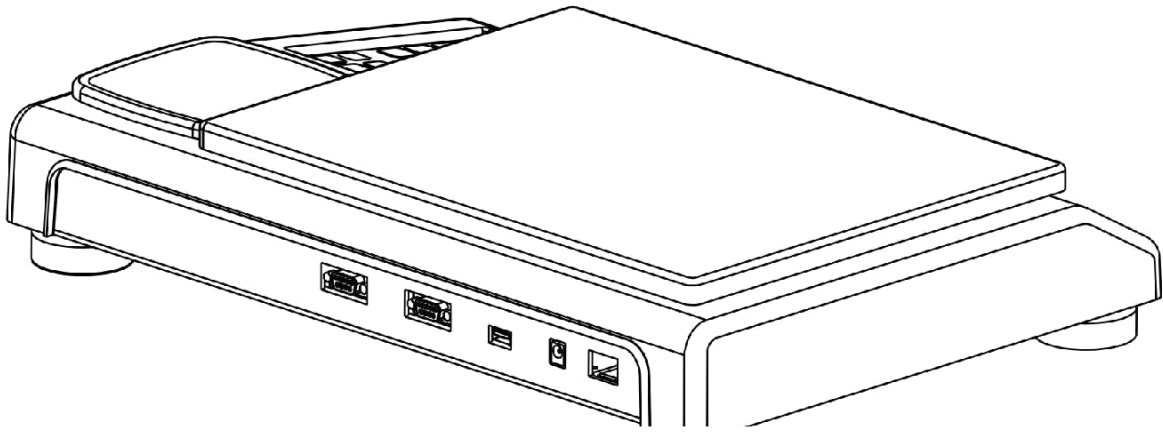

2.2 Application, conformity

2.2.1 Correct use of the weighing machine

The weighing machine may only be used for the weighing of solid-materials and of liquids filled into secure containers.

The maximum allowable load of the weighing machine must never be exceeded; otherwise the weighing machine may be damaged.

In using the weighing machine in combination with other appliances as well as with appliances produced by other manufacturers, the appropriate regulations for the safe use of the relevant attachments and their application in accordance with instructions must be observed.

2.2.2 Conformity

The weighing machine has been manufactured and tested in accordance with the standards and recommendations set out in the declaration of conformity.

The power adapter produced for the operation of the weighing machine and intended exclusively for this application complies with the appropriate electrical protection class.

2.3 Data and parameters

2.3.1 Technical data

The following applies to all DCT series weighing machines

Power supply:

- . Input: 110 or 230V AC (+/-15-20%); 50 to 60Hz
- . Output: 10-12v DC 500mA

Allowable ambient conditions

Temperature: 0°C - 40°C

Relative humidity: 25% - 85%, non-condensing

If you have any questions on the technical data or require detailed technical information on your balance, please contact your technical representative.

3 Getting started with your weighing machine

3.1 Unpacking the equipment

The machine is delivered in an environmentally-friendly carton, specifically developed for this precision instrument, which provides optimum protection for the balance during transportation.

We suggest that you retain the original packaging in order to avoid transportation damage if re-shipping or transporting the balance and to allow the unit to be stored in the best conditions if it is out of operation for an extended period.

In order to avoid damage, attention must be given to the following points when unpacking the balance:

Unpack the weighing machine carefully. It is a precision instrument.

When outside temperatures are very low, the balance should first be stored for some hours in the unopened transport package in a dry room at normal temperature, so that no condensation settles on the unit when unpacking.

Check the weighing machine immediately after unpacking for externally visible damage. If you should find transport damage, please inform your service representative immediately.

If the unit is not to be used immediately after purchase but only at a later time, it should be stored in a dry place where fluctuations in temperature are as small as possible (see Chapter 7 .Transport, storage.).

Read through these operating instructions, even if you already have prior experience with weighing equipment, before you work with the unit and pay attention to the Safety recommendations (see Chapter 1 .Safety).

3.2 Scope of delivery

Inspect delivery for completeness immediately on unpacking all components.

Checklist for complete delivery

	Component delivered present yes / no
Weighing unit body	
Weighing pan(s)	
Power adapter	
Operating manual	

3.3 Assembling your weighing machine

The weighing machine is delivered in partly dismantled condition. Assemble the individual components in the following sequence:

- Place the unit holder in position and add the weighing pan
- Insert the power adapter cable plug into the socket at the rear of the balance.

3.4 Choice of a suitable location

The environment in which your weighing machine is used is very important. Air movement, temperature changes, vibrations, direct sunlight, etc. all influence the performance of high precision weighing machines. Therefore, place your weighing machine on a solid, sturdy surface that is free of air currents, vibration and not in direct sunlight. The surface should not be magnetic and should be located away from doors, windows, heaters, air conditioners and fans.

To summarize:

- Put the weighing machine on a solid, firm and preferably vibration-proof, horizontal base
- Make sure that the weighing machine cannot be shaken or knocked over
- Protect from direct solar radiation
- Avoid drafts and excessive temperature fluctuations

3.5 Checking the mains voltage

The following Safety recommendations must be observed when connecting the balance to the mains:



The balance may only be operated with the power adapter supplied.

Check before connecting the power adapter to the mains supply, that the operating voltage stated on the power adapter agrees with the local mains voltage.

If the operating voltage is not the same as the mains voltage, the power adapter must on no account be connected to the mains supply. Contact customer service.

3.6 Leveling the weighing machine

To function properly, the balance must be precisely horizontal. The balance is fitted with one bubble level and adjustable feet for level-control, with the aid of which it is possible to compensate for small height differences and / or any unevenness in the surface on which the balance is positioned.

The screw feet must be adjusted so that the air bubble is precisely in the center of the sight glass of the bubble level (see Fig. 1)

Place the scale horizontally and keep the bubble inside the bubble level aligned with the red circle (See Fig.1). In order to get exact measurements, the balance must again be carefully leveled after each relocation.

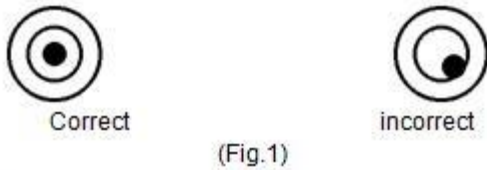

Fig. 1 Correct leveling with the aid of the bubble level and adjusting feet.

3.7 Calibration of the weighing machine

Since the Earth's gravity is not the same everywhere, each balance must be adjusted to compensate for the gravity differences at each location in accordance with the underlying physical weighing principles. This adjustment process, known as calibration and must be carried out on initial installation and after each subsequent relocation.

In order to ensure exact measurements, it is recommended that the balance should be calibrated regularly using a known external calibration weight (see Section 5 below).

4 Working with the application menu using the Key-Pad

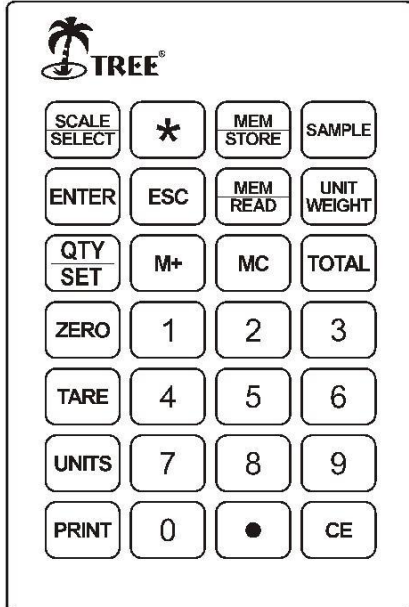

4.1 Display messages and key functions

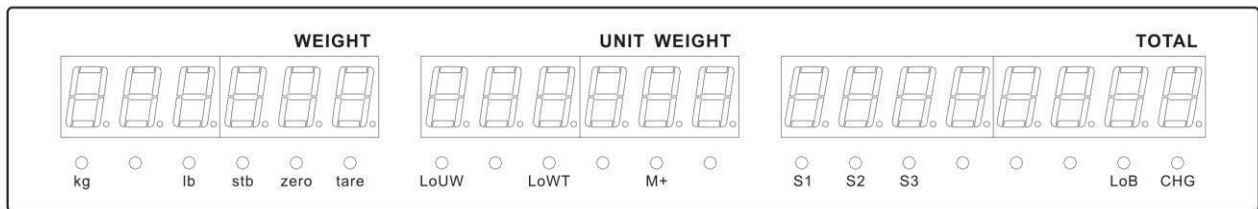

4.1.1 Display messages

1. Kg: unit of measure
2. lb: unit of measure
3. stb: stable indication
4. zero: ZERO INDICATOR turns on when scale is in Zero position
5. tare: TARE INDICATOR turns on when this function is used
6. LoUW: turns on when sample unit weight is not heavy enough for accurate counting
7. LoWT: turns on when sample number is not enough for accurate counting
8. M+: is used when accumulating the counts data; this data is memorized by pressing this key and can be accumulated up to 99 times.

9. S1: SCALE 1 working state
10. S2: SCALE 2 working state
11. S3: SCALE 3 working state
12. LoB: low voltage, please charge battery
13. CHG: charged state, red LED lights up when charging, when the battery is fully charged, Red and Green LED lights flash alternately.

4.1.2 Key functions

1. SCALE/SELECT: Press this button to select available counting scale among scale 1, scale 2, and scale 3. You can only choose to use one of them at a time.
 - SCALE 1: Main counting scale, the bigger platform
 - SCALE 2: Smaller counting scale offers more accuracy
 - SCALE 3: Extra connection platform. When we get the sample weight from SCALE 2, we can use this platform to count more samples.Operation way: press < Scale/ select > key, WEIGHT line will show flashed [SCALE 1], press < Scale/ select > key to select then press <Enter> key to confirm .
2. UNIT key changes the weight units between kg and lb
3. ZERO key sets display to zero or subtract the container weight. The zero range is <10% of full capacity. ZERO LED indicator will illuminate when you active the ZERO function.
4. TARE key subtracts the weight of a container placed on the weighing platform. The tare range is <100% full capacity. Press the TARE key to enable the Auto-Tare function, the TARE LED indicator will illuminate when you activate the TARE function.
 - Operation way 1 : turn on the scale and wait for ZERO mode then place container press<TARE>key , WEIGHT line will show flashed 0.0000, TARE LED indicator will light up when you activate it.
 - Operation way 2: (new version function) turn on the scale and wait for ZERO mode then place container press<TARE>key, WEIGHT line will show -X.XXX, ZERO LED indicator will light up when you activate it.
5. PRINTER key is used to transmit data to a printer, computer, or other device.
 - It should be connect to PC or printer by USB or RS232.
6. ENTER key has the same function as it would on a computer keyboard.
7. MEM/STORE key is the SAMPLE WEIGHT MEMORY KEY. Press this key to memorize sample weight, scale can memorize up to 16 different sample weights.
 - eg: if you want to store sample weigh 0.22047 (1/1000 lb) at place 7, please operate as below:
 - press [MEM/STORE], WEIGHT line will show flashed [01], press [*] to select storage place 7 then press ENTER to confirm.

8. MEM/READ key is the SAMPLE WEIGHT READ KEY. Press this key to recall the memorized sample weight, if more than one sample weight is memorized continue to press this key until the correct sample weight is selected.
Operation way: input unit weight storage place by number key then press [MEM/READ] key to catch unit weight.

9. [M+] MEMORY KEY is used when accumulating the counting data. This data is memorized by pressing this key and can be accumulated up to 99 times.
Operation way: place weight then press [M+], WEIGHT line will show how many times =XX=, UNIT WEIGHT line shows flashed [Add], press <Enter> key to confirm it and back to counting mode. M+ LED indicator will light up when you activate it. press [TOTAL] key to call out the total value of accumulation

10. MC key is used to clear out the accumulated counting data.
Operation way : press<MC> key when the M+LED lights, WEIGHT line will show how many times =XX =, UNIT WEIGHT line shows flashed [CLr], press <Enter>light off.

11. SAMPLE key is used when setting the counted number of samples on the platter into the scale memory.

12. UNIT WEIGHT is used when setting the known unit weight data into the scale during normal operation. (1/1000kg or 1/1000lb)

13. QTY/SET key is used when wanting to switch between the pieces counting function and quantity check weighing function.
warning setting of minimum or maximum weight .
Press [QTY/SET] key, the display will show CH=OFF, press [Enter] key to select CH=ON.
press[*] key, UNIT WEIGHT line flashed, press number key to input minimum weight.
press [*] key, TOTAL line flashed, press number key to input maximum weight.
press [QTY/SET] key to exit setting mode and back to weighing mode.
If the weight placed under minimum weight at counting mode, the scale will speak out DU DU DU. If the weight placed exceed maximum weight, the scale will speak out DI DI DI.

14. NUMERIC (0-9) keys are used for setting numeric data for sample numbers, sample weights or to set a limit for the HI/LO settings.

15. [*] Key is used to change the division when the scale is in SCALE 3 mode.

16. TOTAL key displays the accumulated total pieces on the scale

17. ESC key is used to exit from the current menu

18. CE key is used for cancelling the numeric setting data or cancels the previous unit weight data.

4.2 Program options

Besides performing accurate simple weighing, your versatile weighing machine can also perform pieces counting

4.2.1 Pieces counting

4.2.1.1 Counting pieces with known sample unit weight

- Turn scale on
- Wait for "0" to appear on the display.
- If necessary, press ZERO key to set the display to "0"
- Key in unit weight, press UNIT WEIGHT key to confirm
- Store the unit weight by pressing MEM/STORE key, display will show a flashing number for example "01", this is the location where the stored sample unit weight can be found. Press [*] key to toggle between 01-16, press the ENTER key to confirm the selection.
- Press the SCALE/SELECT key to select either SCALE 1 or SCALE 3, be sure to place the additional pieces on the scale that is selected.

***NOTE: The items being weighed should be within the selected scales capacity.

4.2.1.2 Counting pieces without known sample unit weight

- Turn scale on
- Wait for "0" to appear on the display.
- If necessary, press ZERO key to set the display to "0"
- Press SCALE/SELECT key to select SCALE 2, press ENTER to confirm
- Put a pre-known number of samples onto SCALE 2, key-in the known number using the numeric keypad.
- Press SAMPLE to get the sample unit weight
- Press the SCALE/SELECT key to select either SCALE 1 or SCALE 3, be sure to place the additional pieces on the scale that is selected, it will display the total number of items.

***NOTE: The items being weighed should be within the selected scales capacity.

4.2.2 Select a pre-stored unit weight

Key in the number of the pre-stored weight (01-16) using the numeric key pad, press MEM/READ key and select the pre-stored sample unit weight, press ENTER to confirm.

4.2.3 High/Low Check Weighing with Counting

- Turn scale on
- Wait for "0" to appear on the display.
- If necessary, press ZERO key to set the display to "0"
- Press QTY/SET key, display will show CH=OFF or CH=ON
- Press the ENTER key to select "ON"

- Press [*] key, display will show a flashing "0" at UNIT WEIGHT, key in the lower limit using the numeric key pad, press [*] gain, display will show a flashing "0" at TOTAL, key in the upper limit using the numeric keypad.

- Press QTY/SET key to confirm the setting and return to weighing mode.

- Press the SCALE/SELECT key to select either SCALE 1 or SCALE 3, be sure to place the additional pieces on the scale that is selected.

***NOTE: When adding items onto the scale, the scale will beep in a particular tone if the weight (number of items) is less than the lower limit and beep in another tone if it is higher than the upper limit.

5 Calibration - Using an External Calibration Weight:

Calibration is required when the weighing machine is initially installed or if the scale is moved to a substantial distance from the original location. 10 minutes warm up of scale is always needed before calibration.

5.1 Scale 1 Calibration

- Turn on scale
- As the scale is counting down, press the following buttons in order [1], [3], [1], [1] then press ENTER
- Display will show the following: 'WEIGHT DISPLAY' shows SCALE 1, 'UNIT WEIGHT' shows CAL-0, 'TOTAL DISPLAY' will show A/D value
- Press UNIT key to select whether you will calibrate in kg or lb
- Press ENTER to set zero point (UNIT WEIGHT will show CAL-0 flashing for a few seconds and then changes to XXXX to set the calibration weight)
- Press [CE] key and then press the corresponding number buttons based off of the amount of weight you are using to calibrate (example: if you are using 5lbs to calibrate the scale you would key in 5lbs).
- Calibration weight will show in the UNIT WEIGHT display.
- Press the ENTER key, the UNIT WEIGHT display will show flashing XX and then changes to XX.XXX lb. Once this occurs the calibration process is complete.
- ***Note: Make sure nothing is loaded on the platform before you are asked to place the calibration weight. Once calibration is complete you will need to reboot the scale and place the sample test weight on the platter to assure the calibration was completed correctly.

5.2 Scale 2 Calibration

- Turn on scale
- As the scale is counting down, press the following buttons in order [1], [3], [1], [2] then press ENTER
- Display will show the following: 'WEIGHT DISPLAY' shows SCALE 2, 'UNIT WEIGHT' shows CAL-0, 'TOTAL DISPLAY' will show A/D value
- Press UNIT key to select whether you will calibrate in kg or lb

- Press ENTER to set zero point (UNIT WEIGHT will show CAL-0 flashing for a few seconds and then changes to XXXX to set the calibration weight)
- Press [CE] key and then press the corresponding number buttons based off of the amount of weight you are using to calibrate (example: if you are using 1lb to calibrate the scale you would key in 1lb).
- Calibration weight will show in the UNIT WEIGHT display.
- Press the ENTER key, the UNIT WEIGHT display will show flashing XX and then changes to XX.XXX lb. Once this occurs the calibration process is complete.
- ***Note: Make sure nothing is loaded on the platform before you are asked to place the calibration weight. Once calibration is complete you will need to reboot the scale and place the sample test weight on the platter to assure the calibration was completed correctly.

5.3 Scale 3 Calibration

- First make a connection to SCALE 3 through DB9

SCALE 3 DB9	Load Cell DB9
1 S-	1 S-
2 S+	2 S+
3/6 V+	3/6 V+
4 V-	4 V-
5 GND	5 GND
7-9 NC	7-9 NC

- Turn on scale
- As the scale is counting down, press the following buttons in order [1], [3], [1], [3] then press ENTER
- The following must be completed before beginning the calibration process for SCALE 3:
- WEIGHT DISPLAY shows SCALE 3
- UNIT WEIGHT shows “xxx” (this is the full capacity of SCALE 3)
- TOTAL DISPLAY will show “d=xx” (this is the division of SCALE 3)
- Press UNIT key to select full capacity in kg or lb

- Press CE Key to set the full capacity – key in the number through the numeric keypad
- Press (*) to set the division – key in the number through the numeric keypad
- Press ENTER to confirm
- Now begin the CALIBRATION process:
- Press UNIT key to select whether you will calibrate in kg or lb
- Press ENTER to set zero point (UNIT WEIGHT will show CAL-0 flashing for a few seconds and then changes to XXXX to set the calibration weight)
- Press [CE] key and then press the corresponding number buttons based off of the amount of weight you are using to calibrate (example: if you are using 1lb to calibrate the scale you would key in 1lb).
- Calibration weight will show in the UNIT WEIGHT display.
- Press the ENTER key, the UNIT WEIGHT display will show flashing XX and then changes to XX.XXX lb. Once this occurs the calibration process is complete.
- ***Note: Make sure nothing is loaded on the platform before you are asked to place the calibration weight. Once calibration is complete you will need to reboot the scale and place the sample test weight on the platter to assure the calibration was completed correctly.

6 Maintenance and service

The weighing machine must be treated carefully and cleaned regularly. It is a precision instrument.



For maintenance-work, the balance must be separated from the power supply (remove power adapter plug from socket). Also ensure that the balance cannot be reconnected to the power supply during the work by a third party.

Take care during cleaning that no liquid penetrates into the appliance. If liquid is spilt on the balance, the latter must immediately be disconnected from the electricity supply. The balance may only be used again after it has first been checked by a service engineer.

The connections on the rear of the appliance and the power adapter may not come into contact with liquids.

Regularly dismantle the weighing pan and the weighing pan holder and remove any dirt or dust from under the weighing pan and on the weighing machine housing with a soft brush or a soft, lint-free cloth, moistened with a mild soap solution. The scale and the holder can be cleaned under running water. Take care that both parts are completely dry before they are re-installed on the scale.



CAUTION

Never use solvents, acids, alkalis, paint thinners, scouring powders or other aggressive or corrosive chemicals for cleaning, since these substances attack the surfaces of the scale housing and can cause damage.

7 Transport, storage

7.1 Transportation and shipping of the weighing machine

Your weighing machine is a precision instrument. Treat it carefully. Avoid shaking, severe impacts and vibration during the transportation.

Take care that there are no marked temperature fluctuations during the transportation and that the weighing machine does not become damp (condensation).

7.2 Storage of the weighing machine

If you would like to take the weighing machine out of service for an extended period, disconnect it from the electricity supply, clean it thoroughly (see Section 6.Maintenance and servicing.) and store it in a place which meets the following conditions:

- No violent shaking, no vibrations
- Minimum temperature fluctuations
- No direct solar radiation
- Minimum moisture

The weighing machine should preferably be dispatched and transported in the original packaging to avoid transportation damage.

The weighing machine should preferably be stored in the original packaging, since this provides optimal protection for the weighing machine.

