



99 Washington Street
Melrose, MA 02176
Phone 781-665-1400
Toll Free 1-800-517-8431

Defender[®] 5000

Washdown Low Profile Bench Scales

Visit us at www.TestEquipmentDepot.com



Multifunctional Stainless Steel Washdown Bench Scale for Standard Industrial Applications

The OHAUS next generation Defender 5000 Series multifunctional washdown bench scale is ideal for a multitude of applications, including production, packaging, inventory and shipping. Built durably and equipped with advanced features such as maximum configurability print output, GMP/GLP data output, library/user management, and multiple connectivity options - the Defender 5000 is designed to simplify demanding industrial and commercial applications.

Standard Features:

- **Indicator Guides The User with On-Screen Prompts**
See results clearly on the large backlit display. The alpha-numeric keypad and function keys allow for a simplified user experience. On-screen prompts and soft keys will guide you through the operation.
- **Durably Constructed To Withstand Harsh Industrial Environments**
Durably constructed with a stainless steel platform, frame, indicator front mount, IP67 loadcell and IP68/NEMA4X indicator. Supports up to 5,000d NTEP and Measurement Canada certified resolution for legal-for-trade applications.
- **Multiple Application Modes and High Storage Capacity for Greater Flexibility**
Features common industrial modes and supports a 50,000 item library and 1,000 user profiles which can be downloaded/uploaded for easy set-up with the included Micro SD card. Also equipped with GMP/GLP capability with time/date for result traceability.
- **Multiple Connectivity Options for Convenient Data Transfer and Storage**
Results can be stored in the MicroSD card. Data output by built-in RS232 or optional interfaces including 2nd RS232/485/USB Device, Ethernet, Bluetooth/WiFi, Analog Output and Discrete I/O with relays.

Ingeniously Practical

Defender[®] 5000 Washdown Low Profile Bench Scales

Simplified Use

Results can be read easily on the Defender 5000's large transfective dot matrix display, even in bright sunlight. The SmartText 3.0 interface will guide you through all of the Defender 5000's unique and advanced features. With five soft keys, SmartText 3.0 makes an advanced scale very simple to use, and reduces training time for operators.



Durable Construction

The Defender 5000 can be used for both general and legal-for-trade applications. For standard industrial applications, the Defender 5000 bench scales offer durable performance at a practical price.



Simple Operation

Featuring most common applications including Parts Counting with APW optimization, Checkweighing or Checkcounting, Percent Weighing, and Dynamic Weighing or Display Hold, the Defender 5000 meets the weighing and measurement needs of practically every industrial application or manufacturing process. Many application modes eliminate the need for long and complicated manual calculations. GMP/GLP with time/date allows for traceability of results.



Equipped with the included Micro SD card, the Defender 5000 can support storage of up to 50,000 items and 1,000 user profiles. Weighing results can also be stored in Alibi or regular format, addressing all your data storage needs.

Multiple Connectivity Options

Weighing results can be easily exported through the standard RS232 port. Additional connectivity options include a second RS232, RS485 or USB device; Ethernet; and WiFi/Bluetooth interfaces.



Using the Analog Option (either 4-20mA or 0-10V) or the two In/four Out Discrete I/O, the new Defender 5000 indicator can also be used for systems including PLCs.

Indicator Specifications

TD52XW	
Construction	304 stainless steel with sand blasted surface treatment
Protection	IP68 / NEMA 4X
Weighing Units	lb, oz, lb:oz, kg, g, metric ton, short ton, custom unit
Application Modes	Weighing, Percent Weighing, Piece Counting with Optimized APW, Checkweighing/Checkcounting, Dynamic Weighing/Display Hold
Display	Dot matrix LCD with white LED backlight, 256 x 80 pixels
Keyboard	6 function, 5 quick, 12 alpha numeric membrane switches
Auto-zero Tracking	Off, 0.5 d, 1 d or 3 d
Zeroing Range	2% or 100% of capacity
Interface	Standard RS232, Optional Ethernet, WiFi/Bluetooth, 2 nd RS232/RS485/USB, Analog Output, 2 In/4 Out Discrete I/O
Power	100-240 VAC / 50/60 Hz Universal Power Supply, rechargeable lithium battery (Optional)
Battery Life	20 hours of continuous use
Calibration	Zero, Span or 3 point-Linear

Defender® 5000 Washdown Low Profile Bench Scales

Front Mount Bench Scale Specifications

Model	D52XW2WQS5	D52XW5WQS5	D52XW12WQS5	D52XW12WQR5	D52XW25WQR5	D52XW50WQR5	D52XW25WQL5
Capacity × Readability	5 lb × 0.0002 lb 2.5 kg × 0.1 g	10 lb × 0.0005 lb 5 kg × 0.2 g	25 lb × 0.001 lb 12.5 kg × 0.5 g		50 lb × 0.002 lb 25 kg × 1 g	100 lb × 0.005 lb 50 kg × 2 g	50 lb × 0.002 lb 25 kg × 1 g
Maximum Displayed Resolution	1:25,000						
Capacity × Certified Readability	5 lb × 0.001 lb 2.5 kg × 0.5 g	10 lb × 0.002 lb 5 kg × 1 g	25 lb × 0.005 lb 12.5 kg × 5 g		50 lb × 0.01 lb 25 kg × 5 g	100 lb × 0.02 lb 50 kg × 10 g	50 lb × 0.01 lb 25 kg × 5 g
Min APW (g)	0.005	0.01	0.025		0.05	0.1	0.05
Internal Counting Resolution	1:500,000						
Linearity/Repeatability	± 2d						
Indicator	TD52XW						
Mount	Stainless steel front-mount bracket with handle						
Base Construction	Stainless steel removable weighing platform with stainless steel frame, silicon-sealed IP67 stainless steel loadcell						
Safe Overload Capacity	150% of maximum capacity						
Stabilization Time	Within 1 second						
Operating Temperature Range	14°F to 104°F / -10°C to 40°C						
Scale Dimensions (A × B × C × D × E × F)	10 × 10 × 2.9 × 1.8 × 4.6 × 20.8 in 254 × 254 × 74 × 45 × 118 × 529 mm			12 × 12 × 3.7 × 2.4 × 4.6 × 23.1 in 305 × 305 × 95 × 60 × 118 × 588 mm			18 × 18 × 4.3 × 2.8 × 4.6 × 28.9 in 457 × 457 × 110 × 70 × 118 × 734 mm
Shipping Dimensions (L × W × H)	18.9 × 17.5 × 14.3 in 480 × 445 × 363 mm					39.1 × 26.8 × 9.25 in 994 × 680 × 235 mm	
Approx. Net Weight	19.8 lb / 9 kg			22.1 lb / 10 kg			37.5 lb / 17 kg
Approx. Shipping Weight	24.3 lb / 11 kg			26.5 lb / 12 kg			41.9 lb / 19 kg

Model	D52XW50WQL5	D52XW125WQL5	D52XW50WTX5	D52XW125WTX5	D52XW250WTX5	D52XW50WQV5	D52XW125WQV5
Capacity × Readability	100 lb × 0.005 lb 50 kg × 2 g	250 lb × 0.01 lb 125 kg × 5 g	100 lb × 0.005 lb 50 kg × 2 g	250 lb × 0.01 lb 125 kg × 5 g	500 lb × 0.02 lb 250 kg × 10 g	100 lb × 0.005 lb 50 kg × 2 g	250 lb × 0.01 lb 125 kg × 5 g
Maximum Displayed Resolution	1:25,000						
Capacity × Certified Readability	100 lb × 0.02 lb 50 kg × 10 g	250 lb × 0.05 lb 125 kg × 50 g	100 lb × 0.02 lb 50 kg × 10 g	250 lb × 0.05 lb 125 kg × 50 g	500 lb × 0.1 lb 250 kg × 50 g	100 lb × 0.02 lb 50 kg × 10 g	250 lb × 0.05 lb 125 kg × 50 g
Min APW (g)	0.1	0.25	0.1	0.25	0.5	0.1	0.25
Internal Counting Resolution	1:500,000						
Linearity/Repeatability	± 2d						
Indicator	TD52XW						
Mount	Stainless steel front-mount bracket with handle						
Base Construction	Stainless steel removable weighing platform with stainless steel frame, silicon-sealed IP67 stainless steel loadcell						
Safe Overload Capacity	150% of maximum capacity						
Stabilization Time	Within 1 second						
Operating Temperature Range	14°F to 104°F / -10°C to 40°C						
Scale Dimensions (A × B × C × D × E × F)	18 × 18 × 4.3 × 2.8 × 4.6 × 28.9 in 457 × 457 × 110 × 70 × 118 × 734 mm		24 × 18 × 5.1 × 3.5 × 4.6 × 34.9 in 610 × 457 × 130 × 90 × 118 × 887 mm			24 × 24 × 5.1 × 3.5 × 4.6 × 34.6 in 610 × 610 × 130 × 90 × 118 × 880 mm	
Shipping Dimensions (L × W × H)	39.1 × 26.8 × 9.25 in 994 × 680 × 235 mm					45.9 × 30.7 × 9.25 in 1165 × 780 × 235 mm	
Approx. Net Weight	37.5 lb / 17 kg		61.7 lb / 28 kg			79.4 lb / 36 kg	
Approx. Shipping Weight	41.9 lb / 19 kg		68.4 lb / 31 kg			88.2 lb / 40 kg	

Defender[®] 5000 Washdown Low Profile Bench Scales

Application Modes



Weighing: Determine the weight of items in the selected unit of measure.



Percent Weighing: Measure the weight of a sample displayed as a percentage of a pre-established reference weight.



Parts Counting: Count samples of uniform weight. Advanced auto-optimization software recalculates the average piece of weight as the overall weight increases.



Dynamic Weighing and Display Hold: Weigh an unstable load. Scale takes an average of weights over a period of time. The Display Hold feature manually or automatically holds the last stable weight on the display.



Checkweighing/Counting: Compare the weight/count of a sample against target limits. Connect with Discrete I/O and Light Tower Kit for external check lights.

Other Standard Features and Equipment

User-configurable resolution up to 25,000d for general applications and up to 6,250e for legal-for-trade applications (depending on model and unit of measure), 150% overload capacity protection, checkweighing symbols with selectable operation and audible signal settings, menu lock switch, multiple selectable operating languages, selectable environmental and auto-print settings, stability indicator, overload/underload indicators, selectable adjust contrast settings, auto-dim display, auto-off, auto tare, non-slip adjustable rubber feet, a Wheel Kit option is also available for scales up to 300 kg.

Compliance

- **Metrology:** Measurement Canada (Indicator: NoA AM-6093, Platforms: NoA AM-6107); NTEP (Indicator: CC 18-065, Platforms: CC 18-077) Class III
- **Product Safety:** CAN/CSA C22.2 61010-1; UL61010-1; IEC/EN 61010-1
- **Electromagnetic Compatibility:** FCC Part 15 Class B; Canada ICES-003 Class B; IEC/EN 61326-1 Class B, basic environments
- **Compliance Marks:** CE; CSA

Accessories

Battery Kit, Li-ion, TD52	30424405	M16 Gland with Ferrite, to TD52	30379716
USB Host for Dongle, TD52	30424406	Micro SD Card, 8G	30303533
Light Tower, 3 Colors, 243mm, IP65 (Requires 30097591)	30424021	Analog Output Kit, TD52 ³	30424403
In-use Cover Kit, TD52P	30424022	Second RS232/RS485/USB Kit, TD52 ³	30424404
In-use Cover Kit, TD52XW	30424023	I/O with Relay (2 In/4 Out) ³	30097591
In-use Cover set (10), TD52P	30469948	WiFi/BT Dongle, OHAUS ² (Requires 30424406)	30412537
In-use Cover set (10), TD52XW	30469949	Ethernet Kit, D52 ²	30429666
Printer Holder Kit, D52	30424025	Wheel Kit, Defender Series ¹ (For bases up to 300 kg) ..	30372146
Wall Mount Kit, SST, TD52XW	30424026	Impact Printer SF40A	30064203
Wall Mount Kit, CS, TD52P	30424027	Thermal Printer STP-103	80251992
LC Extension Cable, 9 meters, D52 ¹	30424409		

¹ Cannot be used for legal-for-trade applications ² Only one of them can be used at the same time ³ Only one of them can be used at the same time

Test Equipment Depot

 1-800-517-8431

99 Washington Street
 Melrose, MA 02176
 Phone 781-665-1400
 Toll Free 1-800-517-8431

Visit us at www.TestEquipmentDepot.com

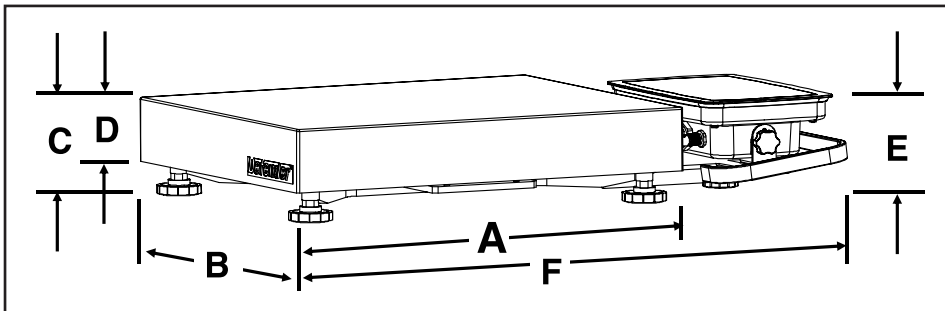

80775516 2018113 © Copyright OHAUS Corporation

The management system governing the manufacture of this product is ISO 9001:2015 certified.

