



# INSTALLATION INSTRUCTIONS



TOYOTA OVERLAND CAT-BACK PART NO. 19546

## BILL OF MATERIALS:

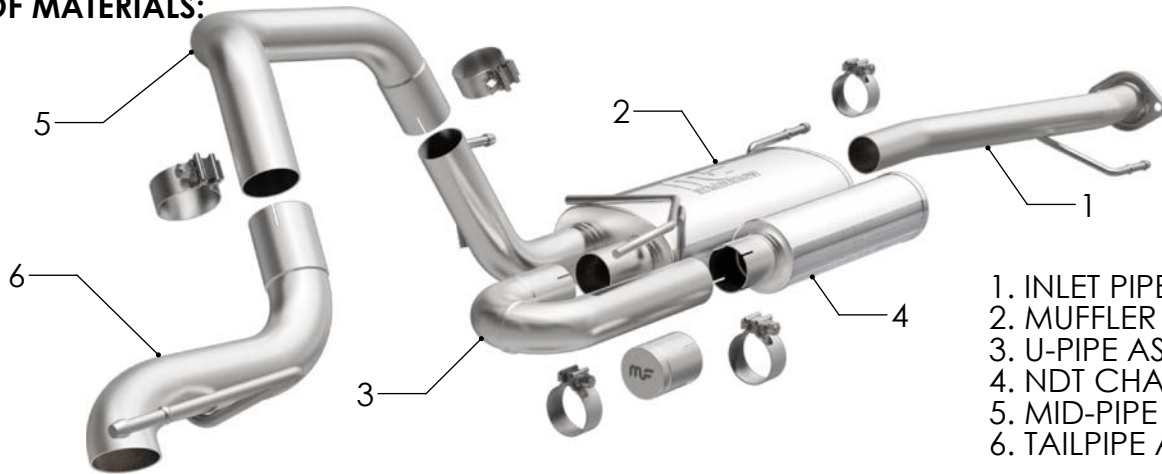

- 1. INLET PIPE ASSY
- 2. MUFFLER ASSY
- 3. U-PIPE ASSY
- 4. NDT CHAMBER
- 5. MID-PIPE
- 6. TAILPIPE ASSY



WEAR SAFETY GLASSES



READ INSTRUCTIONS THOROUGHLY BEFORE INSTALLING PRODUCT



SPRAY LUBRICANT

To ease removal of existing exhaust components (especially on older vehicles) spray penetrating lubricant on all fasteners and hangers/insulators that will be loosened or removed and let soak before disassembly.

## SHOP SUPPLIES:

## HARDWARE KIT:

- 1. [6] 2.50" Torca Clamp
- 2. [1] MF Block Off Pipe.

## MINIMUM REQUIRED TOOLS:



13mm



Hanger Tool (Or Pry Bar)

## MAGNAFLOW RECOMMENDS PROFESSIONAL INSTALLATION ON ALL THEIR PRODUCTS



**WARNING:** When working on, under, or around any vehicle exercise caution. Please allow the vehicle's exhaust system to cool before removal, as exhaust system temperatures may cause severe burns. If working without a lift always consult vehicle manual for correct lifting specifications. Always wear safety glasses and ensure a safe work area. Serious injury or death could occur if safety measures are not followed.

**ATTENTION:** Always install any supplied band or U-bolt clamps to the proper torque specifications of 40-45 ft-lb for band clamps and 30-35 ft-lb for U-bolt clamps. Over tightening will result in the clamps breaking and will NOT be warranted by MagnaFlow.

MAGNAFLOW: 1901 Corporate Centre Dr - Oceanside, CA 92056 | 1(800)990-0905  
Technical Support: 1(800) 959-9226 | Email: moreinfo@magnaflow.com

# INSTALLATION INSTRUCTIONS





**Step 1:** To remove the OE exhaust system begin by unfastening the two bolt spring fasteners towards the front of the vehicle, moving front to rear loosen the clamps and fasteners at the pipe junction points. disengage all welded hangers from the rubber insulators and remove the system. (Retain the rubber insulators and inlet spring bolt fasteners as they will be used to mount the new MagnaFlow system.)



**Step 2:** Begin Installing the new system by attaching the inlet pipe to the Catalytic Converter outlet using the OE spring bolts.



**Step 3:** Next attach the Oval Muffler to the Inlet Pipe with the supplied 2.50" clamp. This exhaust system is configured to allow the user to tune the sound. For a more moderate exhaust tone install the U-pipe Assy and the 4.00" NDT (No Drone Technology) Chamber (as shown) using the supplied 2.50" clamps. For a more aggressive sound see configuration chart below.

	<b>MODERATE TONE:</b> U-PIPE WITH NDT CHAMBER
	<b>AGGRESSIVE TONE:</b> U-PIPE WITH PIPE CAP
	<b>MOST AGGRESSIVE TONE:</b> ONLY PIPE CAP

**MAGNAFLOW:** 1901 Corporate Centre Dr - Oceanside, CA 92056 | 1(800)990-0905  
**Technical Support:** 1(800) 959-9226 | Email: [moreinfo@magnaflow.com](mailto:moreinfo@magnaflow.com)

## INSTALLATION INSTRUCTIONS



Next, loosely attach the Mid-Pipe to the muffler outlet using a supplied 2.50" clamp.



Complete the assembly by loosely attaching the Tailpipe Assembly to the Mid-Pipe using a supplied 2.50" clamp and inserting the hanger into the rubber insulator.

Once a final position has been chosen for the new exhaust system, evenly tighten all clamps from front to rear using the torque specifications on page one of the instructions. Inspect all fasteners after 25-50 miles of operation and re-tighten if necessary.