

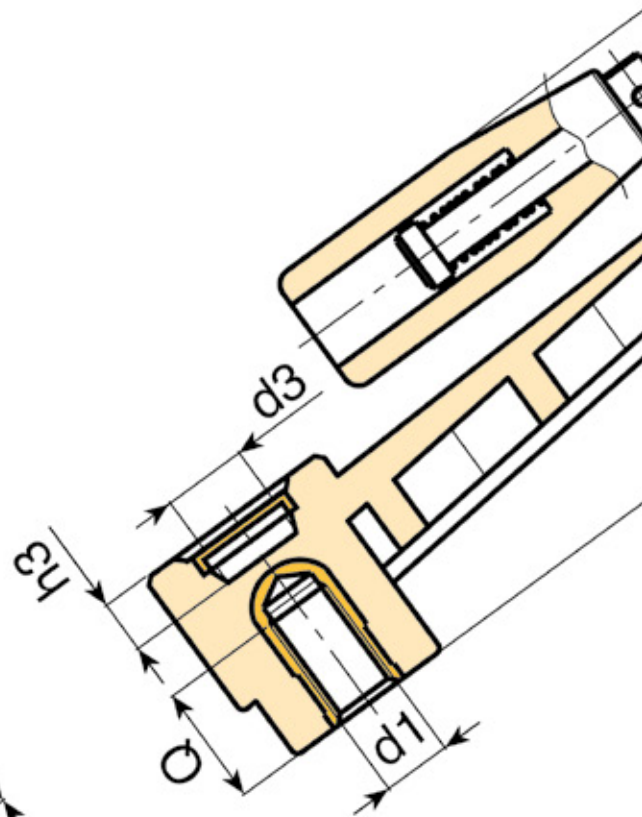

**BOTECO®**

**Family E**

**FIXED AND INDEXED CRANK HANDELS**

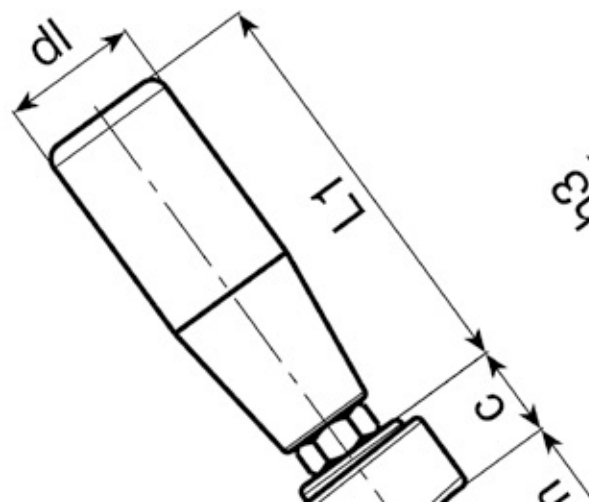

# E215



## CRANK HANDLE WITH THREADED INSERT AND REVOLVING HANDLE

**Material:** Reinforced polyamide. Oils and greases resistant.

**Surface:** Satin.

**Colour:** Black (RAL 9011).

**Central Cap:**  
Grey polyamide RAL 7035 (cod. 13).

**Alternative Cap Colour:**  
Orange (RAL 2004 cod. 02)  
Red (RAL 3000 cod. 16)  
Blue (RAL 5015 cod. 07)  
Green (RAL 6024 cod. 17)  
Yellow (RAL 1021 cod. 10)  
Black (RAL 9011 cod. 01)

**Main Insert:**  
Brass blind threaded bush.  
(\*) Zinc plated steel blind threaded bush.

**Side Insert:** Brass right through threaded bush.

**Side Handle:**  
E215: Revolving handle Art. M144  
E219: Revolving handle Art. M129  
E220: Revolving handle Art. M145

### SPECIAL REQUESTS:

- It is possible to supply the inserts in different materials, on request and for quantities.
- It is possible to supply arm and handle with colours as shown in the table at pag. 23, on request and for quantities.

Art. E215



Art. E219



Art. E220

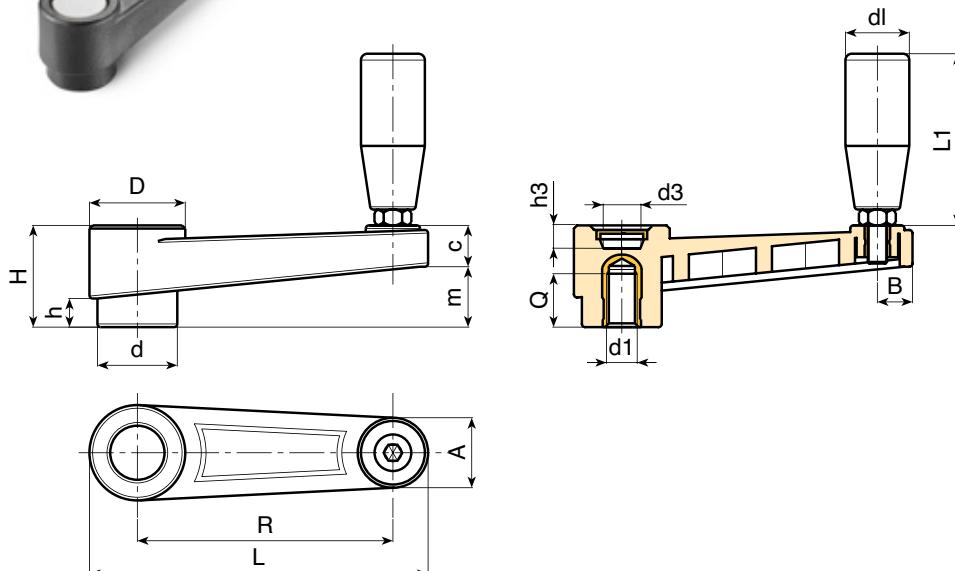

## CRANK HANDLE WITH THREADED INSERT AND REVOLVING HANDLE

## E215

	Art.	L	R	H	D	d	m	c	A	B	h	d3	h3	d1 6H	Q	dl	L1	⚖ g
●	E215065.TM0801	88	65	30	27	22	17	13	18	9,5	8	14	10	M08	15	20	56	67
●	E215065.TM1001	88	65	30	27	22	17	13	18	9,5	8	14	10	M10	15	20	56	70
●	E215065.TM1201	88	65	30	27	22	17	13	18	9,5	8	14	10	M12	18	20	56	73
●	E215080.TM0801	106	80	33	30	26	19	13	21,5	11	9	18	9	M08	18	20	56	83
●	E215080.TM1001	106	80	33	30	26	19	13	21,5	11	9	18	9	M10	18	20	56	87
●	E215080.TM1201	106	80	33	30	26	19	13	21,5	11	9	18	9	M12	18	20	56	90
●	E215110.TM1001	138	110	39	33	29	25	14	22	12	11	18	11	M10	14	21	65	135
●	E215110.TM1201	138	110	39	33	29	25	14	22	12	11	18	11	M12	18	21	65	137
●	E215110.TM1401	138	110	39	33	29	25	14	22	12	11	18	11	M14	18	21	65	140
●	E215140.TM1201	174	140	49	41	35	33	16	25,5	13,5	15	22	19	M12	19	23	76	238
●	E215140.TM1401	174	140	49	41	35	33	16	25,5	13,5	15	22	19	M14	18	23	76	223
●	E215140.TM1601	174	140	49	41	35	33	16	25,5	13,5	15	22	19	(*) M16	18	23	76	251
●	E215185.TM1201	220	185	55	45	40	40	16,5	26,5	14	16,5	28	21	M12	17	25	86	312
●	E215185.TM1401	220	185	55	45	40	40	16,5	26,5	14	16,5	28	21	M14	19	25	86	320
●	E215185.TM1601	220	185	55	45	40	40	16,5	26,5	14	16,5	28	21	(*) M16	18	25	86	331

## CRANK HANDLE WITH THREADED INSERT AND REVOLVING HANDLE M129

## E219

	Art.	L	R	H	D	d	m	c	A	B	h	d3	h3	d1 6H	Q	dl	L1	⚖ g
●	E219065.TM0801	88	65	30	27	22	17	13	18	9,5	8	14	10	M08	15	20	52	79
●	E219065.TM1001	88	65	30	27	22	17	13	18	9,5	8	14	10	M10	15	20	52	82
●	E219065.TM1201	88	65	30	27	22	17	13	18	9,5	8	14	10	M12	18	20	52	85
●	E219080.TM0801	106	80	33	30	26	19	13	21,5	11	9	18	9	M08	18	20	52	95
●	E219080.TM1001	106	80	33	30	26	19	13	21,5	11	9	18	9	M10	18	20	52	99
●	E219080.TM1201	106	80	33	30	26	19	13	21,5	11	9	18	9	M12	18	20	52	102
●	E219110.TM1001	138	110	39	33	29	25	14	22	12	11	18	11	M10	14	23	62	150
●	E219110.TM1201	138	110	39	33	29	25	14	22	12	11	18	11	M12	18	23	62	160
●	E219110.TM1401	138	110	39	33	29	25	14	22	12	11	18	11	M14	18	23	62	165
●	E219140.TM1201	174	140	49	41	35	33	16	25,5	13,5	15	22	19	M12	19	25	72	262
●	E219140.TM1401	174	140	49	41	35	33	16	25,5	13,5	15	22	19	M14	18	25	72	249
●	E219140.TM1601	174	140	49	41	35	33	16	25,5	13,5	15	22	19	(*) M16	18	25	72	275
●	E219185.TM1201	220	185	55	45	40	40	16,5	26,5	14	16,5	28	21	M12	17	25	82	312
●	E219185.TM1401	220	185	55	45	40	40	16,5	26,5	14	16,5	28	21	M14	19	25	82	320
●	E219185.TM1601	220	185	55	45	40	40	16,5	26,5	14	16,5	28	21	(*) M16	18	25	82	331

## CRANK HANDLE WITH THREADED INSERT AND REVOLVING HANDLE M145

## E220

	Art.	L	R	H	D	d	m	c	A	B	h	d3	h3	d1 6H	Q	dl	L1	⚖ g
●	E220065.TM0801	88	65	30	27	22	17	13	18	9,5	8	14	10	M08	15	20	56	69
●	E220065.TM1001	88	65	30	27	22	17	13	18	9,5	8	14	10	M10	15	20	56	72
●	E220065.TM1201	88	65	30	27	22	17	13	18	9,5	8	14	10	M12	18	20	56	75
●	E220080.TM0801	106	80	33	30	26	19	13	21,5	11	9	18	9	M08	18	20	56	85
●	E220080.TM1001	106	80	33	30	26	19	13	21,5	11	9	18	9	M10	18	20	56	89
●	E220080.TM1201	106	80	33	30	26	19	13	21,5	11	9	18	9	M12	18	20	56	92
●	E220110.TM1001	138	110	39	33	29	25	14	22	12	11	18	11	M10	14	23	66	149
●	E220110.TM1201	138	110	39	33	29	25	14	22	12	11	18	11	M12	18	23	66	151
●	E220110.TM1401	138	110	39	33	29	25	14	22	12	11	18	11	M14	18	23	66	154
●	E220140.TM1201	174	140	49	41	35	33	16	25,5	13,5	15	22	19	M12	19	25	77	228
●	E220140.TM1401	174	140	49	41	35	33	16	25,5	13,5	15	22	19	M14	18	25	77	213
●	E220140.TM1601	174	140	49	41	35	33	16	25,5	13,5	15	22	19	(*) M16	18	25	77	241
●	E220185.TM1201	220	185	55	45	40	40	16,5	26,5	14	16,5	28	21	M12	17	25	87	304
●	E220185.TM1401	220	185	55	45	40	40	16,5	26,5	14	16,5	28	21	M14	19	25	87	310
●	E220185.TM1601	220	185	55	45	40	40	16,5	26,5	14	16,5	28	21	(*) M16	18	25	87	321

# E218



## CRANK HANDLE WITH THREADED INSERT AND REVOLVING AND FOLDING HANDLE

**Material:** Reinforced polyamide. Oils and greases resistant.

**Surface:** Satin.

**Colour:** Black (RAL 9011).

**Central Cap:**  
Grey polyamide RAL 7035 (cod. 13).

**Alternative Cap Colour:**  
Orange (RAL 2004 cod. 02)  
Red (RAL 3000 cod. 16)  
Blue (RAL 5015 cod. 07)  
Green (RAL 6024 cod. 17)  
Yellow (RAL 1021 cod. 10)  
Black (RAL 9011 cod. 01)

**Main Insert:**  
Brass blind threaded bush.  
(\*) Zinc plated steel blind threaded bush.

**Side Insert:** Brass right through threaded bush.

**Side Handle:** Revolving and folding handle Art. M136.



### SPECIAL REQUESTS:

- It is possible to supply the inserts in different materials, on request and for quantities.
- It is possible to supply arm and handle with colours as shown in the table at pag. 23, on request and for quantities.

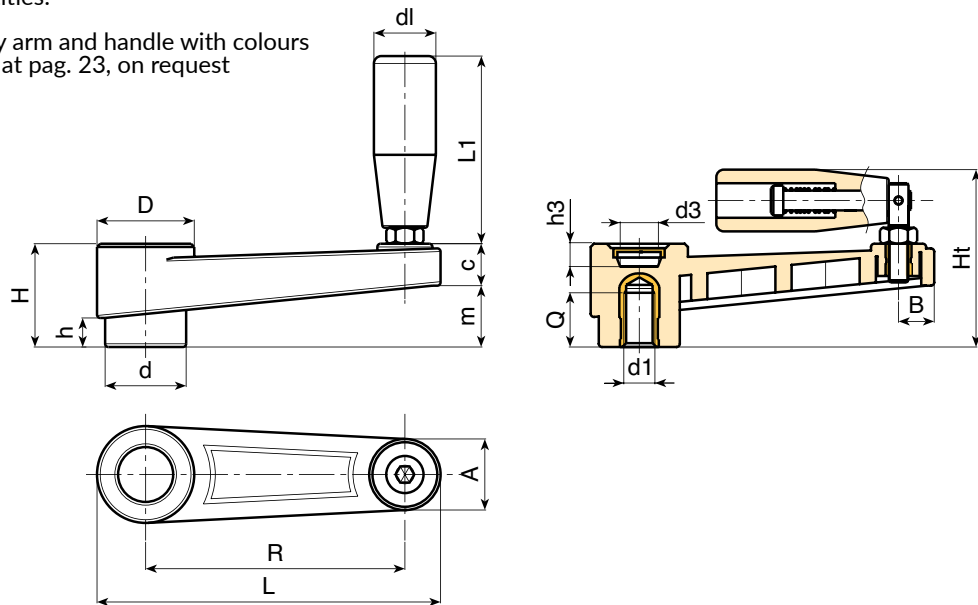

	Art.	L	R	H	Ht	D	d	m	c	A	B	h	d3	h3	d1 6H	Q	dl	L1	△ g
●	E218065.TM0801	88	65	30	54	27	22	17	13	18	9,5	8	14	10	M08	15	20	54	78
●	E218065.TM1001	88	65	30	54	27	22	17	13	18	9,5	8	14	10	M10	15	20	54	78
●	E218065.TM1201	88	65	30	54	27	22	17	13	18	9,5	8	14	10	M12	18	20	54	83
●	E218080.TM0801	106	80	33	57	30	26	19	13	21,5	11	9	18	9	M08	18	20	54	94
●	E218080.TM1001	106	80	33	57	30	26	19	13	21,5	11	9	18	9	M10	18	20	54	95
●	E218080.TM1201	106	80	33	57	30	26	19	13	21,5	11	9	18	9	M12	18	20	54	100
●	E218110.TM1001	138	110	39	67,5	33	29	25	14	22	12	11	18	11	M10	16	25	75	156
●	E218110.TM1201	138	110	39	67,5	33	29	25	14	22	12	11	18	11	M12	18	25	75	156
●	E218110.TM1401	138	110	39	67,5	33	29	25	14	22	12	11	18	11	M14	18	25	75	156
●	E218140.TM1201	174	140	49	82	41	35	33	16	25,5	13,5	15	22	19	M12	19	26	89	274
●	E218140.TM1401	174	140	49	82	41	35	33	16	25,5	13,5	15	22	19	M14	18	26	89	283
●	E218140.TM1601	174	140	49	82	41	35	33	16	25,5	13,5	15	22	19	M16 (*)	18	26	89	290
●	E218185.TM1201	220	185	55	88	45	40	40	16,5	26,5	14	16,5	28	21	M12	17	26	97	340
●	E218185.TM1401	220	185	55	88	45	40	40	16,5	26,5	14	16,5	28	21	M14	19	26	97	345
●	E218185.TM1601	220	185	55	88	45	40	40	16,5	26,5	14	16,5	28	21	M16 (*)	18	26	97	360

# E217



## CRANK HANDLE WITH SMOOTH INSERT AND REVOLVING AND FOLDING HANDLE

**Material:** Reinforced polyamide. Oils and greases resistant.

**Surface:** Satin.

**Colour:** Black (RAL 9011).

**Central Cap:** Grey polyamide RAL 7035 (cod. 13).

**Alternative Cap Colour:**

- Orange (RAL 2004 cod. 02)
- Red (RAL 3000 cod. 16)
- Blue (RAL 5015 cod. 07)
- Green (RAL 6024 cod. 17)
- Yellow (RAL 1021 cod. 10)
- Black (RAL 9011 cod. 01)

**Main Insert:**

Zinc plated steel insert with smooth through-hole (H10 tolerance).

**Side Insert:** Brass right through threaded bush.

**Side Handle:** Revolving and folding handle Art. M136.



**SPECIAL REQUESTS:**

- It is possible to supply the inserts with d1 diameter by customer design, on request and for quantities.
- It is possible to supply the inserts in different materials, on request and for quantities.
- It is possible to supply the inserts in different treatment-finishes, on request and for quantities.
- It is possible to supply arm and handle with colours as shown in the table at pag. 23, on request and for quantities.

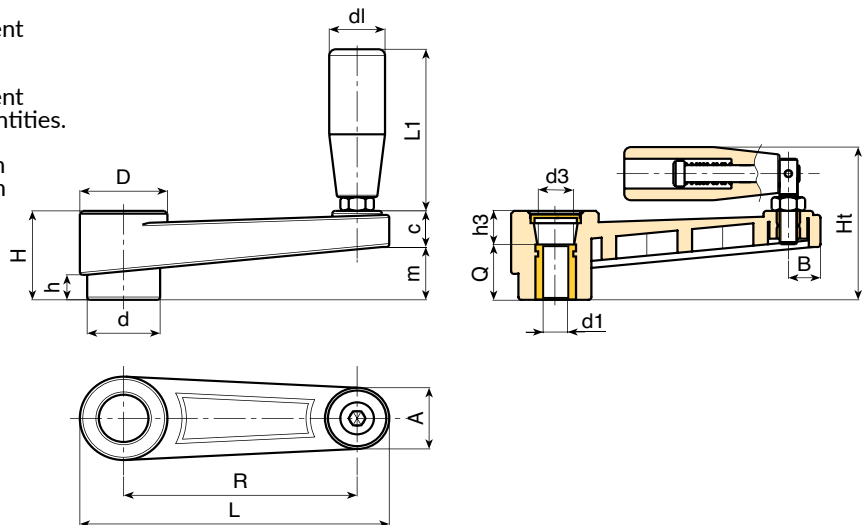

Art.	L	R	H	Ht	D	d	m	c	A	B	h	d3	h3	dm	d1 H10	Q	dl	L1	Δg
E217065.TP0501	88	65	30	54	27	22	17	13	18	9,5	8	14	10	12	05	20	20	54	105
E217065.TD1001	88	65	30	54	27	22	17	13	18	9,5	8	14	10	12	10	20	20	54	100
E217065.TD1201	88	65	30	54	27	22	17	13	18	9,5	8	14	10	12	12	20	20	54	97
E217080.TP0501	106	80	33	57	30	26	19	13	21,5	11	9	18	9	14	05	24	20	54	115
E217080.TD1001	106	80	33	57	30	26	19	13	21,5	11	9	18	9	14	10	24	20	54	110
E217080.TD1201	106	80	33	57	30	26	19	13	21,5	11	9	18	9	14	12	24	20	54	107
E217110.TD0801	138	110	39	67,5	33	29	25	14	22	12	11	18	11	14	08	28	25	75	156
E217110.TD1001	138	110	39	67,5	33	29	25	14	22	12	11	18	11	14	10	28	25	75	153
E217110.TD1201	138	110	39	67,5	33	29	25	14	22	12	11	18	11	14	12	28	25	75	150
E217140.TD0801	174	140	49	82	41	35	33	16	25,5	13,5	15	22	19	20	05	30	26	89	300
E217140.TD1201	174	140	49	82	41	35	33	16	25,5	13,5	15	22	19	20	12	30	26	89	245
E217140.TD1401	174	140	49	82	41	35	33	16	25,5	13,5	15	22	19	20	14	30	26	89	242
E217140.TD1601	174	140	49	82	41	35	33	16	25,5	13,5	15	22	19	20	16	30	26	89	238
E217185.TD0801	220	185	55	88	45	40	40	16,5	26,5	14	16,5	28	21	22	08	34	26	97	450
E217185.TD1201	220	185	55	88	45	40	40	16,5	26,5	14	16,5	28	21	22	12	34	26	97	445

dm = It's possible to increase the hole, by boring, until Dm (enlarge).

Presumable presence in the stock in %   
 90% ● 40% ● 5% ●

# E216

## CRANK HANDLE WITH SMOOTH INSERT AND REVOLVING HANDLE

Art. E216

**Material:** Reinforced polyamide. Oils and greases resistant.

**Surface:** Satin.

**Colour:** Black (RAL 9011).

**Central Cap:**  
Grey polyamide RAL 7035 (cod. 13).

**Alternative Cap Colour:**  
Orange (RAL 2004 cod. 02)  
Red (RAL 3000 cod. 16)  
Blue (RAL 5015 cod. 07)  
Green (RAL 6024 cod. 17)  
Yellow (RAL 1021 cod. 10)  
Black (RAL 9011 cod. 01)

**Main Insert:**  
Zinc plated steel insert with smooth through-hole (H10 tolerance).

**Side Insert:** Brass right through threaded bush.

**Side Handle:**  
E216: Revolving handle Art. M144  
E221: Revolving handle Art. M145  
E222: Revolving handle Art. M129.

### SPECIAL REQUESTS:

- It is possible to supply the inserts with d1 diameter by customer design, on request and for quantities.
- It is possible to supply the inserts in different materials, on request and for quantities.
- It is possible to supply the inserts in different treatment-finishes, on request and for quantities.
- It is possible to supply arm and handle with colours as shown in the table at pag. 23, on request and for quantities.



Art. E221

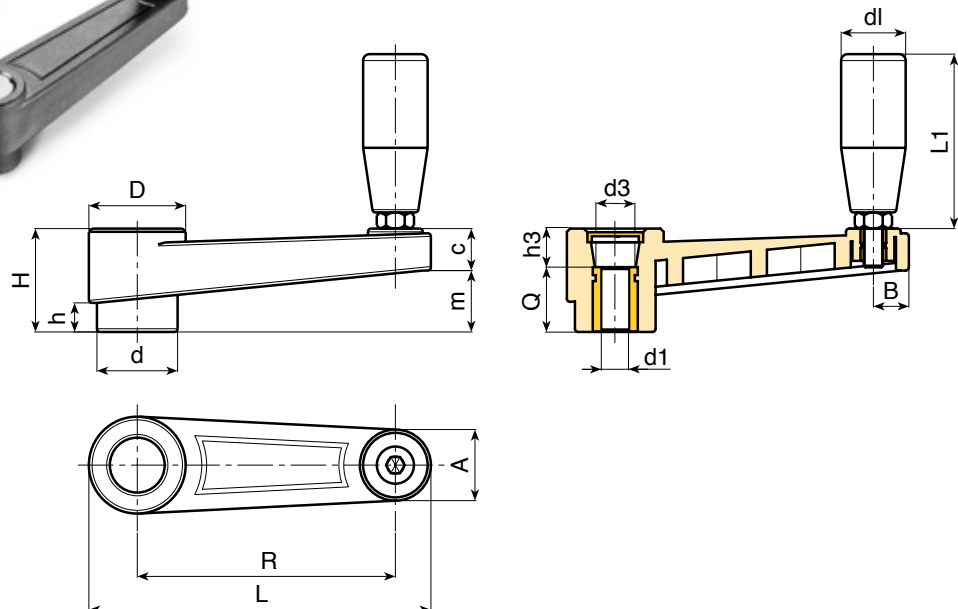



## CRANK HANDLE WITH SMOOTH INSERT AND REVOLVING HANDLE

# E216

	Art.	L	R	H	D	d	m	c	A	B	h	d3	h3	dm	d1 H10	Q	dl	L1	Δ g
●	E216065.TP0501	88	65	30	27	22	17	13	18	9,5	8	14	10	12	05	20	20	56	96
●	E216065.TD1001	88	65	30	27	22	17	13	18	9,5	8	14	10	12	10	20	20	56	92
●	E216065.TD1201	88	65	30	27	22	17	13	18	9,5	8	14	10	12	12	20	20	56	89
●	E216080.TP0501	106	80	33	30	26	19	13	21,5	11	9	18	9	14	05	24	20	56	110
●	E216080.TD1001	106	80	33	30	26	19	13	21,5	11	9	18	9	14	10	24	20	56	105
●	E216080.TD1201	106	80	33	30	26	19	13	21,5	11	9	18	9	14	12	24	20	56	102
●	E216110.TD0801	138	110	39	33	29	22	14	22	12	11	18	11	14	05	28	21	66	160
●	E216110.TD1001	138	110	39	33	29	22	14	22	12	11	18	11	14	10	28	21	66	152
●	E216110.TD1201	138	110	39	33	29	22	14	22	12	11	18	11	14	12	28	21	66	148
●	E216140.TD0801	174	140	49	41	35	34	16	25,5	13,5	15	22	19	20	08	30	23	76	250
●	E216140.TD1201	174	140	49	41	35	34	16	25,5	13,5	15	22	19	20	12	30	23	76	242
●	E216140.TD1401	174	140	49	41	35	34	16	25,5	13,5	15	22	19	20	14	30	23	76	238
●	E216140.TD1601	174	140	49	41	35	34	16	25,5	13,5	15	22	19	20	16	30	23	76	232
●	E216185.TD0801	220	185	55	45	40	40	16,5	26,5	14	16,5	28	21	22	08	34	25	86	430
●	E216185.TD1201	220	185	55	45	40	40	16,5	26,5	14	16,5	28	21	22	12	34	25	86	400

dm = It's possible to increase the hole, by boring, until Dm (enlarge).

## CRANK HANDLE WITH SMOOTH INSERT AND REVOLVING HANDLE M145

# E221

	Art.	L	R	H	D	d	m	c	A	B	h	d3	h3	dm	d1 H10	Q	dl	L1	Δ g
●	E221065.TP0501	88	65	30	27	22	17	13	18	9,5	8	14	10	12	05	20	20	56	101
●	E221065.TD1001	88	65	30	27	22	17	13	18	9,5	8	14	10	12	10	20	20	56	107
●	E221065.TD1201	88	65	30	27	22	17	13	18	9,5	8	14	10	12	12	20	20	56	104
●	E221080.TP0501	106	80	33	30	26	19	13	21,5	11	9	18	9	14	05	24	20	56	125
●	E221080.TD1001	106	80	33	30	26	19	13	21,5	11	9	18	9	14	10	24	20	56	130
●	E221080.TD1201	106	80	33	30	26	19	13	21,5	11	9	18	9	14	12	24	20	56	127
●	E221110.TD0801	138	110	39	33	29	22	14	22	12	11	18	11	14	05	28	23	66	175
●	E221110.TD1001	138	110	39	33	29	22	14	22	12	11	18	11	14	10	28	23	66	172
●	E221110.TD1201	138	110	39	33	29	22	14	22	12	11	18	11	14	12	28	23	66	169
●	E221140.TD0801	174	140	49	41	35	34	16	25,5	13,5	15	22	19	20	08	30	25	77	263
●	E221140.TD1201	174	140	49	41	35	34	16	25,5	13,5	15	22	19	20	12	30	25	77	257
●	E221140.TD1401	174	140	49	41	35	34	16	25,5	13,5	15	22	19	20	14	30	25	77	253
●	E221140.TD1601	174	140	49	41	35	34	16	25,5	13,5	15	22	19	20	16	30	25	77	249
●	E221185.TD0801	220	185	55	45	40	40	16,5	26,5	14	16,5	28	21	22	08	34	25	87	440
●	E221185.TD1201	220	185	55	45	40	40	16,5	26,5	14	16,5	28	21	22	12	34	25	87	433

dm = It's possible to increase the hole, by boring, until Dm (enlarge).

## CRANK HANDLE WITH SMOOTH INSERT AND REVOLVING HANDLE M129

# E222

	Art.	L	R	H	D	d	m	c	A	B	h	d3	h3	dm	d1 H10	Q	dl	L1	Δ g
●	E222065.TP0501	88	65	30	27	22	17	13	18	9,5	8	14	10	12	05	20	20	52	111
●	E222065.TD1001	88	65	30	27	22	17	13	18	9,5	8	14	10	12	10	20	20	52	117
●	E222065.TD1201	88	65	30	27	22	17	13	18	9,5	8	14	10	12	12	20	20	52	114
●	E222080.TP0501	106	80	33	30	26	19	13	21,5	11	9	18	9	14	05	24	20	52	135
●	E222080.TD1001	106	80	33	30	26	19	13	21,5	11	9	18	9	14	10	24	20	52	140
●	E222080.TD1201	106	80	33	30	26	19	13	21,5	11	9	18	9	14	12	24	20	52	136
●	E222110.TD0801	138	110	39	33	29	22	14	22	12	11	18	11	14	08	28	23	62	182
●	E222110.TD1001	138	110	39	33	29	22	14	22	12	11	18	11	14	10	28	23	62	179
●	E222110.TD1201	138	110	39	33	29	22	14	22	12	11	18	11	14	12	28	23	62	175
●	E222140.TD0801	174	140	49	41	35	34	16	25,5	13,5	15	22	19	20	08	30	25	72	271
●	E222140.TD1201	174	140	49	41	35	34	16	25,5	13,5	15	22	19	20	12	30	25	72	265
●	E222140.TD1401	174	140	49	41	35	34	16	25,5	13,5	15	22	19	20	14	30	25	72	261
●	E222140.TD1601	174	140	49	41	35	34	16	25,5	13,5	15	22	19	20	16	30	25	72	255
●	E222185.TD0801	220	185	55	45	40	40	16,5	26,5	14	16,5	28	21	22	08	34	25	82	450
●	E222185.TD1201	220	185	55	45	40	40	16,5	26,5	14	16,5	28	21	22	12	34	25	82	442

dm = It's possible to increase the hole, by boring, until Dm (enlarge).

Presumable presence in the stock in %

90% ●

40% ●

5% ●



E

# E224

## CRANK HANDLE WITH HEXAGONAL STUD AND REVOLVING HANDLE

**Material:** Reinforced polyamide. Oils and greases resistant.

**Surface:** Satin.

**Colour:** Black (RAL 9011).

**Central Cap:**  
Grey polyamide RAL 7035 (cod. 13).

Art. E224

**Alternative Cap Colour:**  
Orange (RAL 2004 cod. 02)  
Red (RAL 3000 cod. 16)  
Blue (RAL 5015 cod. 07)  
Green (RAL 6024 cod. 17)  
Yellow (RAL 1021 cod. 10)  
Black (RAL 9011 cod. 01)

**Main Insert:**  
Zinc plated steel hexagonal stud.

**Side Insert:** Brass right through threaded bush.

**Side Handle:**  
E224: Revolving handle Art. M144  
E226: Revolving handle Art. M145  
E227: Revolving handle Art. M129.



### SPECIAL REQUESTS:

- It is possible to supply inserts in different lengths or by special design, on request and for quantities.
- It is possible to supply the inserts in different treatment-finishes, on request and for quantities.
- It is possible to supply arm and handle with colours as shown in the table at pag. 23, on request and for quantities.

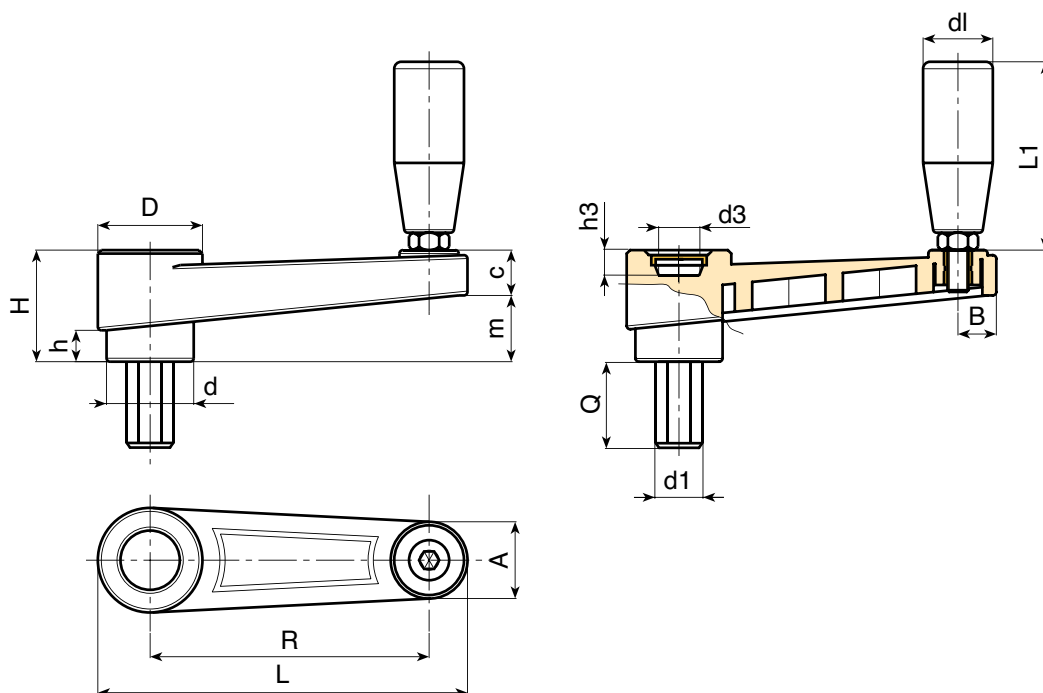





## CRANK HANDLE WITH HEXAGONAL STUD AND REVOLVING HANDLE

# E224

	Art.	L	R	H	D	d	m	c	A	B	h	d3	h3	d1 H10	Q	LM	dl	L1	
●	E224065.TE06X..01	88	65	30	27	22	17	13	18	9,5	8	14	10	6	A.R.	60	20	56	-
●	E224065.TE07X..01	88	65	30	27	22	17	13	18	9,5	8	14	10	7	A.R.	60	20	56	-
●	E224080.TE07X..01	106	80	33	30	26	19	13	21,5	11	9	18	9	7	A.R.	100	20	56	-
●	E224080.TE08X..01	106	80	33	30	26	19	13	21,5	11	9	18	9	8	A.R.	100	20	56	-
●	E224110.TE08X..01	138	110	39	33	29	22	14	22	12	11	18	11	8	A.R.	90	21	66	-
●	E224110.TE09X..01	138	110	39	33	29	22	14	22	12	11	18	11	9	A.R.	90	21	66	-
●	E224140.TE09X..01	174	140	49	41	35	34	16	25,5	13,5	15	22	19	9	A.R.	110	23	76	-
●	E224140.TE10X..01	174	140	49	41	35	34	16	25,5	13,5	15	22	19	10	A.R.	110	23	76	-

LM = Maximum mouldable length

A.R.= Upon request

## CRANK HANDLE WITH HEXAGONAL STUD AND REVOLVING HANDLE M145

# E226

	Art.	L	R	H	D	d	m	c	A	B	h	d3	h3	d1 H10	Q	LM	dl	L1	
●	E226065.TE06X..01	88	65	30	27	22	17	13	18	9,5	8	14	10	6	A.R.	60	20	56	-
●	E226065.TE07X..01	88	65	30	27	22	17	13	18	9,5	8	14	10	7	A.R.	60	20	56	-
●	E226080.TE07X..01	106	80	33	30	26	19	13	21,5	11	9	18	9	7	A.R.	100	20	56	-
●	E226080.TE08X..01	106	80	33	30	26	19	13	21,5	11	9	18	9	8	A.R.	100	20	56	-
●	E226110.TE08X..01	138	110	39	33	29	22	14	22	12	11	18	11	8	A.R.	90	21	66	-
●	E226110.TE09X..01	138	110	39	33	29	22	14	22	12	11	18	11	9	A.R.	90	21	66	-
●	E226140.TE09X..01	174	140	49	41	35	34	16	25,5	13,5	15	22	19	9	A.R.	110	23	76	-
●	E226140.TE10X..01	174	140	49	41	35	34	16	25,5	13,5	15	22	19	10	A.R.	110	23	76	-

LM = Maximum mouldable length

A.R.= Upon request

## CRANK HANDLE WITH HEXAGONAL STUD AND REVOLVING HANDLE M129

# E227

	Art.	L	R	H	D	d	m	c	A	B	h	d3	h3	d1 H10	Q	LM	dl	L1	
●	E227065.TE06X..01	88	65	30	27	22	17	13	18	9,5	8	14	10	6	A.R.	60	20	56	-
●	E227065.TE07X..01	88	65	30	27	22	17	13	18	9,5	8	14	10	7	A.R.	60	20	56	-
●	E227080.TE07X..01	106	80	33	30	26	19	13	21,5	11	9	18	9	7	A.R.	100	20	56	-
●	E227080.TE08X..01	106	80	33	30	26	19	13	21,5	11	9	18	9	8	A.R.	100	20	56	-
●	E227110.TE08X..01	138	110	39	33	29	22	14	22	12	11	18	11	8	A.R.	90	21	66	-
●	E227110.TE09X..01	138	110	39	33	29	22	14	22	12	11	18	11	9	A.R.	90	21	66	-
●	E227140.TE09X..01	174	140	49	41	35	34	16	25,5	13,5	15	22	19	9	A.R.	110	23	76	-
●	E227140.TE10X..01	174	140	49	41	35	34	16	25,5	13,5	15	22	19	10	A.R.	110	23	76	-

LM = Maximum mouldable length

A.R.= Upon request

# E230

## CRANK HANDLE WITH HEXAGONAL HOLE AND REVOLVING HANDLE

**Material:** Reinforced polyamide. Oils and greases resistant.

Art. E230

**Surface:** Satin.

**Colour:** Black (RAL 9011).

**Central Cap:**  
Grey polyamide RAL 7035 (cod. 13).

**Alternative Cap Colour:**  
Orange (RAL 2004 cod. 02)  
Red (RAL 3000 cod. 16)  
Blue (RAL 5015 cod. 07)  
Green (RAL 6024 cod. 17)  
Yellow (RAL 1021 cod. 10)  
Black (RAL 9011 cod. 01)

**Main Insert:**  
Black-oxide treated insert, with hexagonal through-hole (H10 tolerance).

**Side Laterale:** Brass right through threaded bush.

**Side Handle:**  
E230: Revolving handle Art. M144  
E231: Revolving handle Art. M145  
E232: Revolving handle Art. M129.

Art. E231

### SPECIAL REQUESTS:

- It is possible to supply the inserts in different treatment-finishes, on request and for quantities.
- It is possible to supply arm and handle with colours as shown in the table at pag. 23, on request and for quantities.

Art. E232

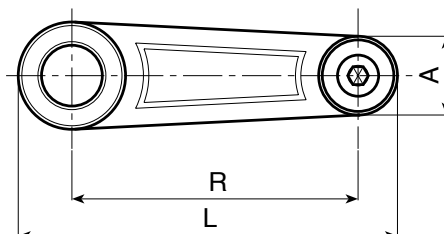
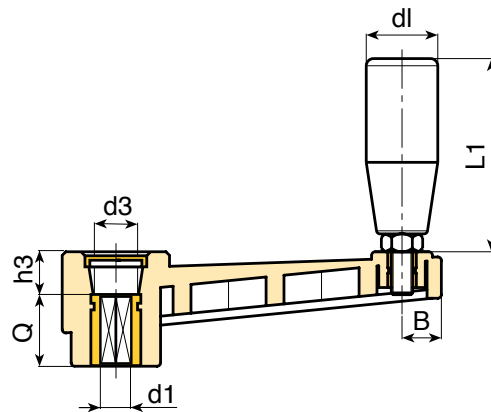
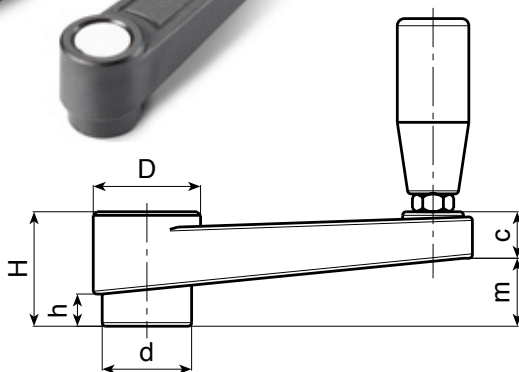



## CRANK HANDLE WITH HEXAGONAL HOLE AND REVOLVING HANDLE

# E230

	Art.	L	R	H	D	d	m	c	A	B	h	d3	h3	d1 H10	Q	dl	L1	g
●	E230065.TE0601P	88	65	30	27	22	17	13	18	9,5	8	14	10	6	20	20	56	96
●	E230065.TE0801P	88	65	30	27	22	17	13	18	9,5	8	14	10	8	20	20	56	93
●	E230080.TE1001P	106	80	33	30	26	19	13	21,5	11	9	18	9	10	24	20	56	105
●	E230080.TE1201P	106	80	33	30	26	19	13	21,5	11	9	18	9	12	24	20	56	103
●	E230110.TE1201P	138	110	39	33	29	22	14	22	12	11	18	11	12	28	21	66	152
●	E230110.TE1401P	138	110	39	33	29	22	14	22	12	11	18	11	14	28	21	66	149
●	E230140.TE1401P	174	140	49	41	35	34	16	25,5	13,5	15	22	19	14	30	23	76	242
●	E230140.TE1601P	174	140	49	41	35	34	16	25,5	13,5	15	22	19	16	30	23	76	238
●	E230185.TE1601P	220	185	55	45	40	40	16,5	26,5	14	16,5	22	19	16	34	25	86	385
●	E230185.TE1701P	220	185	55	45	40	40	16,5	26,5	14	16,5	22	19	17	34	25	86	385

## CRANK HANDLE WITH HEXAGONAL HOLE - REVOLVING HANDLE M145 -

# E231

	Art.	L	R	H	D	d	m	c	A	B	h	d3	h3	d1 H10	Q	dl	L1	g
●	E231065.TE0601P	88	65	30	27	22	17	13	18	9,5	8	14	10	6	20	20	56	111
●	E231065.TE0801P	88	65	30	27	22	17	13	18	9,5	8	14	10	8	20	20	56	108
●	E231080.TE1001P	106	80	33	30	26	19	13	21,5	11	9	18	9	10	24	20	56	130
●	E231080.TE1201P	106	80	33	30	26	19	13	21,5	11	9	18	9	12	24	20	56	128
●	E231110.TE1201P	138	110	39	33	29	22	14	22	12	11	18	11	12	28	21	66	177
●	E231110.TE1401P	138	110	39	33	29	22	14	22	12	11	18	11	14	28	21	66	173
●	E231140.TE1401P	174	140	49	41	35	34	16	25,5	13,5	15	22	19	14	30	23	76	267
●	E231140.TE1601P	174	140	49	41	35	34	16	25,5	13,5	15	22	19	16	30	23	76	262
●	E231185.TE1601P	220	185	55	45	40	40	16,5	26,5	14	16,5	22	19	16	34	25	86	400
●	E231185.TE1701P	220	185	55	45	40	40	16,5	26,5	14	16,5	22	19	17	34	25	86	398

## CRANK HANDLE WITH HEXAGONAL HOLE - REVOLVING HANDLE M129 -

# E232

	Art.	L	R	H	D	d	m	c	A	B	h	d3	h3	d1 H10	Q	dl	L1	g
●	E232065.TE0601P	88	65	30	27	22	17	13	18	9,5	8	14	10	6	20	20	56	101
●	E232065.TE0801P	88	65	30	27	22	17	13	18	9,5	8	14	10	8	20	20	56	98
●	E232080.TE1001P	106	80	33	30	26	19	13	21,5	11	9	18	9	10	24	20	56	120
●	E232080.TE1201P	106	80	33	30	26	19	13	21,5	11	9	18	9	12	24	20	56	118
●	E232110.TE1201P	138	110	39	33	29	22	14	22	12	11	18	11	12	28	21	66	167
●	E232110.TE1401P	138	110	39	33	29	22	14	22	12	11	18	11	14	28	21	66	163
●	E232140.TE1401P	174	140	49	41	35	34	16	25,5	13,5	15	22	19	14	30	23	76	257
●	E232140.TE1601P	174	140	49	41	35	34	16	25,5	13,5	15	22	19	16	30	23	76	252
●	E232185.TE1601P	220	185	55	45	40	40	16,5	26,5	14	16,5	22	19	16	34	25	86	390
●	E232 185.TE1701P	220	185	55	45	40	40	16,5	26,5	14	16,5	22	19	17	34	25	86	390

# E330

## CRANK HANDLE WITH SQUARE HOLE AND REVOLVING HANDLE

Art. E330

**Material:** Reinforced polyamide. Oils and greases resistant.

**Surface:** Satin.

**Colour:** Black (RAL 9011).

**Central Cap:** Grey polyamide RAL 7035 (cod. 13).

**Alternative Cap Colour:**  
 Orange (RAL 2004 cod. 02)  
 Red (RAL 3000 cod. 16)  
 Blue (RAL 5015 cod. 07)  
 Green (RAL 6024 cod. 17)  
 Yellow (RAL 1021 cod. 10)  
 Black (RAL 9011 cod. 01)

**Main Insert:** Black-oxide treated insert, with square through-hole, H10 tolerance.

**Side Insert:** Brass right through threaded bush.

**Side Handle:**  
 E330: Revolving handle Art. M144  
 E331: Revolving handle Art. M145  
 E332: Revolving handle Art. M129.

### SPECIAL REQUESTS:

- It is possible to supply the inserts in different treatment-finishes, on request and for quantities.
- It is possible to supply arm and handle with colours as shown in the table at pag. 23, on request and for quantities.



Art. E331



Art. E332

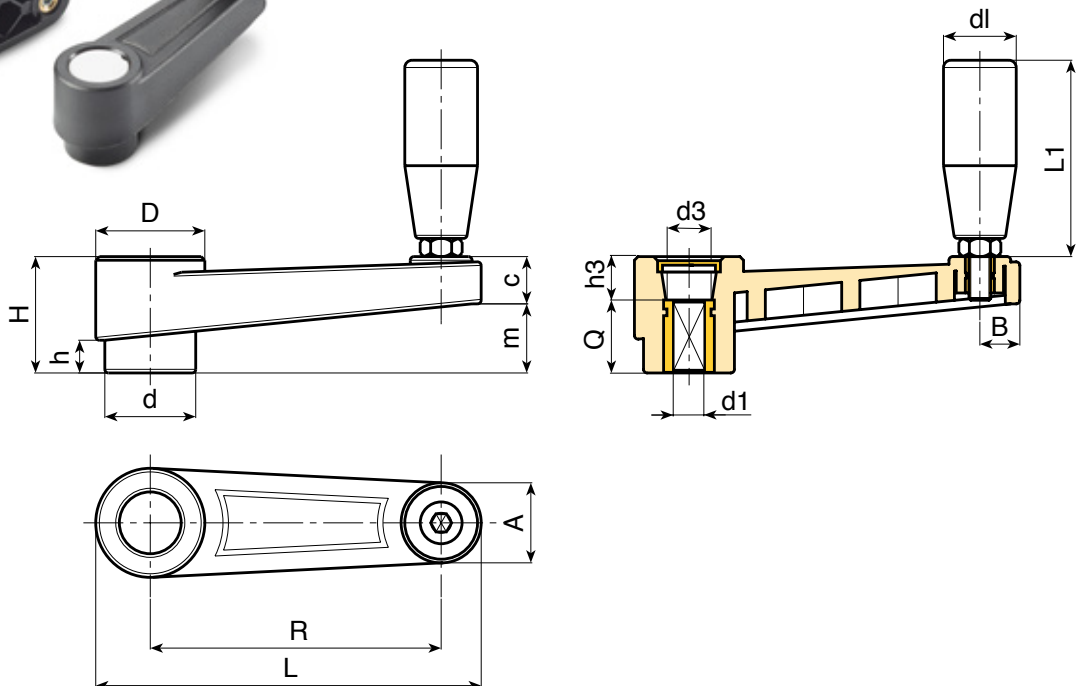



## CRANK HANDLE WITH SQUARE HOLE AND REVOLVING HANDLE

# E330

	Art.	L	R	H	D	d	m	c	A	B	h	d3	h3	d1 H10	Q	dl	L1	Δg
●	E330065.TQ0601P	88	65	30	27	22	17	13	18	9,5	8	14	10	□ 6	20	20	56	96
●	E330065.TQ0801P	88	65	30	27	22	17	13	18	9,5	8	14	10	□ 8	20	20	56	92
●	E330080.TQ1001P	106	80	33	30	26	19	13	21,5	11	9	18	9	□ 10	24	20	56	105
●	E330110.TQ1201P	138	110	39	33	29	22	14	22	12	11	18	11	□ 12	28	21	66	152
●	E330140.TQ1401P	174	140	49	41	35	34	16	25,5	13,5	15	22	19	□ 14	30	23	76	242
●	E330185.TQ1701P	220	185	55	45	40	40	16,5	26,5	14	16,5	28	21	□ 17	34	25	86	385

E

## CRANK HANDLE WITH SQUARE HOLE -REVOLVING HANDLE M145

# E331

	Art.	L	R	H	D	d	m	c	A	B	h	d3	h3	d1 H10	Q	dl	L1	Δg
●	E331065.TQ0601P	88	65	30	27	22	17	13	18	9,5	8	14	10	□ 6	20	20	56	111
●	E331065.TQ0801P	88	65	30	27	22	17	13	18	9,5	8	14	10	□ 8	20	20	56	117
●	E331080.TQ1001P	106	80	33	30	26	19	13	21,5	11	9	18	9	□ 10	24	20	56	140
●	E331110.TQ1201P	138	110	39	33	29	22	14	22	12	11	18	11	□ 12	28	21	66	177
●	E331140.TQ1401P	174	140	49	41	35	34	16	25,5	13,5	15	22	19	□ 14	30	23	76	267
●	E331185.TQ1701P	220	185	55	45	40	40	16,5	26,5	14	16,5	28	21	□ 17	34	25	86	400

## CRANK HANDLE WITH SQUARE HOLE - REVOLVING HANDLE M129

# E332

	Art.	L	R	H	D	d	m	c	A	B	h	d3	h3	d1 H10	Q	dl	L1	Δg
●	E332065.TQ0601P	88	65	30	27	22	17	13	18	9,5	8	14	10	□ 6	20	20	56	101
●	E332065.TQ0801P	88	65	30	27	22	17	13	18	9,5	8	14	10	□ 8	20	20	56	107
●	E332080.TQ1001P	106	80	33	30	26	19	13	21,5	11	9	18	9	□ 10	24	20	56	130
●	E332110.TQ1201P	138	110	39	33	29	22	14	22	12	11	18	11	□ 12	28	21	66	167
●	E332140.TQ1401P	174	140	49	41	35	34	16	25,5	13,5	15	22	19	□ 14	30	23	76	257
●	E332185.TQ1701P	220	185	55	45	40	40	16,5	26,5	14	16,5	28	21	□ 17	34	25	86	390

# E240



## CRANK HANDLE WITH HEXAGONAL HOLE AND REVOLVING AND FOLDING HANDLE

**Material:** Reinforced polyamide. Oils and greases resistant.

**Surface:** Satin.

**Colour:** Black (RAL 9011).

**Central Cap:** Grey polyamide RAL 7035 (cod. 13).

**Alternative Cap Colour:**  
 Orange (RAL 2004 cod. 02)  
 Red (RAL 3000 cod. 16)  
 Blue (RAL 5015 cod. 07)  
 Green (RAL 6024 cod. 17)  
 Yellow (RAL 1021 cod. 10)  
 Black (RAL 9011 cod. 01)

**Main Insert:** Black-oxide treated insert, with hexagonal through-hole, H10 tolerance.

**Side Insert:** Brass right through threaded bush.

**Side Handle:** Revolving and folding handle Art. M136.



### SPECIAL REQUESTS:

- It is possible to supply the inserts in different treatment-finishes, on request and for quantities.
- It is possible to supply arm and handle with colours as shown in the table at pag. 23, on request and for quantities.

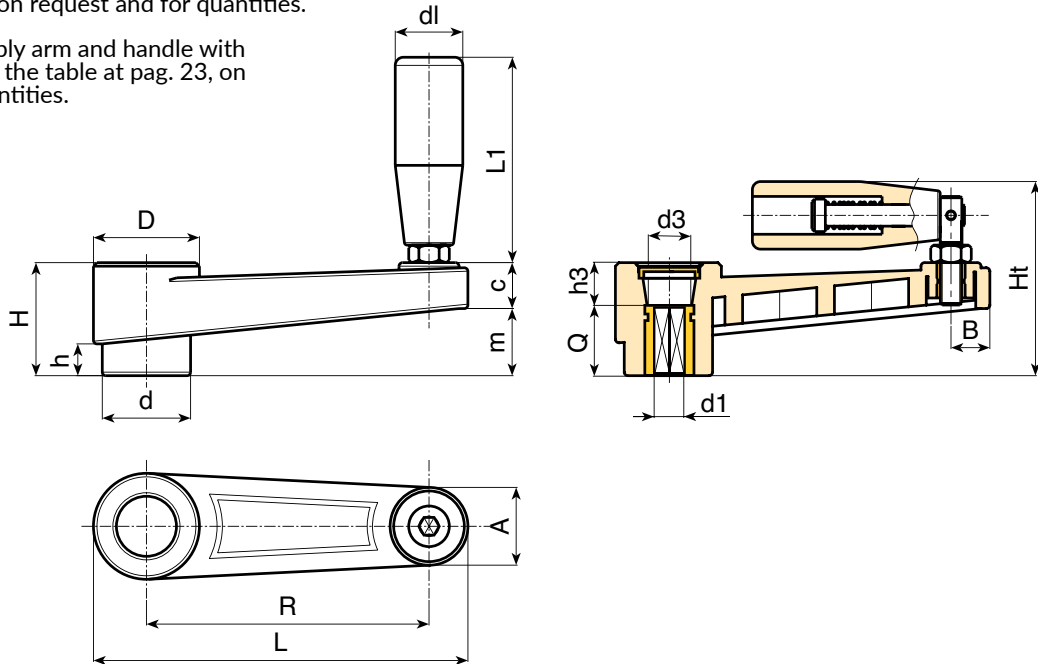

	Art.	L	R	H	Ht	D	d	m	c	A	B	h	d3	h3	d1 H10	Q	dl	L1	△ g
●	E240065.TE0601P	88	65	30	54	27	22	17	13	18	9,5	8	14	10	6	20	20	54	78
●	E240065.TE0801P	88	65	30	54	27	22	17	13	18	9,5	8	14	10	8	20	20	54	78
●	E240080.TE1001P	106	80	33	57	30	26	19	13	21,5	11	9	18	9	10	24	20	54	94
●	E240080.TE1201P	106	80	33	57	30	26	19	13	21,5	11	9	18	9	12	24	20	54	95
●	E240110.TE1201P	138	110	39	67,5	33	29	25	14	22	12	11	18	11	12	28	25	75	156
●	E240110.TE1401P	138	110	39	67,5	33	29	25	14	22	12	11	18	11	14	28	25	75	156
●	E240140.TE1401P	174	140	49	82	41	35	33	16	25,5	13,5	15	22	19	14	30	26	89	274
●	E240140.TE1601P	174	140	49	82	41	35	33	16	25,5	13,5	15	22	19	16	30	26	89	283
●	E240185.TE1601P	220	185	55	88	45	40	40	16,5	26,5	14	16,5	28	21	16	34	26	97	340
●	E240185.TE1701P	220	185	55	88	45	40	40	16,5	26,5	14	16,5	28	21	17	34	26	97	345

# E242



## CRANK HANDLE WITH SQUARE HOLE AND FOLDING HANDLE

**Material:** Reinforced polyamide. Oils and greases resistant.

**Surface:** Satin.

**Colour:** Black (RAL 9011).

**Central Cap:** Grey polyamide RAL 7035 (cod. 13).

**Alternative Cap Colour:**  
 Orange (RAL 2004 cod. 02)  
 Red (RAL 3000 cod. 16)  
 Blue (RAL 5015 cod. 07)  
 Green (RAL 6024 cod. 17)  
 Yellow (RAL 1021 cod. 10)  
 Black (RAL 9011 cod. 01)

**Main Insert:** Black-oxide treated insert, with square through-hole, H10 tolerance.

**Side Insert:** Brass right through threaded bush.

**Side Handle:** Revolving and folding handle Art. M136.



### SPECIAL REQUESTS:

- It is possible to supply the inserts in different treatment-finishes, on request and for quantities.
- It is possible to supply arm and handle with colours as shown in the table at pag. 23, on request and for quantities.

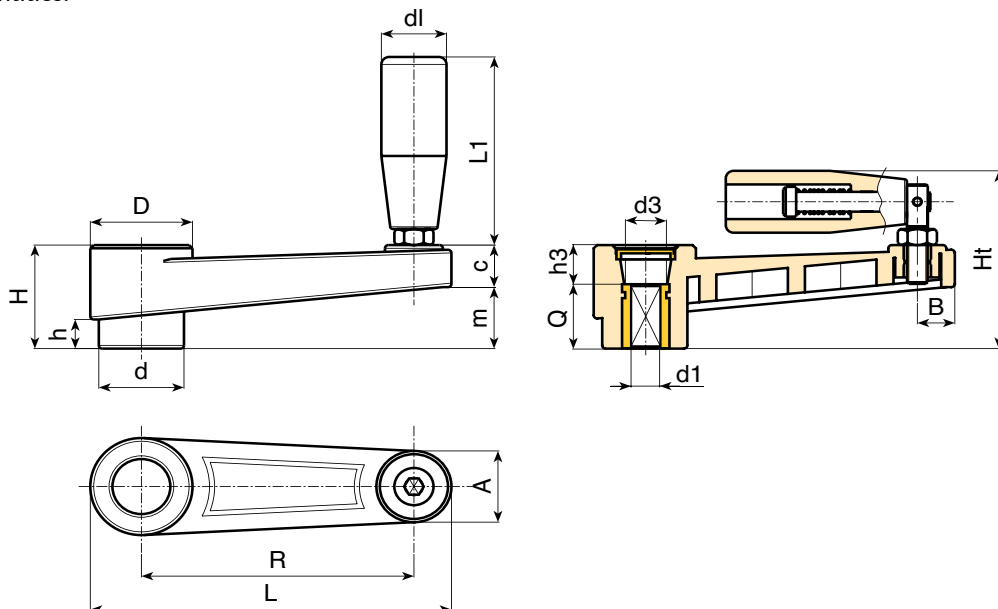

	Art.	L	R	H	Ht	D	d	m	c	A	B	h	d3	h3	d1 H10	Q	dl	L1	
●	E242065.TQ0801P	88	65	30	54	27	22	17	13	18	9,5	8	14	10	□ 8	20	20	54	100
●	E242080.TQ1001P	106	80	33	57	30	26	19	13	21,5	11	9	18	9	□ 10	24	20	54	110
●	E242110.TQ1201P	138	110	39	67,5	33	29	25	14	22	12	11	18	11	□ 12	28	25	75	156
●	E242140.TQ1401P	174	140	49	82	41	35	33	16	25,5	13,5	15	22	19	□ 14	30	26	89	240
●	E242185.TQ1701P	220	185	55	88	45	40	40	16,5	26,5	14	16,5	28	21	□ 17	34	26	97	430

Presumable presence in the stock in %

90% ● 40% ● 5% ●

# E518

## INDEXED CRANK HANDLE WITH THREADED INSERT AND REVOLVING HANDLE

Art. E518

**Material:** Reinforced polyamide. Oils and greases resistant.

**Surface:** Satin.

**Colour:** Black (RAL 9011).

**Main Insert:**  
Zinc plated steel blind threaded bush.

**Side Insert:** Brass right through threaded bush.

**Spring:** Zinc plated steel spring.

**Fixing Screw:**  
Black-oxyde treated screw with head for fitting screwdriver.

**Side Handle:**  
E518: Revolving handle Art. M144  
E513: Revolving handle Art. M145  
E517: Revolving handle Art. M129.

### SPECIAL REQUESTS:

- It is possible to supply the inserts in different materials, on request and for quantities.
- It is possible to supply arm and handle with colours as shown in the table at pag. 23, on request and for quantities.



Art. E517



Art. E513

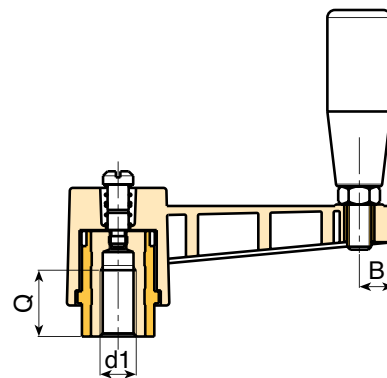
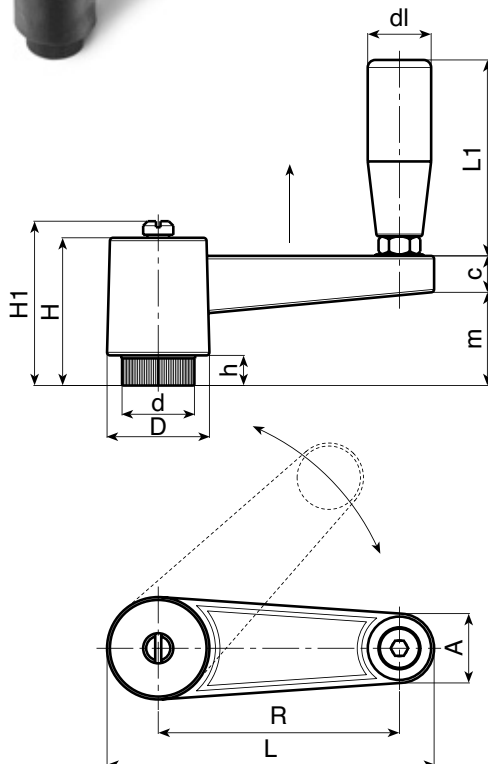





## INDEXED CRANK HANDLE WITH THREADED INSERT AND REVOLVING HANDLE **E518**

	Art.	L	R	H	D	d	m	c	A	B	h	H1	d1 6H	Q	dl	L1	 g
●	E518065.TM0801	86	65	46	27	19	29	13	17	9	10	-	M08	18	20	56	94
●	E518065.TM1001	86	65	46	27	19	29	13	17	9	10	-	M10	17	20	56	90
●	E518065.TM1201	86	65	46	27	19	29	13	17	9	10	-	M12	17	20	56	90
●	E518080.TM1201	108	80	50	34	24	32	13	22	11,5	10,5	53	M12	22	21	66	172
●	E518080.TM1401	108	80	50	34	24	32	13	22	11,5	10,5	53	M14	23	21	66	164
●	E518080.TM1601	108	80	50	34	24	32	13	22	11,5	10,5	53	M16	20	21	66	154
●	E518110.TM1201	138	110	50	34	24,5	33	13	22	11,5	11	54	M12	20	21	66	181
●	E518110.TM1401	138	110	50	34	24,5	33	13	22	11,5	11	54	M14	20	21	66	195
●	E518110.TM1601	138	110	50	34	24,5	33	13	22	11,5	11	54	M16	20	21	66	198

## INDEXED CRANK HANDLE WITH THREADED INSERT - REVOLVING HANDLE M145 - **E513**

	Art.	L	R	H	D	d	m	c	A	B	h	H1	d1 6H	Q	dl	L1	 g
●	E513065.TM0801	86	65	46	27	19	29	13	17	9	10	-	M08	18	20	56	96
●	E513065.TM1001	86	65	46	27	19	29	13	17	9	10	-	M10	17	20	56	92
●	E513065.TM1201	86	65	46	27	19	29	13	17	9	10	-	M12	17	20	56	91
●	E513080.TM1201	108	80	50	34	24,5	32	13	22	11,5	10,5	53	M12	22	23	66	177
●	E513080.TM1401	108	80	50	34	24,5	32	13	22	11,5	10,5	53	M14	23	23	66	179
●	E513080.TM1601	108	80	50	34	24,5	32	13	22	11,5	10,5	53	M16	20	23	66	169
●	E513110.TM1201	138	110	50	34	24,5	33	13	22	11,5	11	54	M12	20	23	66	196
●	E513110.TM1401	138	110	50	34	24,5	33	13	22	11,5	11	54	M14	20	23	66	200
●	E513110.TM1601	138	110	50	34	24,5	33	13	22	11,5	11	54	M16	20	23	66	205

## INDEXED CRANK HANDLE WITH THREADED INSERT - REVOLVING HANDLE M129 - **E517**

	Art.	L	R	H	D	d	m	c	A	B	h	H1	d1 6H	Q	dl	L1	 g
●	E517065.TM0801	86	65	46	27	19	29	13	17	9	9,5	-	M08	18	20	52	106
●	E517065.TM1001	86	65	46	27	19	29	13	17	9	9,5	-	M10	17	20	52	102
●	E517065.TM1201	86	65	46	27	19	29	13	17	9	9,5	-	M12	17	20	52	102
●	E517080.TM1201	108	80	50	34	24,5	32	13	22	11,5	10,5	53	M12	22	23	62	187
●	E517080.TM1401	108	80	50	34	24,5	32	13	22	11,5	10,5	53	M14	23	23	62	189
●	E517080.TM1601	108	80	50	34	24,5	32	13	22	11,5	10,5	53	M16	20	23	62	179
●	E517110.TM1201	138	110	50	34	24,5	33	13	22	11,5	11	54	M12	20	23	62	206
●	E517110.TM1401	138	110	50	34	24,5	33	13	22	11,5	11	54	M14	20	23	62	198
●	E517110.TM1601	138	110	50	34	24,5	33	13	22	11,5	11	54	M16	20	23	62	196

# E519



## INDEXED CRANK HANDLE WITH THREADED INSERT AND REVOLVING AND FOLDING HANDLE

**Material:** Reinforced polyamide. Oils and greases resistant.

**Surface:** Satin.

**Colour:** Black (RAL 9011).

**Main Insert:** Zinc plated steel blind threaded bush.

**Side Insert:** Brass right through threaded bush.

**Spring:** Zinc plated steel spring.

**Fixing Screw:** Black-oxide treated screw with head for fitting screwdriver.

**Side Handle:** Revolving and folding handle Art. M136.



### SPECIAL REQUESTS:

- It is possible to supply the inserts in different materials, on request and for quantities.
- It is possible to supply arm and handle with colours as shown in the table at pag. 23, on request and for quantities.

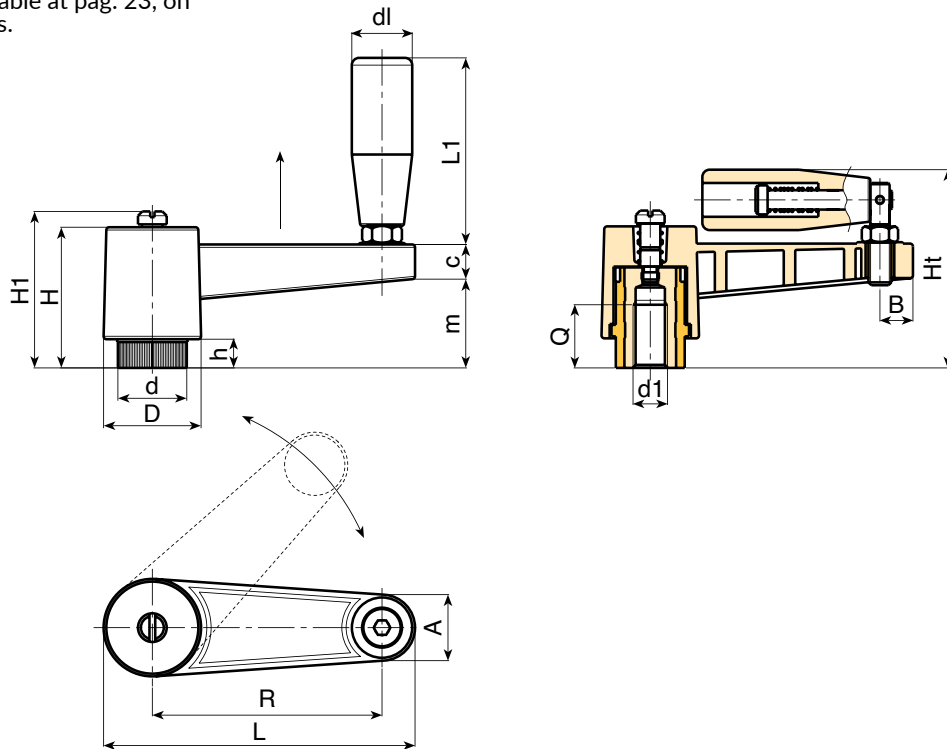

	Art.	L	R	H	D	d	m	c	A	B	h	H1	Ht	d1 6H	Q	dl	L1	g
●	E519065.TM0801	86	65	46	27	19	29	13	17	9	10	-	66,5	M08	18	20	54	104
●	E519065.TM1001	86	65	46	27	19	29	13	17	9	10	-	66,5	M10	17	20	54	102
●	E519065.TM1201	86	65	46	27	19	29	13	17	9	10	-	66,5	M12	17	20	54	100
●	E519080.TM1201	108	80	50	34	24,5	32	13	22	11,5	10,5	53	75	M12	22	25	75	185
●	E519080.TM1401	108	80	50	34	24,5	32	13	22	11,5	10,5	53	75	M14	23	25	75	180
●	E519080.TM1601	108	80	50	34	24,5	32	13	22	11,5	10,5	53	75	M16	20	25	75	174
●	E519110.TM1201	138	110	50	34	24,5	33	13	22	11,5	11	53	75	M12	20	25	75	199
●	E519110.TM1401	138	110	50	34	24,5	33	13	22	11,5	11	53	75	M14	20	25	75	220
●	E519110.TM1601	138	110	50	34	24,5	33	13	22	11,5	11	53	75	M16	20	25	75	225

# E521



## INDEXED CRANK HANDLE WITH SMOOTH INSERT AND REVOLVING AND FOLDING HANDLE

**Material:** Reinforced polyamide. Oils and greases resistant.

**Surface:** Satin.

**Colour:** Black (RAL 9011).

**Main Insert:** Zinc plated steel blind bored bush with H10 tolerance.

**Side Insert:** Brass right through threaded bush.

**Spring:** Zinc plated steel spring.

**Fixing Screw:** Black-oxide treated screw with head for fitting screwdriver.

**Side Handle:** Revolving and folding handle Art. M136.



### SPECIAL REQUESTS:

- It is possible to supply the inserts in different materials, on request and for quantities.
- It is possible to supply arm and handle with colours as shown in the table at pag. 23, on request and for quantities.

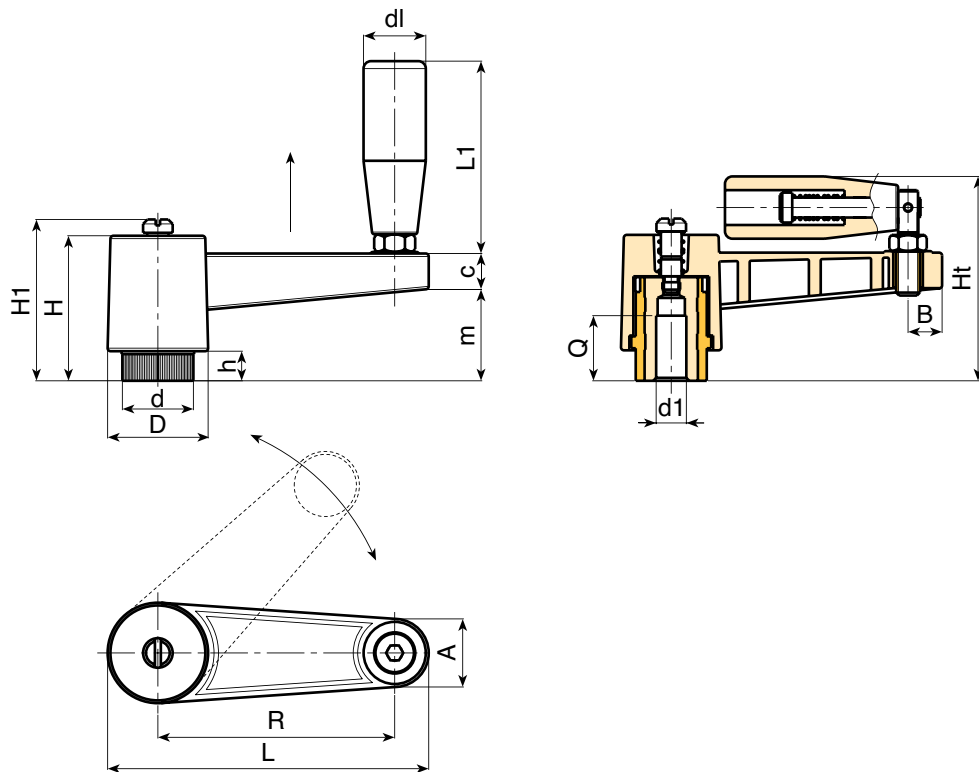

	Art.	L	R	H	D	d	m	c	A	B	h	H1	Ht	d1 H10	Q	dl	L1	⚖ B
●	E521065.TP0501	86	65	46	27	19	29	13	17	9	10	-	66,5	5	22	20	54	105
●	E521080.TP0501	108	80	50	34	24,5	32	13	22	11,5	10,5	53	75	5	24	25	75	190
●	E521110.TP0501	138	110	50	34	24,5	33	13	22	11,5	11	54	75	5	28	25	75	220

# E520

## INDEXED CRANK HANDLE WITH SMOOTH INSERT AND REVOLVING HANDLE

Art. E520

**Material:** Reinforced polyamide. Oils and greases resistant.

**Surface:** Satin.

**Colour:** Black (RAL 9011).

**Main Insert:**

Zinc plated steel blind bored bush with H10 tolerance.

**Side Insert:** Brass right through threaded bush.

**Spring:** Zinc plated steel spring.

**Fixing Screw:**

Black-oxide treated screw with head for fitting screwdriver.

**Side Handle:**

E520: Revolving handle Art. M144

E511: Revolving handle Art. M145

E516: Revolving handle Art. M129.

**SPECIAL REQUESTS:**

- It is possible to supply the inserts in different materials, on request and for quantities.
- It is possible to supply arm and handle with colours as shown in the table at pag. 23, on request and for quantities.



Art. E511



Art. E516

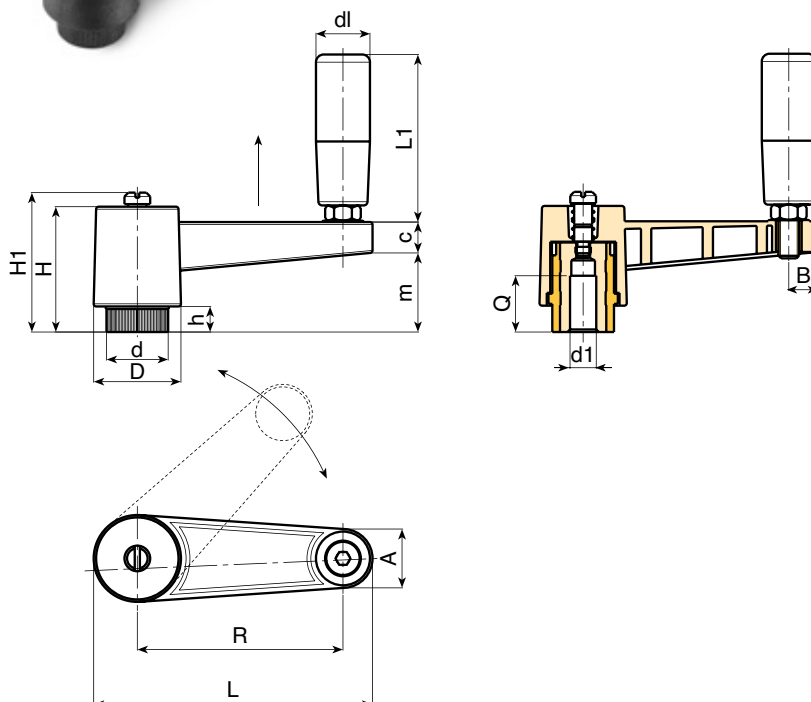



## INDEXED CRANK HANDLE WITH SMOOTH INSERT AND REVOLVING HANDLE

# E520

	Art.	L	R	H	D	d	m	c	A	B	h	H1	d1 H10	Q	dl	L1	 g
●	E520065.TP0501	86	65	46	27	19	29	13	17	9	10	-	5	22	20	56	83
●	E520080.TP0501	108	80	50	34	24,5	32	13	22	11,5	10,5	53	5	24	21,5	66	177
●	E520110.TP0501	138	110	50	34	24,5	33	13	22	11,5	11	54	5	28	21,5	66	200

E

## INDEXED CRANK HANDLE WITH SMOOTH INSERT - REVOLVING HANDLE M145 -

# E511

	Art.	L	R	H	D	d	m	c	A	B	h	H1	d1 H10	Q	dl	L1	 g
●	E511065.TP0501	86	65	46	27	19	29	13	17	9	10	-	5	22	20	56	92
●	E511080.TP0501	108	80	50	34	24,5	32	13	22	11,5	10,5	53	5	24	23	66	187
●	E511110.TP0501	138	110	50	34	24,5	33	13	22	11,5	11	54	5	28	23	66	205

## INDEXED CRANK HANDLE WITH SMOOTH INSERT - REVOLVING HANDLE M129 -









# E516

	Art.	L	R	H	D	d	m	c	A	B	h	H1	d1 H10	Q	dl	L1	 g
●	E516065.TP0501	86	65	46	27	19	29	13	17	9	10	-	5	22	20	52	95
●	E516080.TP0501	108	80	50	34	24,5	32	13	22	11,5	10,5	53	5	24	23	62	197
●	E516110.TP0501	138	110	50	34	24,5	33	13	22	11,5	11	54	5	28	23	62	207

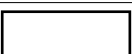

# COLOUR CHART

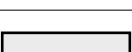
## RAL COLOURS CODING

Colour		RAL	Cod.
Black		9011	01
Orange		2004	02
Orange		2011	03
White		9010	04
Blue		5015	07
Yellow		1007	09
Yellow		1021	10
Grey		7024	12
Grey		7035	13
Red		3000	16
Green		6024	17

E

AUTHORISED RESELLER

**BOTECO Srl**

**[www.boteco.it](http://www.boteco.it)**

36010 ZANE' (VI) - ITALY

Via L. Pettinà 16 ( side street of Via Cuso)

Switchboard Tel.:+39-0445-316411 - Fax:+39-0445-316400

Sales Fax:+39-0445-316401 mail: [commerciale@boteco.it](mailto:commerciale@boteco.it)

Administration Fax:+39-0445-316402 mail: [amministrazione@boteco.it](mailto:amministrazione@boteco.it)

Technical Fax:+39-0445-316404 mail: [tecnico@boteco.it](mailto:tecnico@boteco.it)

**Certified Mail Box: [boteco@pec.botecopec.it](mailto:boteco@pec.botecopec.it)**

