

External Extension Handle

SKU / Product Number

- 500-2310900

Benefits and Features

- Mounts to the outside of a case (rotomold, ATA, etc).
- Extends 12", handle stops in two positions: full extended and fully retracted with locking tab.
- Approximate weight capacity 125lbs.
- Handle has built in offset to glide past extrusions.
- Sides are bevelled to reduce impact.
- Made from glass filled engineered plastic resin.
- Low profile design, with recessed mounting holes (with knock-out cover) to protect screws.

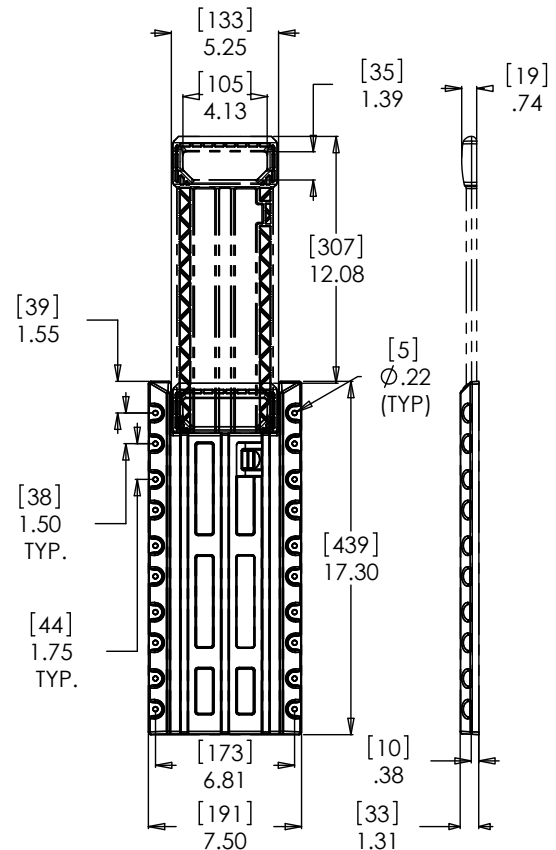

Learn More

To learn more about TCH please contact us toll-free at 1-800-465-6281 to speak to a qualified customer service representative.

Visit our website for a full listing of all TCH products at: tchweb.com.

BUFFALO	CALGARY	DALLAS	MONTRÉAL	TORONTO
1370 William Street Buffalo, NY U.S.A. 14206	1135-45th avenue NE Calgary, AB, Canada T2E 2P2	10552 King William Dr. Dallas, TX U.S.A. 75220	16757 Boul. Hymus Kirkland, QC Canada H9H 3L4	40 Emblem Court Toronto, ON Canada M1S 1B1