

# Light Weight Handle

## SKU / Part Number

- 500-101900

## Benefits and Features

- Steel retainer plate gives strong support to the bail.
- Securing mounting rivets through the steel retainer provides a sturdy connection to the case.
- Molded grip for comfort.
- Dish is made of light weight engineered plastic.
- Handle made with 1/4" steel bail for strength.
- 25% less weight of a comparable steel handle.
- Complements TCH composite panels, lightweight latch 501-5711900 and corner 502-1460900.



## Learn More

To learn more about TCH, please contact us toll-free at 1-800-465-6281 to speak to a qualified customer service representative.

Please visit our website for a full listing of TCH products at [tchweb.com](http://tchweb.com).

## Matching Products



## Spec Drawing

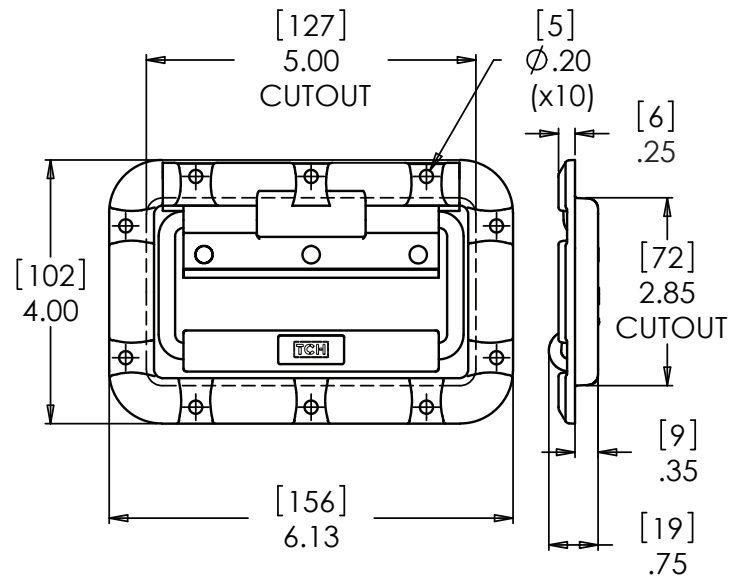

Latch: 501-5711900 | Ball Corner: 502-1460900

BUFFALO	CALGARY	DALLAS	MONTRÉAL	TORONTO
1370 William Street Buffalo, NY U.S.A. 14206	1135-45th avenue NE Calgary, AB, Canada T2E 2P2	10552 King William Dr. Dallas, TX U.S.A. 75220	16757 Boul. Hymus Kirkland, QC Canada H9H 3L4	40 Emblem Court Toronto, ON Canada M1S 1B1