

USER'S MANUAL

∞ ONE CONTROL

Caiman Tail Loop
150 Presets MIDI 5PC/CC with Tap Tempo Switcher

- Features

- 150 presets(PGM), 5 PGMs / bank, 30 banks.
- Each PGM contain 5 groups of PC# and 5 CC# midi messages.
- Buffer/Non-Buffer input options.
- 5 loops and 2 footswitches (Latch/Momentary options).
- Easy PGM programming, Direct mode allows user to control loops on the fly.
- Independent mute switch.

Front View

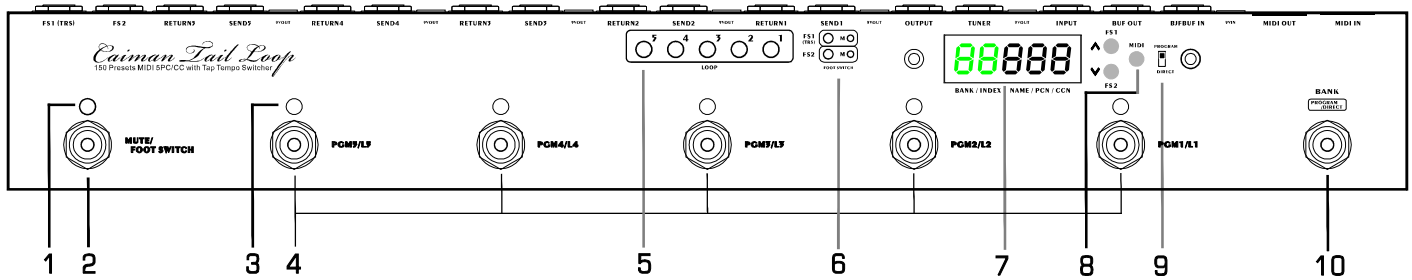

1. MUTE INDICATOR

The indicator lights on when the switcher is muted.

2. MUTE

Engage MUTE footswitch will mute OUTPUT and switch the INPUT to TUNER jack.

3. PGM(1~5) INDICATOR

The indicator lights on when a PGM is engaged.

4. PGM1/L1 ~ PGM5/L5

In Recall mode, these switches recall the settings stored PGMs, and the status LED lights on. In Program/Direct mode, the switches directly engage/bypass loop1~5.

5. LOOP(1~5) INDICATOR

The indicator lights on when LOOP(1~5) is engaged.

6. FOOTSWITCH(FS1/FS2) INDICATOR

The indicator lights on when FS1/ FS2 is latched.

7. SCREEN

The Screen shows all the information as bank index, PGM name, or midi messages etc.

8. FS/MIDI/SETUP BUTTONS

These buttons are for footswitch edit, MIDI PC#/CC# edit and initialization setup.

9. PROGRAM/DIRECT SWITCH

When edit a PGM, the changes of loop and footswitch (FS1/FS2) will be saved when the switch is at PROGRAM position, while not saved at DIRECT position.

10. BANK / (PROGRAM/DIRECT)

Click this switch to change the bank number (1~5).

Hold to change the lane number (A~F).

Double click to edit a PGM (PROGRAM/DIRECT).

Rear View

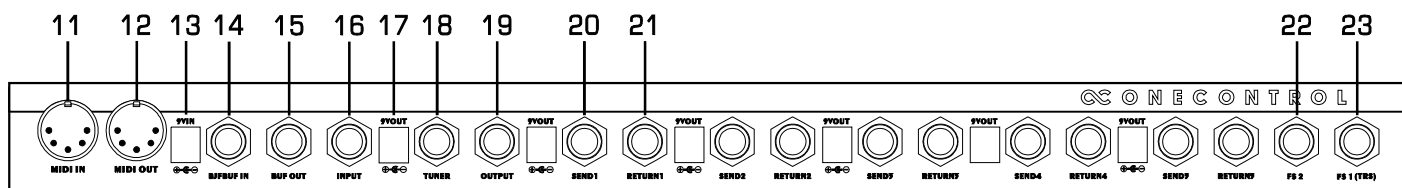

11. MIDI IN

This jack receive midi messages.

12. MIDI OUT

This jack transmit midi messages.

13. 9V IN

Connect DC 9V power source here, negative center, 5.5 x 2.1mm type.

14. BJF BUF IN

Signal input from this jack is fed to BJF buffer prior to being sent to the loops.

15. BUF OUT

BJF buffered signal outputs via this jack.

16. INPUT

Non-buffer input jack.

17. 9V OUT

There are six 9V OUT jacks which are daisy chain of 9V IN, the total absolutely maximum output current of these jacks is 2500mA.

18. TUNER

This jack will connect to INPUT jack when the MUTE footswitch is engaged.

19. OUTPUT

The input signal via buffered or non-buffered Input jack reaches OUTPUT jack via loop1~5.

20. SEND(1~5)

These are the send jacks of loops 1~5. Connect these jacks to the inputs of guitar pedals.

21. RETURN(1~5)

These are the return jacks for loops 1~5. Connect these jacks to the outputs of guitar pedals.

22. FS2

Footswitch 2, latch type/momentary.

23. FS1(TRS)

Footswitch 1, latch type/momentary, FS1 is a TRS type jack, the ring of FS1 connects to the tip of FS2, DO NOT insert cable in FS2 jack if FS1 is used as a TRS footswitch.

- Signal Path

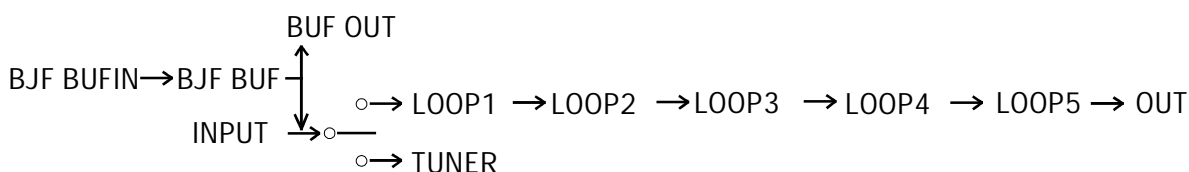

- PGM Hierarchy

There are total 150 PGMs which are contained in 30 banks(A1 ~F5).

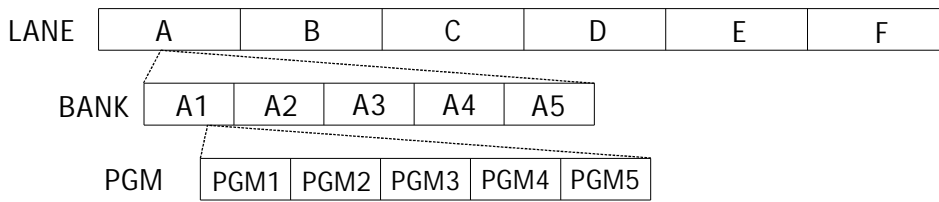

- Recall a PGM

In RECALL mode, user can recall stored presets by pressing PGM switches, the corresponding indicator will light up when a PGM is engaged, the SCREEN show the bank information and the PGM name. The 30 banks are divided into 6 lanes (A~F), each lane have 5 banks (1~5), clicking BANK once to scroll up the numbers and hold BANK switch for 2 seconds to start the lane change.



Example 1
Bank : A1
PGM name : Pub



Example 2
Bank : C5
PGM name : R66

- Edit a PGM

Double click BANK switch will enter EDIT mode and the SCREEN will show "PGM" (Program) or "DCT" (Direct). In EDIT mode, user's able to edit Loop1~5, footswitches and midi value.

Edit loop1~5: By clicking PGM1/L1~PGM5/L5 switch.

Edit FS1/FS2: By clicking button FS1/FS2.

Edit MIDI: Hold "MIDI" button for 2 seconds to start midi edit, each PGM contain 5 groups of PC#(1~5) and CC#(1~5) working on midi channel 1~5, use button "^" (UP) and "v" (DOWN) to edit the numbers, when a PC# or CC# edit is finished, press button "MIDI" once to start edit of the next PC# or CC#.

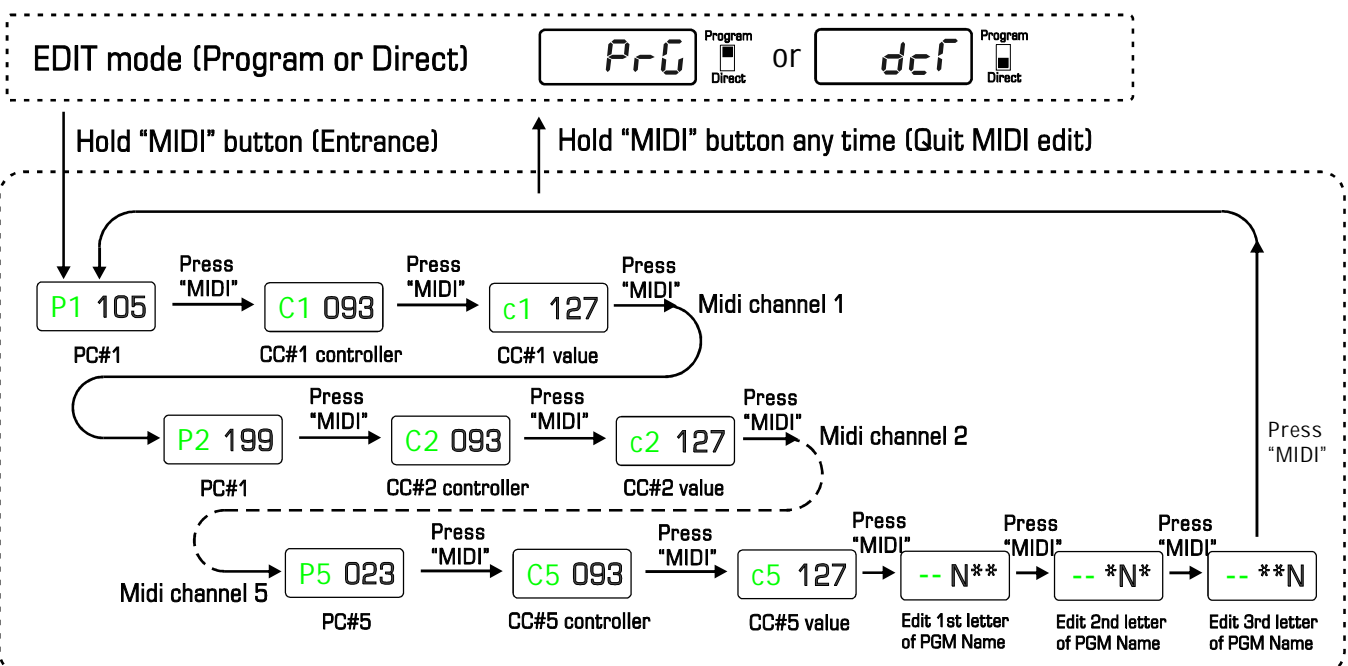

Holding "UP"/"DOWN" button can continuously scrolling up/down the number to speed up the edits. When the PROGRAM/DIRECT toggle is at PROGRAM position, the changes (loop1 ~5, FS1/FS2) will be saved immediately while the changes will be discarded if the toggle switch is at DIRECT position. The MIDI changes will be always saved even when the toggle switch is at DIRECT position. Click BANK switch any time Caiman will quit to RECALL mode from EDIT mode.

Each PGM has name which can be edited. In MIDI edit mode, follow the last group of PC#/CC#, the 3-letters name could be edited, user can use 10 numbers and "A~Z" letters to name each PGM.

- FOOTSWITCH FS1 / FS2

There are two footswitch jacks, FS1 and FS2, usually they are used as "latch" type to switch amplifier channels, user can edit FS1/FS2 as "normal open" or "normal close" in a PGM. In the factory setting FS1/FS2 are both "latch" type. In EDIT mode, the FS1/FS2 type is showed on the green display, "L" is latch type.

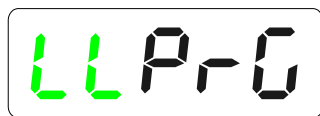

FS1 FS2

FS1: Latch type, FS2: Latch type

FS1/FS2 can also be configured as "momentary" type to control some special amplifiers, or as tap tempo input of some vintage ambient pedals.

FS1/FS2 can be set as "normal open (momentary close)" - display "u", or "normal close (momentary open)" - display "n". In a PGM, user can edit a momentary footswitch "enabled" or "disabled" by pressing button FS1/FS2, "enabled" allows a momentary trigger of the footswitch when a PGM is recalled, "disabled" - nothing changes on the footswitch when a PGM is recalled.

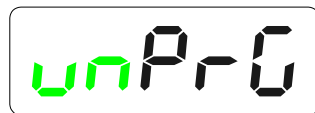

FS1 FS2

FS1 : Normal open/Momentary close

FS2 : Normal close/Momentary open

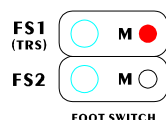

FS1 : Momentary enabled in a PGM

FS2 : Momentary disabled in a PGM

FOOT SWITCH

When a footswitch jack is set as momentary type and "enabled", every press on a PGM will generate a momentary trigger on this footswitch jack, this function allows user to control a momentary type footswitch amplifier or as tap tempo input of some vintage ambient pedals.

- MIDI Channel

Caiman transmits midi messages on 5 channels, each PGM contain 5 groups of PC#/CC#. PC#1/CC#1 work on midi channel 1, PC#2/CC#2 on channel 2..... and so on, the midi channel are not editable, however, each channel could be turned on/off, when a midi channel is turned off, the related PC#/CC# will not be transmitted and not be displayed in a PGM.

- Pre Engage CC#

The Pre Engage CC# is a Control Change number which is transmitted before PC#/CC# on each channel.

Transmission sequence: Pre CC#1 - PC#1 - CC#1 - Pre CC#2 - PC#2 - CC#2.....

The Pre CC# is designed to engage a bypassed midi guitar pedal before it does a patch change, the Pre CC# is a midi controller number with range "0~127", or "off", the value of Pre CC# is fixed "127", not editable, for example, if Pre CC#1 is assigned with "102", it always transmits 102(controller)/127(value) on midi channel 1.

Scenario:

Caiman works with a Strymon Timeline which is working on MIDI channel 1, the Timeline MIDI input is connected to Caiman's MIDI output, the audio path of Timeline is directly connected to amplifier's send/return loop (not though any loop of Caiman), one PGM of Caiman is recalled, it bypass the Timeline by sending CC#1 "102/0", then another PGM is recalled, it expects to do a patch change (PC#1) then volume boost (CC#1) on Timeline and effect immediately, Timeline changes the patch and volume boosted but it only has dry sound because it is still bypassed, the Pre engage CC# is to solve such issue, assign Pre engage CC#1 "102", this PGM will send "102/127" to engage Timeline to bring the effect firstly then make patch change and volume boost.

- MIDI Through

Caiman have MIDI input and output jacks, when MIDI is set to "Through", the MIDI output jack transmits the messages received from MIDI input jack.

- Factory Reset

The Factory Reset erase all the PGM memories (loop/footswitch/MIDI/names) and assign PGM with factory setting.

- Initialization Setup

The InitSetup allows user to initialize

- Footswitch (FS1/FS2) type.
- Midi channel 1~5 on/off.
- Pre CC# setup.
- MIDI through enable/disable.
- Factory reset.

When Caiman is standby after any PGM is recalled, hold “MIDI” button for 2s, It enters init Setup and the screen shows “SETUP”, the init setup operates in a menu structure. Below diagram gives a detail illustration.

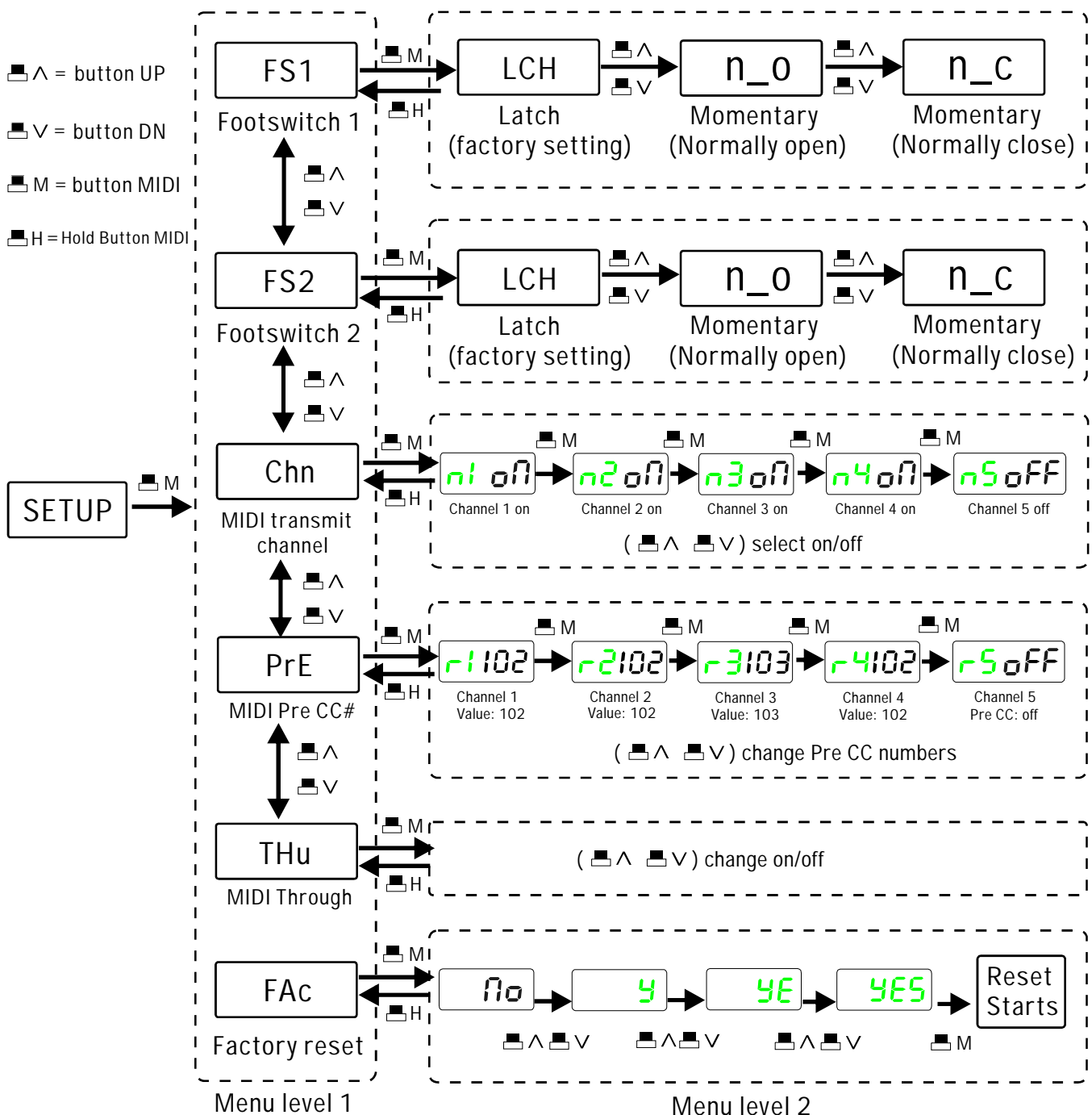

- Specifications

Dimensions.....440(L) x 58(W) x 50(H) mm
 Power Supply.....DC9V
 Current Drain.....max. 220mA
 Max. Buffered Input Vp-p..... 5V
 Max. Non-Buffered Input Vp-p..... 30V

Typical Connection

