

---

**ESSENZIALED®**

Led Lighting | [www.essenzialed.com](http://www.essenzialed.com)



**Virus**

A I R P U R I F I E R

A I R C L E A N I N G

A I R D E O D O R I Z A T I O N

---

T E C H N O L O G Y

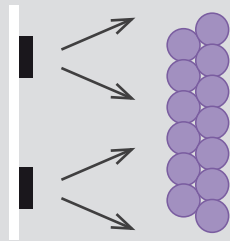

UV-A  
LIGHT

PHOTO  
CATALYST  
TITANIUM  
DIOXIDE



HYDROXYL  
RADICALS  
FORMED



VIRUS,  
BIOAEROSOLS,  
SMELLS, BACTERIA  
AND POLLUTANTS



ATTACKING  
HARMFUL  
SUBSTANCES



DESTRUCTION OR  
DECOMPOSITION OF  
SUBSTANCES

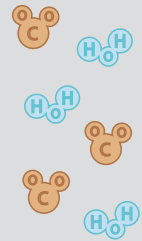

BYPRODUCT  
HARMLESS  
 $H_2O$  AND  $CO_2$

WHAT DESTROYS



VIRUS

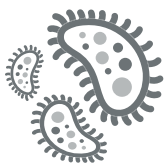

BACTERIA

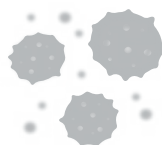

FUNGUS & MOLD



DUST & ALLERGENS



DANGEROUS GAS



CIGARETTE SMOKE



VOC



SMELLS

WHAT DETECTS



AIR QUALITY



CARBON MONOXIDE

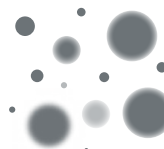

PM 10



VOC



HUMIDITY



INFLAMMABLE SUBSTANCES



TEMPERATURE

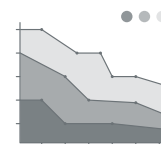

DATA & STATISTICS

V E R S I O N S



T R A C K



R E C E S S E D



W A L L & C E I L I N G



T A B L E

FINISHING & DETAILS

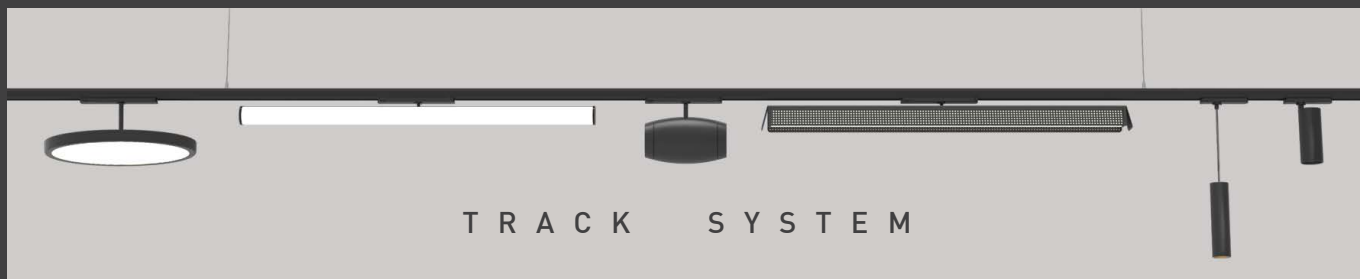
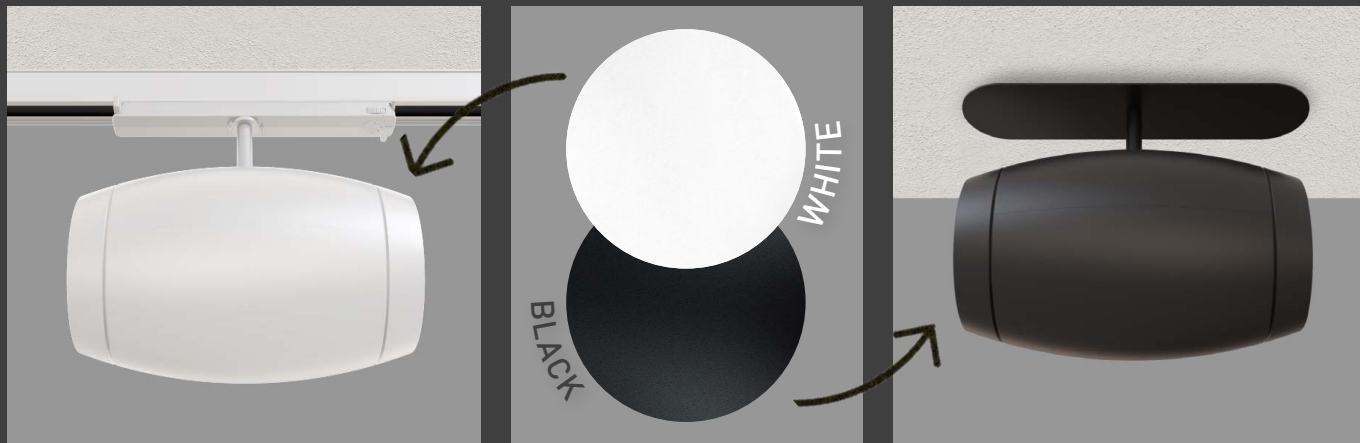

M A T E R I A L S

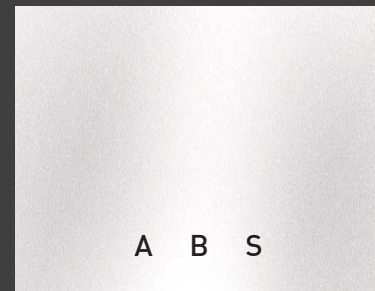

A B S

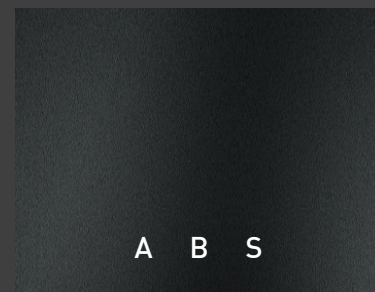

A B S

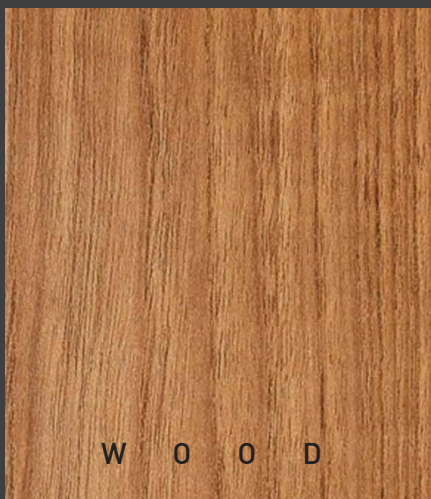

W O O D



# T R A C K

SUITABLE FOR THE FOLLOWING TRACKS: NA GLOBALTRAC PRO, CONCORD, EUTRAC 25101, HOFFMEISTER, IG STD 677, IVELA, STUCCHI, UNIPRO T3

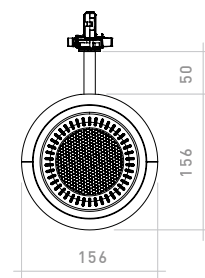
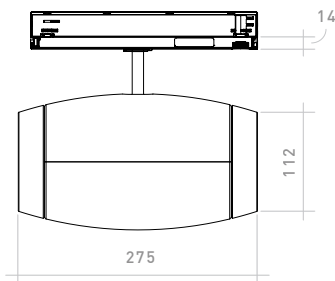

	PURE VERSION	SMART VERSION	Premium VERSION
AIR FLOW	126 m <sup>3</sup> /h	126 m <sup>3</sup> /h	126 m <sup>3</sup> /h
APP DEVICE	✗	iOS & ANDROID	iOS & ANDROID
IOT 4.0	✗	✓	✓
SMART CONTROL	✗	CASAMBI 🗲	CASAMBI 🗲
FILTERS	PRE-FILTER (DUST CAPTURE) TiO2 FILTERS + UV-A LED	PRE-FILTER (DUST CAPTURE) TiO2 FILTERS + UV-A LED	PRE-FILTER (DUST CAPTURE) TiO2 FILTERS + UV-A LED
NOISE	from 15 dBa to 50 dBa	from 15 dBa to 50 dBa	from 15 dBa to 50 dBa
RATED VOLTAGE	220 ÷ 240 Vac	220 ÷ 240 Vac	220 ÷ 240 Vac
POWER CONSUMPTION	40 W	40 W	40 W
ROOM COVERAGE	150 m <sup>2</sup> *	150 m <sup>2</sup> *	150 m <sup>2</sup> *
AIR QUALITY SENSOR	✗	TEMPERATURE - HUMIDITY PRESSURE - VOC	TEMPERATURE - HUMIDITY PRESSURE - VOC INFLAMMABLE GAS- PM10

\* The flow rate is indicative, as it varies according to the type of environment / ventilation present.  
The data shown refers to an open space (ceiling 3m / h) and with forced ventilation (e.g. shops / offices)

# R E C E S S E D



CUT-OUT HOLE: 300 x 50 mm

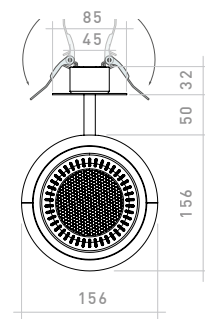
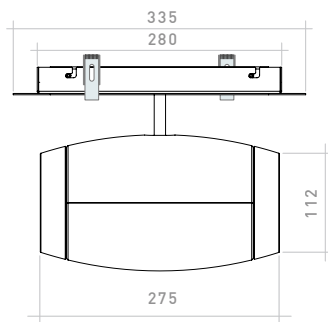

	PURE VERSION	SMART VERSION	Premium VERSION
AIR FLOW	126 m <sup>3</sup> /h	126 m <sup>3</sup> /h	126 m <sup>3</sup> /h
APP DEVICE	✗	iOS & ANDROID	iOS & ANDROID
IOT 4.0	✗	✓	✓
SMART CONTROL	✗	CASAMBI 🗲	CASAMBI 🗲
FILTERS	PRE-FILTER (DUST CAPTURE) TiO2 FILTERS + UV-A LED	PRE-FILTER (DUST CAPTURE) TiO2 FILTERS + UV-A LED	PRE-FILTER (DUST CAPTURE) TiO2 FILTERS + UV-A LED
NOISE	from 15 dBa to 50 dBa	from 15 dBa to 50 dBa	from 15 dBa to 50 dBa
RATED VOLTAGE	220 ÷ 240 Vac	220 ÷ 240 Vac	220 ÷ 240 Vac
POWER CONSUMPTION	40 W	40 W	40 W
ROOM COVERAGE	150 m <sup>2</sup> *	150 m <sup>2</sup> *	150 m <sup>2</sup> *
AIR QUALITY SENSOR	✗	TEMPERATURE - HUMIDITY PRESSURE - VOC	TEMPERATURE - HUMIDITY PRESSURE - VOC INFLAMMABLE GAS- PM10

\* The flow rate is indicative, as it varies according to the type of environment / ventilation present.  
The data shown refers to an open space (ceiling 3m / h) and with forced ventilation (e.g. shops / offices)



# W A L L & C E I L I N G

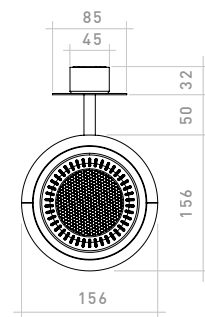
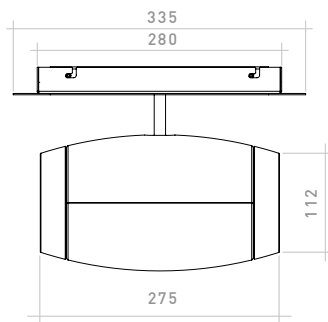

AIR FLOW
APP DEVICE
IOT 4.0
SMART CONTROL
FILTERS
NOISE
RATED VOLTAGE
POWER CONSUMPTION
ROOM COVERAGE
AIR QUALITY SENSOR

<b>PURE</b> VERSION
126 m³/h
✗
✗
✗
PRE-FILTER (DUST CAPTURE) TiO2 FILTERS + UV-A LED
from 15 dBa to 50 dBa
220 ÷ 240 Vac
40 W
150 m²*
✗

<b>SMART</b> VERSION
126 m³/h
iOS & ANDROID
✓
CASAMBI 📶
PRE-FILTER (DUST CAPTURE) TiO2 FILTERS + UV-A LED
from 15 dBa to 50 dBa
220 ÷ 240 Vac
40 W
150 m²*
TEMPERATURE - HUMIDITY PRESSURE - VOC

<i>Premium</i> VERSION
126 m³/h
iOS & ANDROID
✓
CASAMBI 📶
PRE-FILTER (DUST CAPTURE) TiO2 FILTERS + UV-A LED
from 15 dBa to 50 dBa
220 ÷ 240 Vac
40 W
150 m²*
TEMPERATURE - HUMIDITY PRESSURE - VOC INFLAMMABLE GAS- PM10

\* The flow rate is indicative, as it varies according to the type of environment / ventilation present.  
The data shown refers to an open space (ceiling 3m / h) and with forced ventilation (e.g. shops / offices)

T A B L E

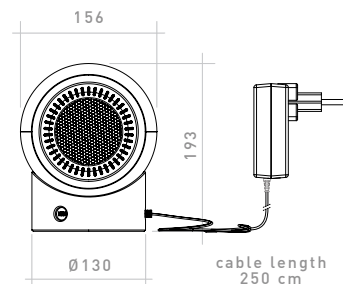
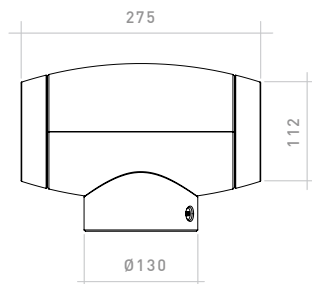

	SMART VERSION	Premium VERSION
AIR FLOW	126 m <sup>3</sup> /h	126 m <sup>3</sup> /h
APP DEVICE	iOS & ANDROID	iOS & ANDROID
IOT 4.0	✓	✓
SMART CONTROL	CASAMBI ⚠	CASAMBI ⚠
TOUCH ON / OFF - SELECT MODE	✓	✓
FILTERS	PRE-FILTER (DUST CAPTURE) TiO <sub>2</sub> FILTERS + UV-A LED	PRE-FILTER (DUST CAPTURE) TiO <sub>2</sub> FILTERS + UV-A LED
NOISE	from 15 dBa to 50 dBa	from 15 dBa to 50 dBa
RATED VOLTAGE	110 ÷ 240 Vac	110 ÷ 240 Vac
POWER CONSUMPTION	40 W	40 W
ROOM COVERAGE	80 m <sup>2</sup> *	80 m <sup>2</sup> *
AIR QUALITY SENSOR	TEMPERATURE - HUMIDITY PRESSURE - VOC	TEMPERATURE - HUMIDITY PRESSURE - VOC INFLAMMABLE GAS- PM10

\* The flow rate is indicative, as it varies according to the type of environment / ventilation present.

# CASAMBI APP

## DATA, CHECK & STATISTICS LIVE

- STATUS DEVICE
- TVOC
- PM 10
- HUMIDITY
- PRESSURE
- TEMPERATURE
- LOW POWER GAS
- INFLAMMABLE GAS



## REMOTE CONTROL\* & HISTORY REPORTS

- AIR QUALITY DATA REPORTS
- DEVICE REMOTE CONTROL
- EXPORT OF STATISTICAL DATA



## CONTROL & REGULATION

- SCENARIOS
- AIR FLOW
- TIMER
- UP TO 200 DEVICES



\* Remote control available with gateway internet connection.

**ESSENZIALED®**

Led Lighting | [www.essenzialed.com](http://www.essenzialed.com)

---

ESSENZIALED lighting division - Bertronic srl  
Via Silvio Pellico 26 • Stezzano (BG) • Italy  
+39 035 592363 • [info@vairusair.it](mailto:info@vairusair.it)  
[www.vairusair.it](http://www.vairusair.it)