

## TRED-E-CSB-2A

Technical Datasheet for wireless Trailing-Edge Dimming unit for LED Lighting



### Description

The TRED-E-CSB-2A is a Trailing Edge Dimmer with Casambi integration.

TRED-E-CSB-2A provides dimming and is typically used with incandescent light sources, retrofit LED lamps, electronic transformers and LED drivers that are compatible with Trailing Edge Phase Dimming.

- Trailing Edge Dimming controller
- Capable of loads up to 2A
- Casambi Enabled
- Bluetooth Beacons



## Technical Specifications

### Mechanical

Housing	Black Plastic Injection Moulded ABS
Dimensions	103mm x 35mm x 28mm
Weight	50g
Protection	IP20
Mounting	Screwdown

### Input

Voltage Range	120-277VAC
Frequency	50-60Hz
Max. Mains Current	2A (3A Fused)
No-load Standby Power	<300mW

### Output

Dimming Method	Trailing-Edge Phase Control
Dimming Output	Logarithmic/Linear, 0-100%, 0.4% Resolution
Max Output Power	Tungsten or Halogen lamps = 460W@230VAC/240W@120VAC Dimmable LED and CFL lamps= 150W@230VAC /75W@120VAC Trailing Edge LED drivers, Electronic Transformers = 150W@230VAC/75W@120VAC  <i>Note: Not compatible with magnetic/inductive loads such as iron core transformers. This will permanently damage the TRED. Do not mix load types.</i>
Max Output Current	2A
Min. Load Requirement	1W
Max Inrush Current	30A

### Radio Transceiver

Operating Frequencies	2.4Ghz - 2.483Ghz
Maximum Output Power	+4dBm
Wireless Protocol	Bluetooth Low Energy v4.1

### Operating Conditions

Ambient Temperature	0°C to +50°C
Max. Case Temperature	+75°C
Storage Temperature	-40°C to +80°C
Max. Relative Humidity	80% non-condensing

### Connectors

Wire Range, Solid	0.2mm - 2.5mm
Wire Strip Length	5mm

## Dimensions

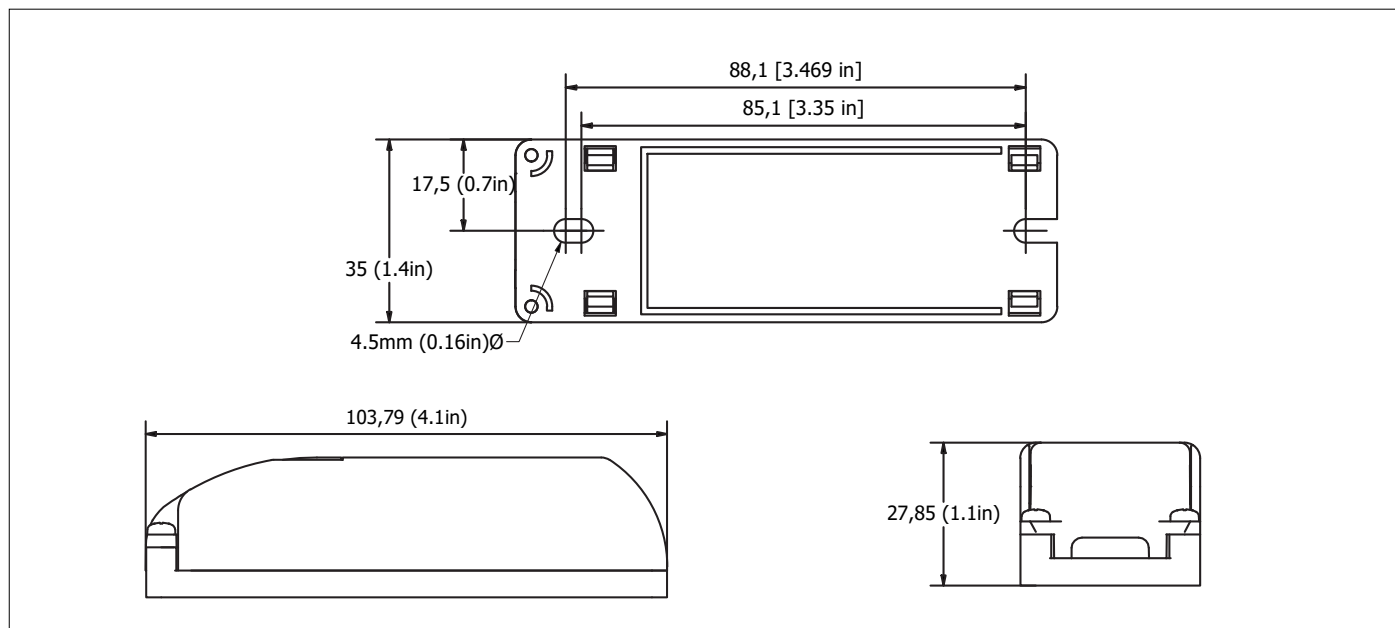

## Wiring Diagram

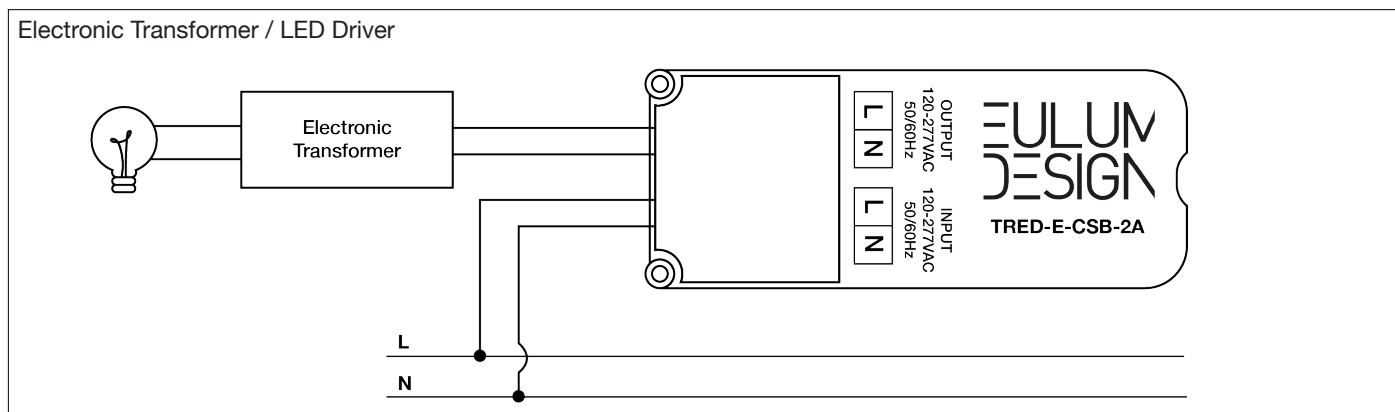
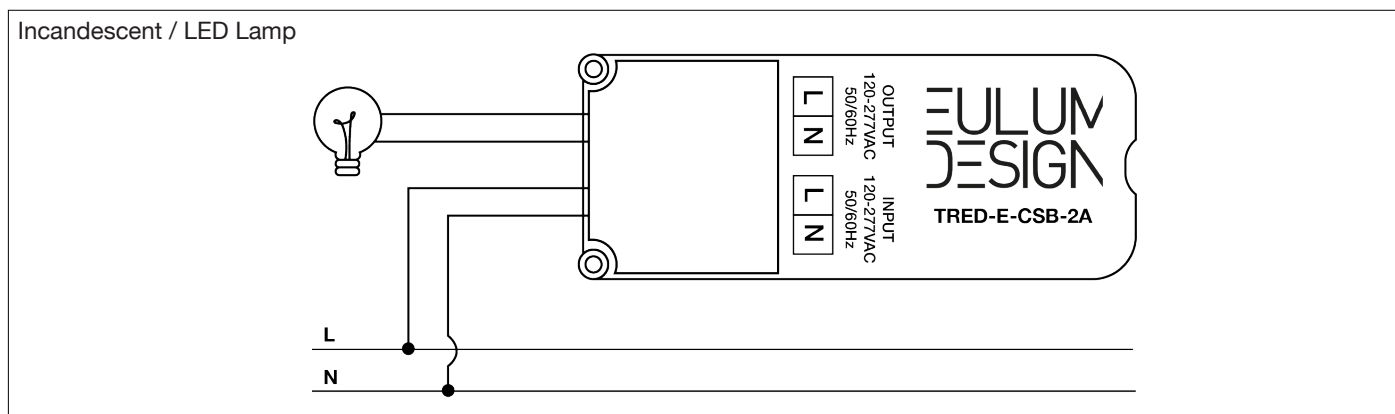

## Profiles

Profile Name	Description
TRED-E-CSB-2A	Trailing Edge Dimmer - Incandescent Profile
TRED-E-CSB-2A(LIN)	Trailing Edge Dimmer - Linear Profile
TRED-E-CSB-2A(LOG)	Trailing Edge Dimmer - Logarithmic Profile
Version	Classic/Evolution

## Calibration

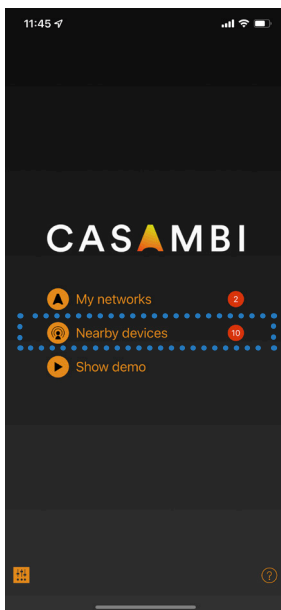

1. Power on the device and open the Casambi App, select “Nearby devices”.

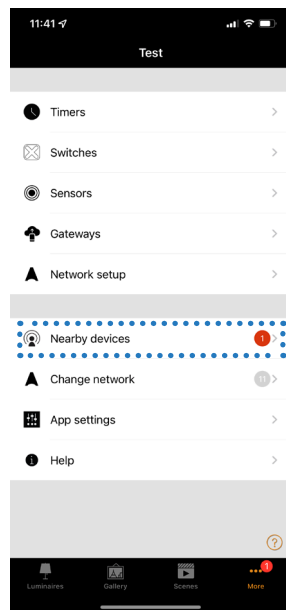

2. Tap “Nearby Devices”

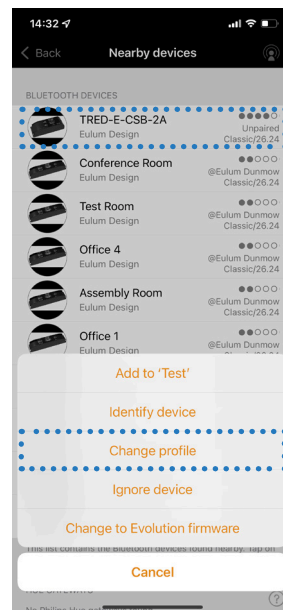

2. Tap the TRED and then “Change profile”.

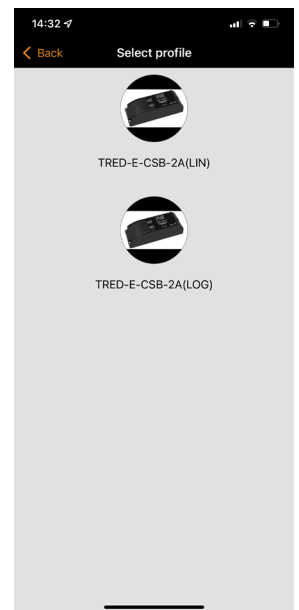

4. Choose your desired profile. TRED-E-CSB-2A is the standard profile and will not show.

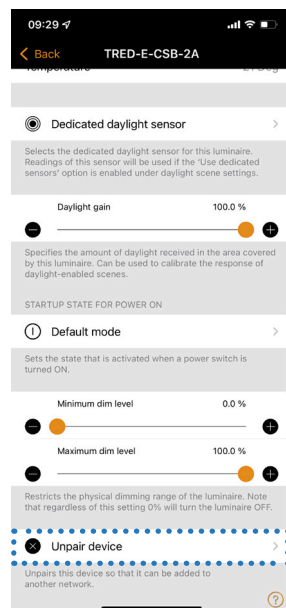
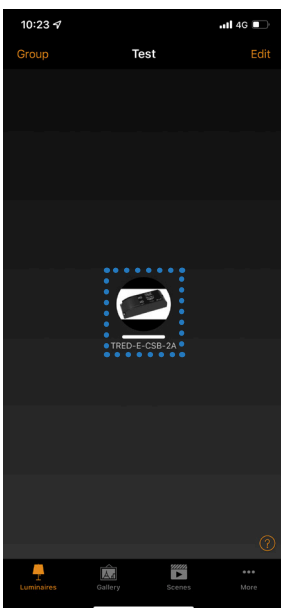

NOTE: The TRED must be unpaired to change the profile. To unpair, double tap the TRED in the network and scroll to the bottom of the options to “Unpair Device”, then follow step on from Step 1 above.

## Range

In open air, the bluetooth range can reach up to 75m. This will be reduced when placed inside a building. Please note that putting the bluetooth unit inside a metal enclosure is unadvised as this will dramatically reduce the signal range.

## Compatible Devices:

iPhone iOS and later are supported  
iPad iOS 10 and later are supported  
Android 4.4 version (KitKat) and later are supported.



## Warranty

For information on our warranty, please visit: [www.eulum.com/warranty/](http://www.eulum.com/warranty/)