

- Smallest DALI module directly powered by 100-240VAC
- 2 DALI-BUSES, driving capability up to 15 DALI members each.
- Smallest power consumption 2 Watts max.
- Simply operate with Casambi.

The DALI module LIGA.AIR.DALI.1T.PICO.240 is directly controlled by the Casambi app.

The module is directly connected to 100-240VAC line voltage.

It contains 2 separate DALI networks, which can be loaded with up to 30mA or up to 15 DALI-members each.

The module is encapsulated in a gray housing with the dimensions (T x B x H) 80 x 27 x 21mm.

The extremely compact housing design allows e.g. easy installation in a cable duct.

#### Dimensional drawing:

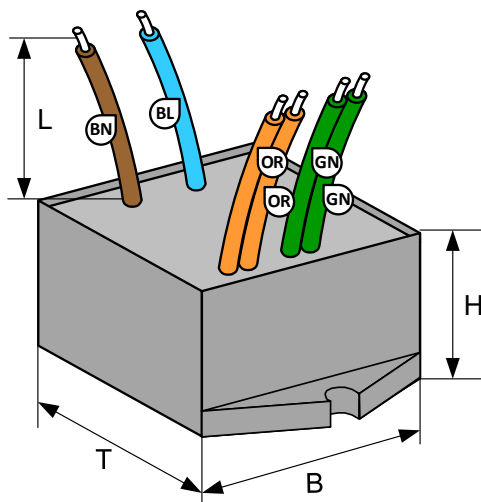

#### Schematics:

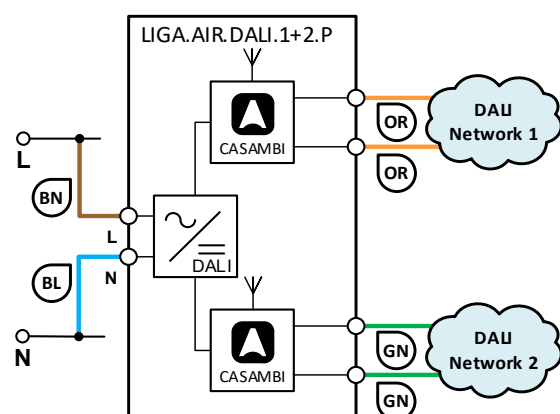

**Installation only by a professional electrician according to the local regulations!**

**Technical specifications:**

Dimension (T x B x H)	61 x 27 x 21mm
Weight	65g
Color	Enclosure schwarz
Mounting	In flush-mounted boxes or cable ducts etc.
Environmental conditions	Operation: Temperature -20 ... 50°C, humidity < 85%rH Stock: Temperature -25 ... 65°C, humidity < 95%rH
Protection type / Protection class	IP64, EN-60529 / Appliance Class II
Connections Power	Flexible 2x 1mm <sup>2</sup> (AWG17), L = 150mm: Brown (BN): L, phase conductor, Blue (BL): N, neutral conductor
Connections DALI output	Flexible 4x 0.5mm <sup>2</sup> (AWG20), L = 150mm: Orange (OR) 2x: DALI1, 17V / 30mA max. (for approx. 15 Dali members) Green (GN) 2x: DALI2, 17V / 30mA max. (for approx. 15 Dali members)
Power supply ratings	100-240V~, 50-60Hz
Power consumption	2 Watts max
Standards	Low Voltage Directive (LVD) 2014/35/EU, EN 60669-2-1 Electromagnetic compatibility (EMC) 2014/30/EU
CASAMBI Modul Standards	Bluetooth 4.0 Wireless Control
Dimming and switching	Settable by the Casambi application (App Store, Google Play)
Applications	Dimming and switching of DALI devices, 1 channel or broadcast
Scope of delivery	1 DALI module

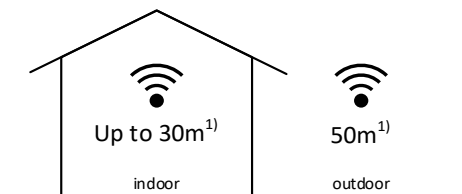
**Compatible devices:****Range:****iPhone 4S** or later**iPad 3** or later**iPod Touch 5th gen** or later.**Android 4.4 KitKat** or later devices

produced after 2013 with full BT 4.0 support.

Casambi uses mesh network technology so each CBU-ASD acts also as a repeater.

Longer ranges can be achieved by using multiple Casambi units.

Range is highly dependent on the surrounding and obstacles, such as walls and building materials.

