

CYCLE UBE E750

DUAL FUNCTION - UPPER ARM CYCLE & LOWER BODY RECUMBENT

The E750 Cycle UBE (Upper Body Ergometer) is a high-quality commercial grade machine that offers maximum operational versatility, including recumbent cycling and bidirectional seated or standing upper body arm cycling. The E750 is fitted with a dual functioning pedal cage with foot straps and ergonomically designed handles for upper body use.

The E750 resistance is set via our 10 levels of Adjustable Fluid Resistance patented Twin Tank system and the RPM is driven by you. The E750 will remain silky smooth and consistent at very low RPM and is capable of handling the ballistic speeds of a HIIT workout. This wide variation in load and speed capabilities allows you to train effectively to any workout program.

If required the low profile seat swivels 90 degrees to aid entry and exit, this unique feature is ideal for deconditioned and rehabilitation exercisers starting on their fitness journey.

The E750 provides options to engage virtually every muscle group, targets strength, builds endurance, rebuilds stability, flexibility and balance.



ROTATING SEAT FOR ENTRY AND EXIT



RECUMBENT CYCLE



SEATED UPPER BODY



STANDING UPPER BODY



FLUID EXERCISE

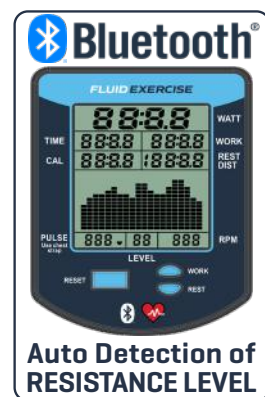

Auto Detection of RESISTANCE LEVEL

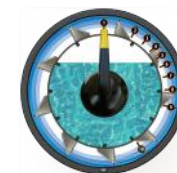

MINIMUM



10
ADJUSTABLE FLUID
RESISTANCE
LEVELS



MAXIMUM

BLACK
FRAME

Lumbar Support

90 degree seat rotation for easy entry and exit

10 Levels of Fluid Resistance

Bluetooth monitor

Arm is counter balanced for easy 360 degree rotation

Cycle pedals

Hand grips

Steel frame

Handles for additional stability.

View the full range of Arm Cycles at [FLUIDEXERCISE.COM](https://www.fluidexercise.com)
Visit [FDFLIMITED.COM](https://www.fdflimited.com) to view all FDF products ranges.

CYCLE UBE E750 FLUIDEXERCISE

PRODUCT SPECIFICATIONS

PRODUCT MODEL NO:	E750
FLUID RESISTANCE:	Vertical FDF Twin Tank - 10 levels
MONITOR:	FDF  Bluetooth / Heart Rate Compatible
PRODUCT NET WEIGHT:	101.4kg [223.5lb]
PRODUCT GROSS WEIGHT:	120.8kg [266.3lb]
DIMENSIONS:	L 1,330mm [52.36"] x W 970mm [38.19"] x H 1,520mm [59.84"]
MIN ACTIVE AREA REQUIRED:	L 1,980mm [77.95"] x W 1,620mm [63.79"]
MAX USER WEIGHT:	150kg [330lb]
ARM CRANK LENGTH:	185mm [7.3"]
LOW SEAT HEIGHT:	540mm [21.3"]
COMMERCIAL WARRANTY:	Frame 10 years - Fluid Tank 5 years Mechanical and all other non wearing components - 2 years



CONSOLE FEATURES

- +  Bluetooth Connectivity
- + Auto start
- + Time - Elapsed time
- + Level - Auto to selected resistance level
- + Watt - Unit of power
- + RPM - Revolutions per minute
- + Power Graphs - 2 Options
- + Heart rate - Polar compatible
- + Calories burned per hour



SEAT ROTATED FOR EASY ENTRY AND EXIT



ROTATING SEAT HANDLE



WINDOW TO READ DEGREE OF ARM ROTATION



COMBO CYCLE PEDALS AND HAND GRIPS

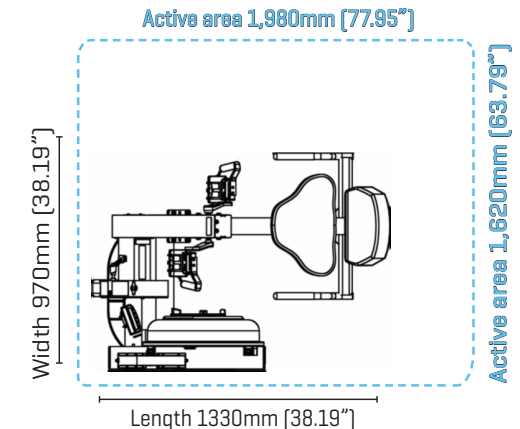

ABOUT FDF LIMITED

FDF Limited is the leader in designing and manufacturing a range of adjustable Fluid Resistance fitness machines for commercial and residential applications. At the heart of the fitness range is the unique and patented Twin Tank Fluid Resistance system. The adjustable Fluid Resistance system challenged conventional thinking of how water could work to provide adjustable resistance rather than just a liquid mass flywheel. The patented Twin Tank system provides silky smooth resistance at any speed and is perfect for cardio training, warm-ups, cool downs, intense HIIT workouts or rehabilitation programs. **FDF Limited** categorizes the range of adjustable Fluid Resistance machines under the banners, **FluidRower**, **FluidExercise** and **FluidPowerZone**, see the adjacent web links. **FDF Limited** products are distributed throughout the globe and are popular in Fitness Centers, Hotels and Apartments, Sporting Clubs, Universities, First Responders, Defence Force Training Facilities and Physical Rehabilitation Clinics.

* FDF reserves the right to modify any product design, manufacture or aesthetic without notice or consultation. Product specifications and warranties may vary from country to country.



View all product ranges at
FLUIDROWER.com

FLUIDEXERCISE.com
FLUIDPOWERZONE.com

FLUIDROWER



FLUIDPOWERZONE



FLUIDEXERCISE

