

Wilo-Stratos MAXO

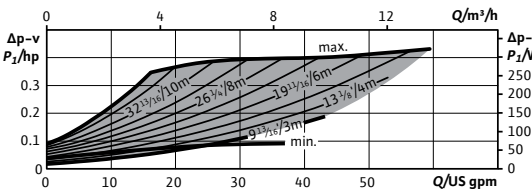

Project:	
Engineer:	
Contractor:	
Submitted By:	Date:
Approved By:	Date:

Tag #	Model #	Flow	Head	Control Mode	Cycle	Phase	Voltage
	Maxo 1.25x3-35				60Hz	1~	115/230-240V

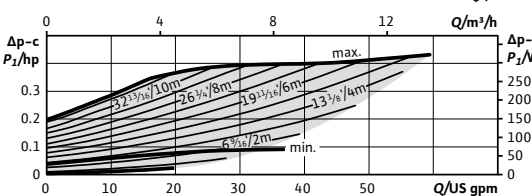
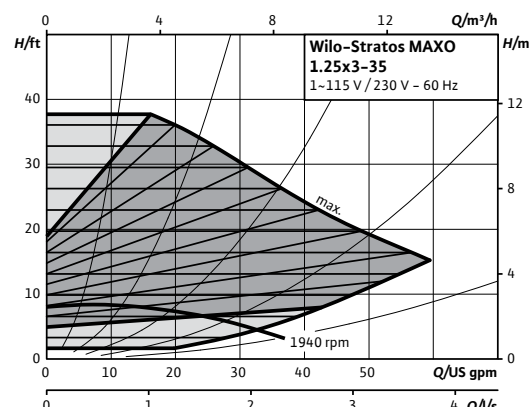
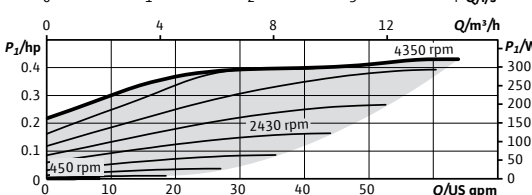
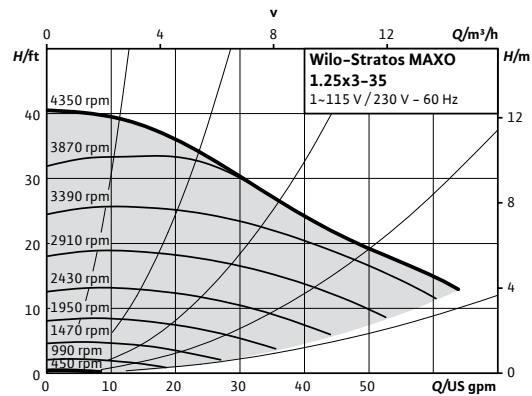

Product Info

Brand	Wilo
Product Description	Stratos MAXO 1.25x3-35
Article Number	2164610
Net Weight (approx.)	34 lbs

Hydraulic Data

Max Operating Pressure PN	145 PSI
Min. Suction Head (122°F)	4.3 PSI
Min. Suction Head (203°F)	14.2 PSI
Min. Suction Head (230°F)	22.8 PSI
Min. Fluid Temp.	14°F
Max Fluid Temp.	230°F
Min. Ambient Temp	14°F
Max. Ambient Temp	104°F

CIF Module Selection

BACnet MS/TP	<input type="checkbox"/>
Modbus RTU	<input type="checkbox"/>
CANopen	<input type="checkbox"/>
LON TP/FT-10	<input type="checkbox"/>
PLR	<input type="checkbox"/>

Accessory Selection

Immersion Temp. Sensor Pt 1000 AA	<input type="checkbox"/>
Immersion Sleeve G 1/2", 45mm	<input type="checkbox"/>
Pipe Surface Contact Sensor PT 1000 B	<input type="checkbox"/>
Immersion Sleeve G 1/2", 100mm	<input type="checkbox"/>

Materials

Pump Housing	EN-GJL-250
Impeller	PPS-GF40
Shaft	X30Cr13
Bearing	Carbon, antimony-impregnated

Motor Data

Mains Connection	1-115V ±10%, 50/60Hz 1-230-240V ±10%, 50/60Hz
Motor Type	ECM
Rated Power P ₂	0.354 hp
Min. Speed n _{min}	450 RPM
Max. Speed n _{max}	4350 RPM
Power Consumption P _{3,max}	0.433 hp
Power Consumption P _{1,min}	0.013 hp
Max Current (1-230V) I _{max}	1.38 A
Min Current (1-230V) I _{min}	0.15 A
Max Current (1-115V) I _{max}	2.83 A
Min Current (1-115V) I _{min}	0.15 A
Insulation Class	F
Protection Class	Enclosure 2

Electrical Inputs

Analog Inputs (2x)	0-10V / 0-20mA / 4-20mA / PT 1000 Passive/Active +24V DC
Digital Inputs (2x)	Ext Off / Ext Min / Ext Max / Ext. MANUAL (BMS off) / External Key Lock / Switch heating, cooling
Wilo NET	Multi-Pump Communication
SSM	Fault Signal
SBM	Run Signal

Installation Dimensions

Pipe Connection (discharge)	1 1/4"
Pipe Connection (suction)	1 1/4"
Flange to Flange	8 1/2"

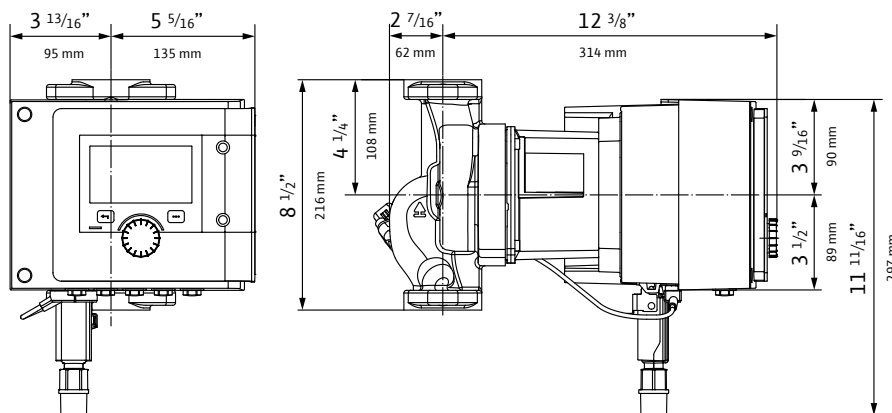
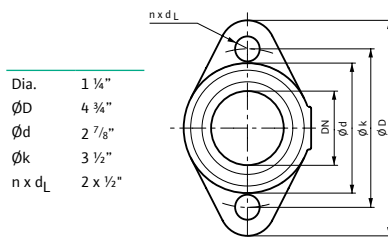

WILO USA LLC
+1 262 204-6600
www.wilo-usa.com
info.us@wilo.com

WILO Canada Inc.
+1 403 276-9456
www.wilo-canada.com
info@wilo-canada.com

WILO Mexico
+52 442 167 00 32
www.wilo-mexico.com
info@wilo.com.mx