



428 Jones Boulevard Phone: (610)495-5131
 Limerick Airport Business Center Fax: (610)495-5134
 Pottstown, PA 19464 www.watsonmcdaniel.com

SERIES WD900S THERMODYNAMIC STEAM TRAP INSTALLATION INSTRUCTIONS

INSTRUCTION PART NO. 2259600 REVISION 5

HOW IT WORKS

The Thermodynamic steam trap cycles periodically to discharge condensate very near to steam temperature.

It is unaffected by waterhammer or superheat.
 An insulating cover minimizes the effect of ambient conditions.

INSTALLATION

The trap will operate in any position, but the preferred installation is in a horizontal pipe with the insulating cover up.

Install the trap with the flow direction as indicated on the body.

Before installing the trap, blow out piping to remove all scale and dirt. Install isolation valves upstream & downstream of the trap.

Inlet and outlet plping must be large enough to handle condensate flow.

Arrange plping to provide gravity flow to the trap.

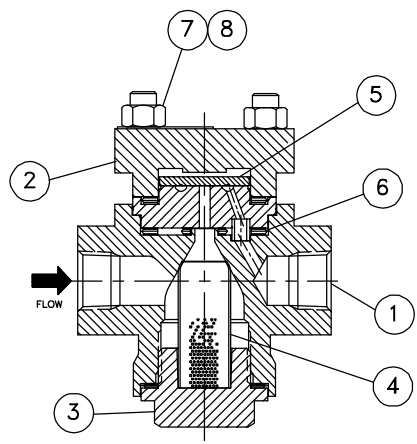

- 1. BODY ALLOY STEEL, GR WC9
SEAT 420S
- 2. COVER ALLOY STEEL, GR WC9
- 3. STRAINER CAP. ALLOY STEEL, GR WC9
- 4. STRAINER 300 SERIES SS
- 5. DISC 420 SS
- 6. GASKET 304 SS
- 7. STUDS SA-193, GR B7
- 8. NUTS SA-194, GR 2H

MAINTENANCE INSTRUCTIONS

Isolate trap from both supply and return line pressures.

Wait until trap can be comfortably touched by hand before any servicing is performed.

The trap should be disassembled periodically for cleaning of the strainer screen and inspection and cleaning of the disc and seat.

To clean disc and seat remove cover and wipe disc and seat surfaces with cleaning solvent.
 CAUTION: Never use any abrasives on disc or seating surface.

If replacement of the seat & disc capsule is necessary, specify kit number W-KIT-900-SDA.

To clean the strainer remove strainer cap and strainer and rinse strainer of any accumulated debris.

Reassemble: Torque strainer cap to 70 ft-lbs and cover nuts to 50 ft-lbs.

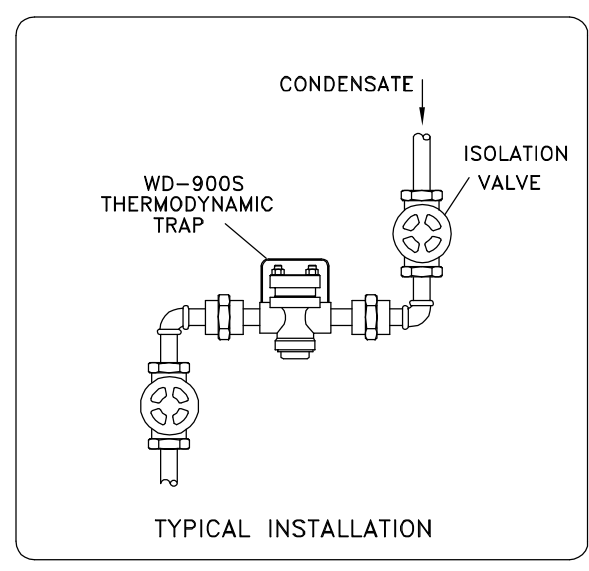

MAX. OPERATING CONDITIONS

- PMO 900 PSIG
- PMA 1500 PSIG @ 100°F
- TMO 842°F
- TMA 842°F @ 981 PSIG

Each Watson McDaniel Company Product is warranted against defects in material and workmanship for one year from date of shipment. This warranty extends to the first retail purchaser only. All defective material must be returned to the person from whom you purchased the Product, transportation prepaid, free of any liens or encumbrances, and if found to be defective will be repaired free of charge or replaced, at the warrantor's or seller's option. If the material is replaced, any replacement will be invoiced in the usual manner and after inspection of alleged defective material an adjustment will be made for depreciation caused by purchaser's use. In no event will Watson McDaniel Company be liable to do more than refund the original contract price. Incidental and consequential damages are excluded, whether under this warranty or otherwise. All implied warranties, including warranties of merchantability and fitness for a particular purpose, are disclaimed and excluded.



Remove trap from line.



Remove cover nuts & cover.



Inspect & clean disc.



Inspect gaskets.



Clean seat with soft rag.



Remove strainer cap.



Inspect strainer cap gasket.



Inspect and clean strainer.



Blow any debris from body.

Reassemble after cleaning and inspecting all parts. Replace gaskets as necessary. Run a soap bubble test with low pressure air to confirm all seals are good before reinstalling in service.