

Model	TD900S, TD900LS
Sizes	1/2", 3/4", 1"
Connections	NPT, SW, 600# FLG
Body Material	Low Carbon Chrome-Moly
Options	Insulation Cap
PMO Max. Operating Pressure	900 PSIG
TMO Max. Operating Temperature	842°F
PMA Max. Allowable Pressure	1500 PSIG @ 100°F
TMA Max. Allowable Temperature	842°F @ 981 PSIG



Typical Applications

DRIP: TD900S model steam traps, capable of handling pressures up to 900 PSIG, are used in drip applications such as draining condensate from steam mains and steam supply lines. The complete internal working mechanism can be replaced while the trap body remains connected in-line. All models contain an integral strainer for protection against dirt and scale. These traps are suitable for outdoor applications that are subject to freezing as well as superheated steam conditions.

How It Works

The disc is the only moving part inside a thermodynamic trap. When steam enters the trap, it creates an internal pressure above the disc that instantly forces the disc to close tightly on the seat, preventing the steam from escaping. The internal steam pressure (holding the disc and seat shut) eventually drops, and the trap re-opens. When condensate enters the trap, it pushes the disc upwards, allowing the condensate to freely discharge. If steam is present, the trap instantly shuts.

Features

- "Quick-Change" seat and disc for easy in-line repair
- High pressure applications up to 900 PSIG
- Integral strainer to protect trap from contamination
- Hardened stainless steel seat and disc for extended service life even at extremely high pressures
- Single trap model will operate over the entire pressure range (20-900 PSIG)
- Suitable for superheated steam
- Freeze-proof when trap is piped in a vertical orientation for complete drainage of condensate
- Trap will function in any orientation (horizontal preferred)

Sample Specification

The steam trap shall be a thermodynamic style with body material in chrome-moly alloy steel. Available in size 1/2", 3/4" and 1" Class 600 socket weld ends or flanges. Unit shall have hardened stainless steel seat and disc with a removable stainless steel strainer.

Installation and Maintenance

The TD900S can be installed in any orientation; however, horizontal with cap facing upward is preferred for longest service life. For maintenance, ALL internal components are easily removed and completely changed using a replacement kit. All models contain an integral strainer for protection against dirt and scale. Available in NPT, Socket-Weld and Flange connections.

Helpful Selection Information

The TD900LS is a reduced capacity version of the standard TD900S model. The TD900S is available in NPT, Socket Weld, and Flange connections from 1/2" thru 1".

Options

Customized Flanged Connections: Specify size and face-to-face dimensions.

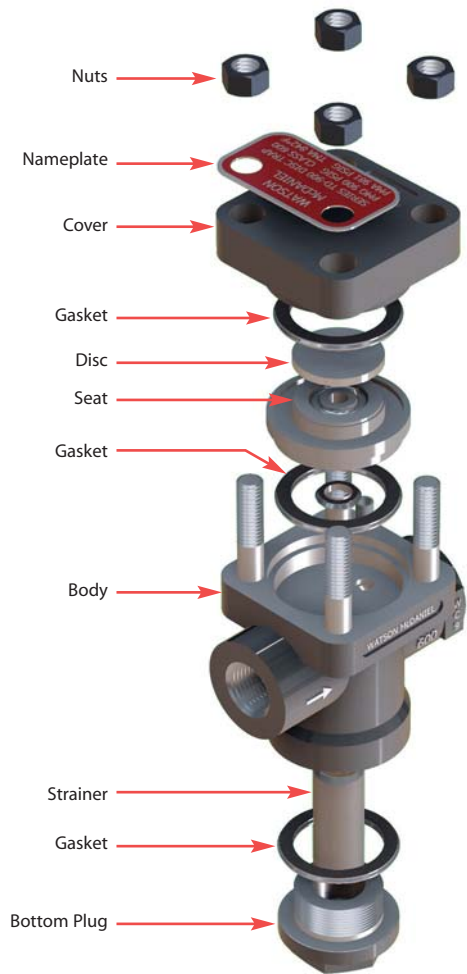

Complete internal working mechanism can be replaced while trap body remains connected in-line

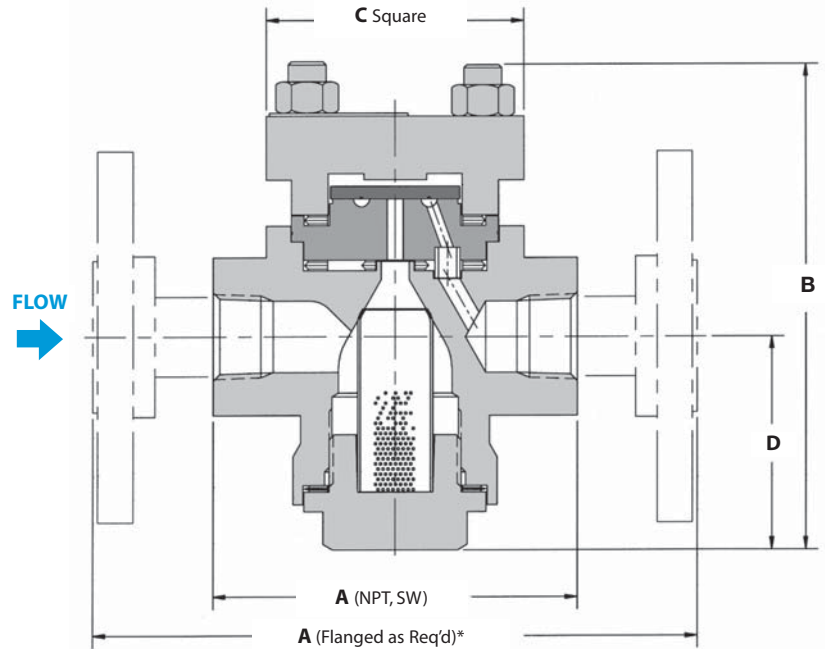

* Flanged face-to-face dimension 9" standard. For custom sizes consult factory (9" minimum).

DIMENSIONS & WEIGHTS – inches

Size	Model	Connection	A	B	C	D	Weight (lbs)
1/2"	TD900S/TD900LS	NPT, SW	3.6	4.8	2.6	2.1	4.5
		*600# FLG	9.0	4.8	2.6	2.1	9.0
3/4"	TD900S/TD900LS	NPT, SW	3.6	4.8	2.6	2.1	4.5
		*600# FLG	9.0	4.8	2.6	2.1	11.0
1"	TD900S/TD900LS	NPT, SW	6.5	4.8	2.6	2.1	4.5
		*600# FLG	9.0	4.8	2.6	2.1	11.0

MATERIALS

Body	Alloy Steel, GR WC9
Seat	Stainless Steel, AISI 420
Cover	Alloy Steel, GR WC9
Strainer Cap	Alloy Steel, GR WC9
Strainer	Stainless Steel, AISI 300
Disc	Stainless Steel, AISI 420
Gasket	Stainless Steel, AISI 304
Studs	SA-193, GR B7
Nuts	SA-194, GR 2H

CAPACITIES – Condensate (lbs/hr)

Size	Model Code (NPT)	Model Code (SW)	Steam Inlet Pressure (PSIG)													
			20	50	100	150	200	300	400	500	600	700	800	900		
1/2"	TD900S-12-N	TD900S-12-SW														
3/4"	TD900S-13-N	TD900S-13-SW	243	411	555	641	700	781	835	874	905	930	951	968		
1"	TD900S-14-N	TD900S-14-SW														
1/2"	TD900LS-12-N	TD900LS-12-SW														
3/4"	TD900LS-13-N	TD900LS-13-SW				181	210	253	290	325	360	381	405	429		
1"	TD900LS-14-N	TD900LS-14-SW														

Notes: WD900S: 1) Minimum recommended working pressure: 20 PSIG.
2) Maximum back pressure not to exceed 80% of inlet pressure (measured in absolute pressure) or trap may not close.

WD900LS: 1) Minimum recommended working pressure: 150 PSIG.
2) Maximum back pressure not to exceed 50% of inlet pressure (measured in absolute pressure) or trap may not close.