

**COMPETITOR REPLACEMENT
 SERIES - SP TYPE D PILOT FOR
 E SERIES MAIN VALVE
 INSTALLATION INSTRUCTIONS**

INSTRUCTION PART NO. 2525500

REVISION 0

TYPE D SERIES PRESSURE REDUCING PILOT

This pilot is a direct replacement for SP Type D Pilots and offers additional design features, such as:

- Easily field-replaceable head and seat cartridge assembly of hardened stainless steel
- Quick-change, long-lasting bronze diaphragms
- 60 mesh screen for protection of the head and seat
- SP Type D tubing kit will match this pilot

Designed for downstream pressure control accuracy of ± 1 psig.

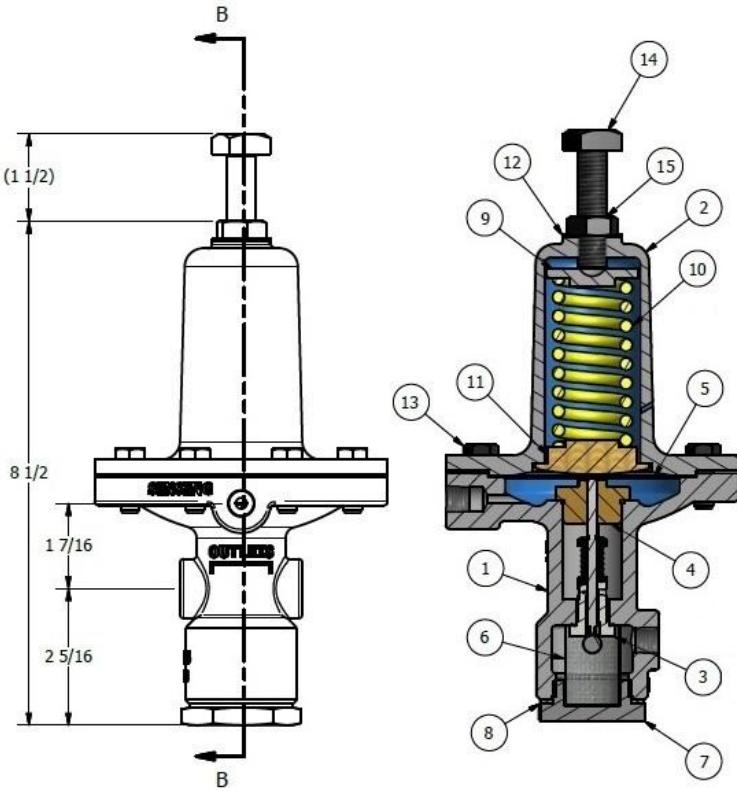

LIST OF COMPONENTS

ITEM	QTY	DESCRIPTION	MATERIAL
1	1	TYPE D SERIES PILOT BODY	STEEL, ASTM A-216 WCB
2	1	SPRING COVER	STEEL, ASTM A-216 WCB
3	1	SEAT ASSEMBLY	STAINLESS STEEL, 420 50-55 Rc
4	1	BUSHING	BRASS, ASTM B-16
5	2	DIAPHRAGM (LONG LASTING)	PHOSPHOR BRONZE, ASTM B-103
6	1	SCREEN (60 MESH)	STAINLESS STEEL, 304
7	1	BOTTOM PLUG	STAINLESS CF8M, ASTM A-351
8	1	BOTTOM PLUG GASKET	COPPER / STAINLESS STEEL, 302
9	1	TOP SPRING BUTTON	STAINLESS STEEL, 300 SERIES
10	1	SPRING	SAR 1060, OIL TEMPERED STEEL
11	1	BOTTOM SPRING BUTTON	BRASS
12	1	RANGE ID TAG	ALUMINUM
13	8	5/16-18 UNC - 0.875 Cap Screw	STEEL
14	1	1/2 - 13 SQUARE BOLT	STEEL
15	1	1/2 - 13 Hex Nuts Hex Jam Nut	STEEL



Note: Shown with optional blowdown

PRESSURE ADJUSTING SPRING RANGES

Pilot Pressure Range	Identifying Colors
3-25 psig	yellow
20-100 psig	blue
80-200 psig	red

Note: This pilot includes a 60 mesh screen (7) for protection of the head and seat. Periodic inspection/cleaning is recommended. Optional blowdown is also available.

Each Watson McDaniel Company Product is warranted against defects in material and workmanship for one year from date of shipment. This warranty extends to the first retail purchaser only. All defective material must be returned to the person from whom you purchased the Product, transportation prepaid, free of any liens or encumbrances, and if found to be defective will be repaired free of charge or replaced, at the warrantor's or seller's option. If the material is replaced, any replacement will be invoiced in the usual manner and after inspection of alleged defective material an adjustment will be made for depreciation caused by purchaser's use. In no event will Watson McDaniel Company be liable to do more than refund the original contract price. Incidental and consequential damages are excluded, whether under this warranty or otherwise. All implied warranties, including warranties of merchantability and fitness for a particular purpose, are disclaimed and excluded.

INSTALLATION

This Pressure Reducing Pilot is a direct dimensional replacement of the SP Type D Series and should be installed identically. A Fitting Kit consisting of (1) union and (1) male branch tee is included (tubing not included). Consult SP Type D Series Pilot Installation Instructions if additional reference is required.

START-UP AND SETTING DOWNSTREAM PRESSURE

1. Follow normal procedure for proper start-up of main valve. Consult relevant technical documentation if additional reference is required.
2. To set downstream pressure, slowly turn pilot adjusting screw slowly clockwise until valve opens and passes steam. Adjust pilot spring until desired downstream pressure is obtained. A time period may be involved to fill the downstream pipe system with steam before adjusting spring can be adjusted for correct pressure setting.
3. After system has stabilized readjust spring setting to obtain exact desired pressure and tighten adjusting screw locknut.

SERVICING INSTRUCTIONS: PRESSURE PILOT

- 1.) Servicing pilot valve diaphragm. (6)
 - a) Remove all compression from spring by loosening pilot adjusting screw – turn counter-clockwise. (15)
 - b) Close inlet isolation valve. Ensure downstream pressure is zero.
 - c) Remove pilot cover cap screws (14) and cover (2).
 - d) Inspect the metal diaphragms (6) for cracks and/or wrinkles. Replace diaphragms if necessary.
 - e) Clean dirt from inside pilot assembly and diaphragm surfaces. Recommend a bead of Teflon pipe sealant be applied to pilot body (1) diaphragm cavity.
 - f) Reassemble as required making sure bolting is taken-up evenly.
- 2.) Servicing pilot head and seat assembly.
 - a) Shut down system as required. Disconnect sensing line from pilot.
 - b) Remove all compression from spring by loosening pilot adjusting screw – turn counter-clockwise. (15)
 - c) Consider disassembling pilot from main valve or simply remove bottom cap (8) for access to head and seat assembly cartridge. Clean screen, if required.
 - d) Carefully remove the pilot head and seat (3) which is one complete cartridge assembly, using a socket wrench.
 - e) Inspect – if any wear or damage is noted, replace complete assembly.
 - f) Before reinstalling pilot head and seat assembly, consider inspecting guide bushing (5) for possible binding of pilot stem and excessive clearance between guide and stem. Replace only if necessary. Follow instructions above for removal of the spring case and diaphragms for access to the guide bushing.
 - g) Reassemble as required, including all gaskets. Make sure that head and seat assembly is only tightened snugly – DO NOT OVERTIGHTEN!