

HD Series Pilot Operated Regulating Valve - PP & PP5 Spring-loaded Pilot

Installation

Operations &

Maintenance

Manual

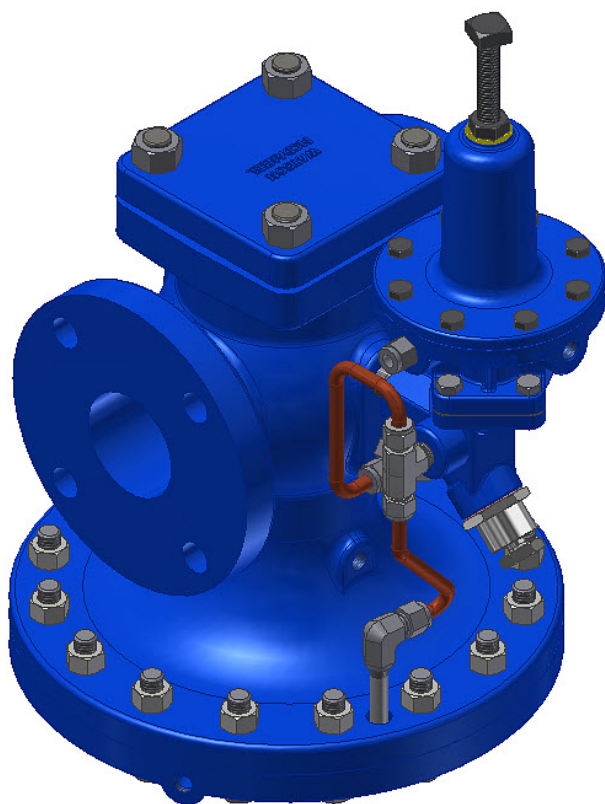

428 Jones Boulevard
Limerick Airport Business Center
Pottstown, PA 19464

Phone: (610)495-5131
Fax: (610)495-5134
www.watsonmcdaniel.com

HD Specifications

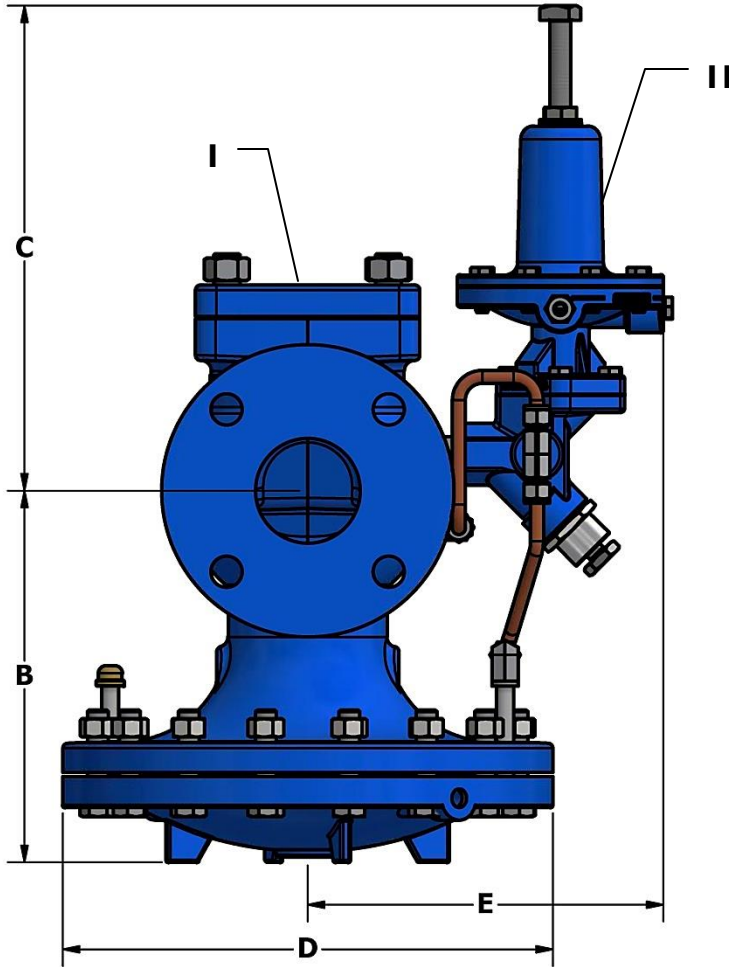

Item	Description
I	Main Valve Assembly
II	Pilot Assembly

HD Valve Pressure-Temperature Ratings

PMO Max. Operating Pressure	300 PSIG
NPT	450 PSIG @ 650°F
150# FLG	150 PSIG @ 566°F
300# FLG	450 PSIG @ 650°F

Pressure Adjusting Range for Pilot Spring

Pressure	Color
5-25 PSIG	Yellow
20-100 PSIG	Blue
80-200 PSIG	Red

Note: Y, B, R is indicated on the pilot at the adjustment screw to provide the pressure reducing spring range.

Figure 1: HD Pressure Regulating Valve

Size	(A) Face to Face			B	C	D	E	F	Weight (lbs)		
	NPT	150#	300#						NPT	150#	300#
1/2"	4 3/8			5 1/2	3 3/8	6 1/2	7 3/4	0.143	18		
3/4"	4 3/8			5 1/2	3 3/8	6 1/2	7 3/4	0.143	18		
1"	5 3/8	5 1/2	6	6 1/4	3 1/2	7	7 3/4	0.149	23	40	45
1 1/4"	6 1/2			7 3/8	4 7/8	8 3/4	8 1/4	0.175	43		
1 1/2"	7 1/4	6 7/8	7 3/8	7 3/8	4 7/8	8 3/4	8 1/4	0.175	43	55	60
2"	7 1/2	8 1/2	9	8 1/4	5 3/8	10 7/8	8 1/2	0.202	65	75	85
2 1/2"		9 3/8	10	9	5 3/4	11 3/4	8 1/2	0.209		100	105
3"		10	10 3/4	8 7/8	6 3/4	13 1/4	9 1/2	0.237		130	145
4"		11 7/8	12 1/2	10 7/8	7 1/2	14 3/4	10 1/2	0.237		215	235
6"		15 1/8	16	14 1/8	10	19 3/4	11 3/4	0.326		420	470

All dimensions are in inches unless noted differently

For PP5 Pilot: For sizes 1/2" to 1 1/2" add 2 1/2" to "C" dimension

For sized 2" to 6" add 5" to "C" dimension

Add 1 1/2" to "E" dimension for all sizes

Each Watson McDaniel Company Product is warranted against defects in material and workmanship for one year from date of shipment. This warranty extends to the first retail purchaser only. All defective material must be returned to the person from whom you purchased the Product, transportation prepaid, free of any liens or encumbrances, and if found to be defective will be repaired free of charge or replaced, at the warrantor's or seller's option. If the material is replaced, any replacement will be invoiced in the usual manner and after inspection of alleged defective material an adjustment will be made for depreciation caused by purchaser's use. In no event will Watson McDaniel Company be liable to do more than refund the original contract price. Incidental and consequential damages are excluded, whether under this warranty or otherwise. All implied warranties, including warranties of merchantability and fitness for a particular purpose, are disclaimed and excluded.

Principle of Operation

The HD Pilot Operated Pressure Regulating Valve is designed to maintain a consistent downstream pressure for steam applications.

1. High pressure steam enters the valve and fills the chamber above the seat in the main body.
2. The high pressure steam moves to the pilot base where a stainless steel screen captures unwanted dirt and particles. This allows cleaner steam to pass through to the pilot base.
3. Turning the pilot screw clockwise applies pressure to the pilot diaphragm which opens the pilot valve.
4. The steam then travels through the pilot valve to the lower pilot chamber which flows to the external transmission tubing. This then fills the area under the main valve diaphragm.
5. The pressure then lifts the main valve disc which allows the upstream steam to flow to the downstream piping.
6. The pilot control piping, which is recommended to be a minimum of 10 pipe diameters downstream from the valve, also fills with steam. The steam then builds pressure under the pilot diaphragm which forces the diaphragm against the spring while throttling to maintain a constant pressure.

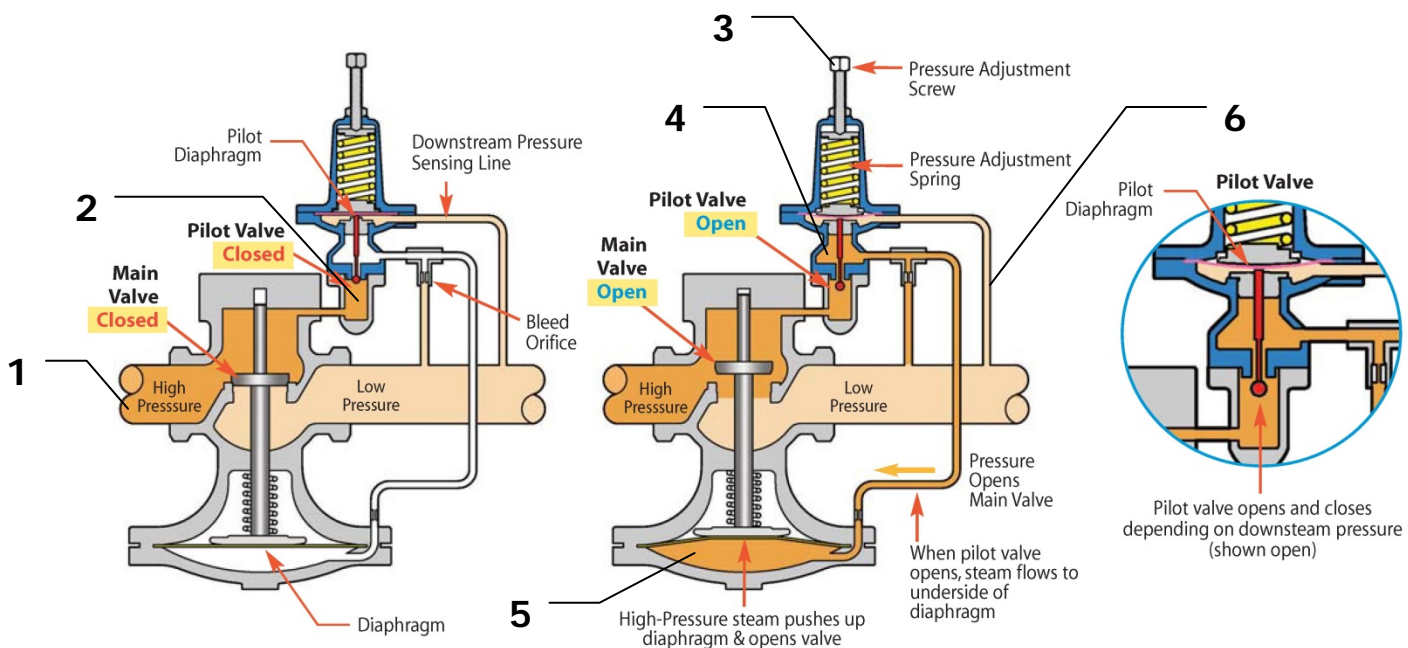

Figure 2: HD Valve Operation Illustration

Installation

1. Make sure steam supply is safely shut off. Fig. 3 piping hookup is a typical installation to be used as a guide for planning piping.
2. Valve should be installed in horizontal position with flow in direction as indicated by arrow on body. Main valve diaphragm to be in down position. **Caution:** When installing flanged valves make sure flange bolts are tightened evenly so as not to overstress and crack flanges.
3. Piping will need to be adequately sized to handle the flow capacity, velocity, and pressure.
4. Piping upstream should generally be 1-2 times larger than valve size and downstream side of valve is generally 2-3 times larger than valve to eliminate flow restriction.
5. An eccentric reducer at inlets will reduce the risk of water hammer by removing a potential condensate collection point.
6. Install a steam trap in a drip leg ahead of the pressure reducing valve to remove the condensate, insure proper operation, and increase valve life.
7. A 'Y' type strainer should be installed in the horizontal position before the pressure reducing valve to prevent any collection of condensate. Make sure sufficient clearance is allowed so strainer screen can be removed.
8. By-pass connections of same size as pressure reducing valve is recommended. (See Fig. 3) Use gate valves before and after pressure reducing valve and globe valve as by-pass valve.

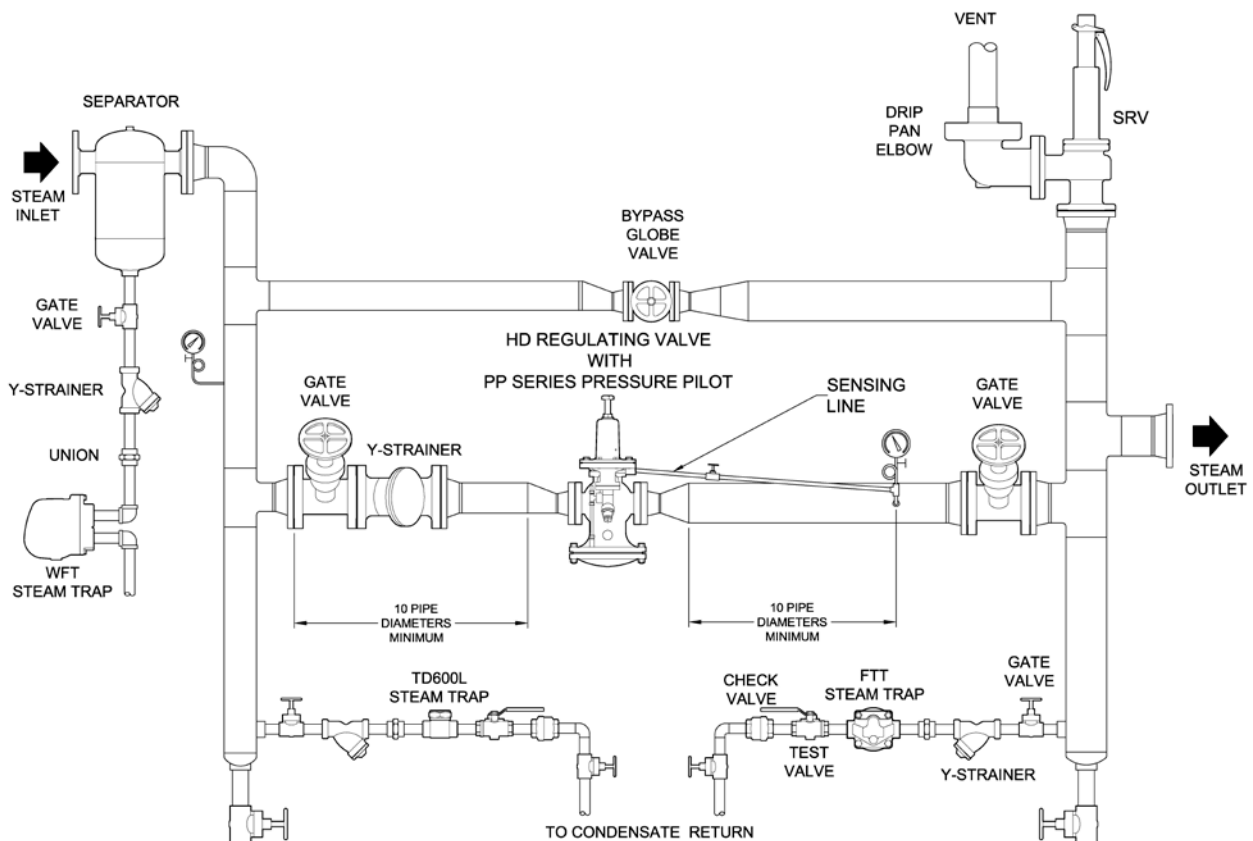

Figure 3: Recommended Single Stage PRV Station Installation

Installation continued

9. Assemble Pilot to Main Valve:
 - a) Remove pilot adaptor protector from main valve.
 - b) Place gasket on pilot adaptor making sure roll pin in pilot adaptor is inserted thru small hole in gasket.
 - c) Assemble pilot to adaptor making sure roll pin in adaptor is inserted in blind hole assembly in the pilot. Tighten bolts evenly.
10. Pilot line connections.
 - a) Pilot sensing line should be either 1/4" pipe or 5/16 O.D. copper tubing.
 - b) Pilot sensing line to be connected from pilot valve to the downstream piping, ten pipe diameters from pressure reducing valve and in an area where there will be a minimum amount of turbulence. (If pilot is moved to opposite side of valve the tubing must be rearranged to connect to downstream piping.)
 - c) To keep condensate out of pilot valve the pilot line should be sloped downward away from valve.
 - d) When reduced pressure is supplied to a single piece of equipment such as a tank, heater, kettle, etc. the pilot line may be connected directly to the point where regulation is desired.
 - e) A needle valve should be installed in the pilot line so valve can be isolated for service.
 - f) A pressure gage should be installed in the pilot line connection in the downstream piping. (Use condensate loop & gage valve.)

Start up

1. Make sure all lines have been blown down to remove initial dirt and scale from system.
2. Close all valves in installation.
3. Loosen locknut on pilot adjusting screw, and then loosen adjusting screw enough to release all tension on adjusting spring.
4. Open valve ahead of steam trap or other drain valve to make sure all condensate is drained from inlet piping. If this is not done, serious damage to the piping system can occur as a result of water hammer.
5. After all condensate is removed, open isolation valve in pilot sensing line.
6. Open downstream gate valve. Bypass, if installed, should be closed.
7. Verify that the bypass valve is closed. Open inlet gate valve slowly. Watch for possible water hammer.
8. Turn pilot adjusting screw slowly clockwise until valve opens and passes steam. Adjust pilot spring until desired downstream pressure is obtained. A time period may be involved to fill the downstream pipe system with steam before adjusting spring can be adjusted for correct pressure setting.
9. After system has stabilized readjust spring setting to obtain exact desired pressure and tighten adjusting screw locknut.
10. Inspect all piping connections and valve for possible leaks and tighten as required. Check and retighten main valve diaphragm bolts.
11. Parallel Reducing Station Notes:
 - a) When one of the pressure regulators needs service, be sure to isolate it from the outlet pressure of the other unit and bleed off all back pressure before disconnecting any of the pilot tubing. Failure to do this may result in the rupture of the main valve diaphragm.
 - b) To establish automatic control between the two regulators the pilot settings must be a minimum of two psig apart. The unit with the higher setting will carry the low load conditions of service and at maximum load both valves will be on line.

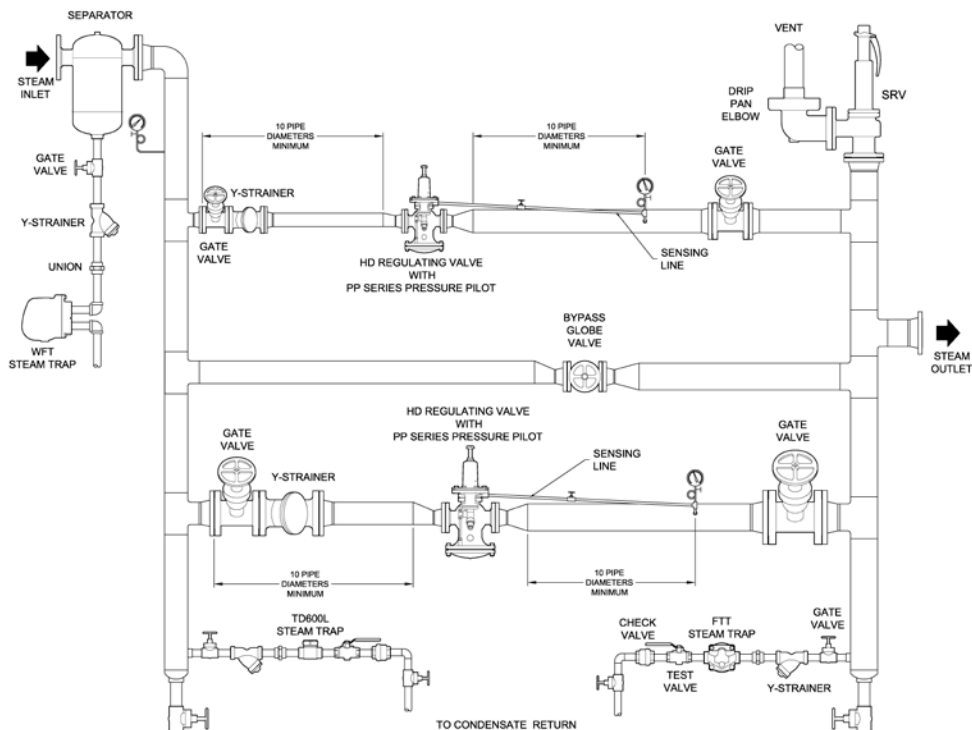

Figure 4: Recommended Parallel PRV Station Installation

Maintenance

Main Valve Assembly		
Item	Description	Material
18	Pilot Adapter	Ductile Iron
19	Blowdown Valve	Stainless Steel
20	Screen, 40 Mesh	Stainless Steel
21	Nipple	Black Pipe, Sch, 80
22	Male Branch Tee	Brass
23	Tubing, Pilot to Body	Copper Tubing
24	Elbow, Tube to Pipe	Brass
25	Tubing, Pilot to Diaphragm	Copper Tubing
26	Main Valve Body	Ductile Iron
27	Spring	302 Stainless Steel
28	Gasket, Diaphragm Cover	Grafoil
29	Orifice Ass'y, Diaphragm	Brass (Stn. Stl. Wire)
30	Diaphragm, Main Valve	Phosphor Bronze
31	Diaphragm Cover	Ductile Iron
32	Set Screw	Stainless Steel
33	Name Plate	Stainless Steel
34	Diaphragm Plate	C.I. A126 Cl. B
35	Cap Screws	Steel
36	Nuts	Steel
37	Plug Stop	Steel Tubing
38	Stem Guide Ass'y	Brass
39	Seat Ring	402 S.S.
40	Disc & Stem Ass'y	Stainless Steel
41	Gasket, Cover	Grafoil
42	Cover Assembly	Ductile Iron
43	Nuts	Steel
44	Bleed Orifice, Male Branch Tee	Brass

Pilot Assembly		
Item	Description	Material
1	Adjusting Screw	Steel
2	Pressure Range Washer	Aluminum
3	Lock Nut	Steel
4	Spring Cap	C.R.S. B-1117
5	Pilot Cover	Ductile Iron
6	Upper Spring Plate	H.R.S.
7	Spring	Oil Temp. Steel
8	Lower Spring Plate Ass'y	H.R.S.
9	Cap Screws	Steel
10	Diaphragms (2)	Phosphor Bronze
11	Body, Pilot	Ductile Iron
13	Packing House Bushing	Brass B-16
14	Head & Seat Ass'y	Stainless Steel
15	Cap Screws	Steel
16	Seat Gasket	302 S.S.
17	Gasket	Non-Asbestos

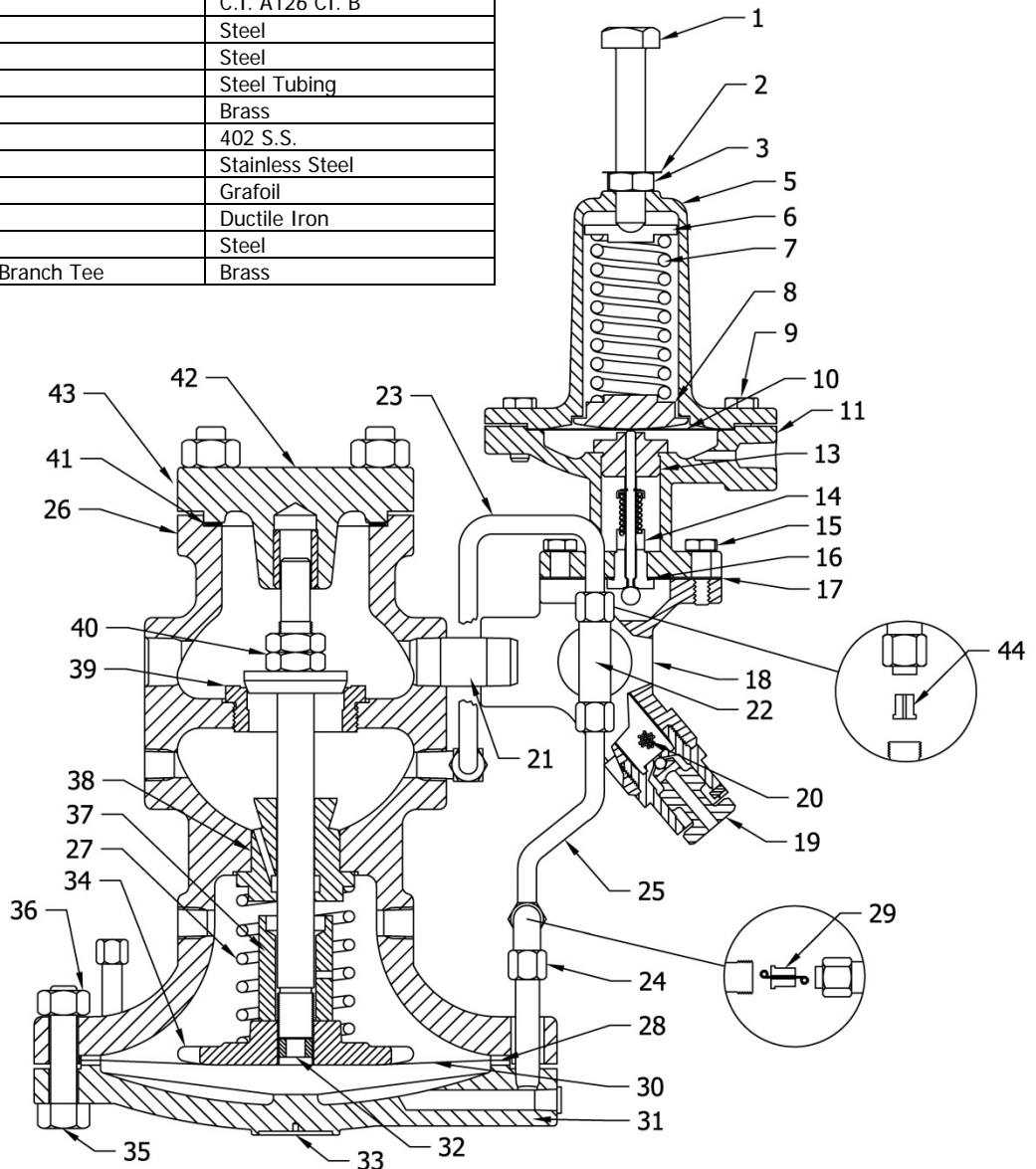

Figure 5: HD Regulating Valve Assembly

Proper maintenance is significant for reliable operation of the valve. Frequency of cleaning and maintenance performed are dependent on the conditions of the steam system.

A. General Service Inspection

1. Inspect all connections for leaks and tighten as required.
2. Inspect and clean pilot screen.
3. Inspect and clean bleed and diaphragm orifice.
4. Blow down or clean the pilot and all pipe line strainers in the system.
5. Verify the pressure is properly set after blow down and readjust if necessary.

Note: At a minimum, these maintenance operations should be performed a few days after the valve has been initially installed and shortly after the start up during each heating season.

Orifices

There are 2 different orifices located on the Valve. The Tee Bleed orifice is located on the Pilot and supplies a pressure relief path back to the main valve body. The end of the Tee with the orifice, which has an indicator mark, should be installed with the orifice side up as shown in Figure 6. The Elbow Diaphragm orifice is located outside the main valve body opposite of the diaphragm cover.

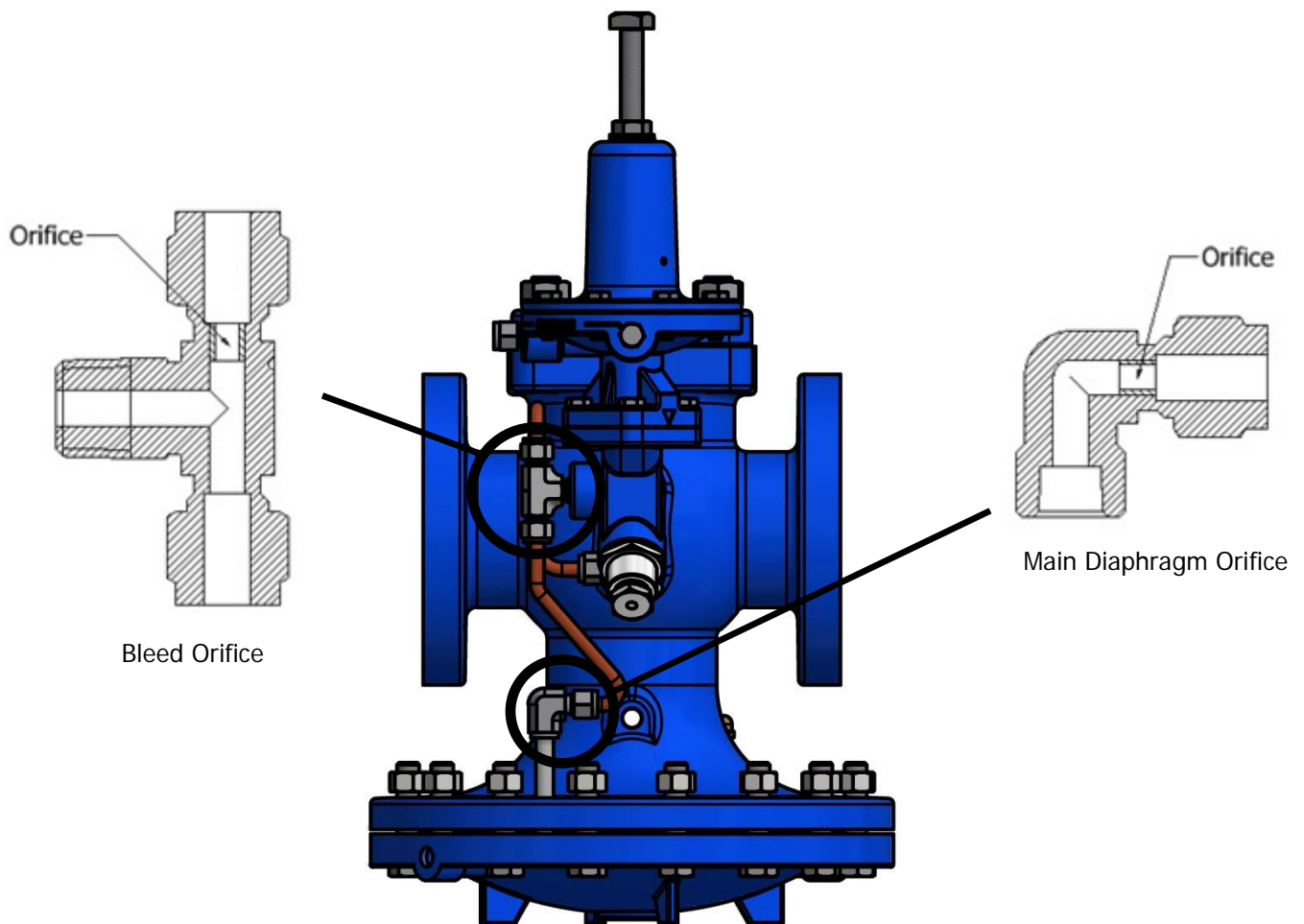

Figure 6: HD Main Valve Orifice Locations

B. Pressure Pilot Servicing

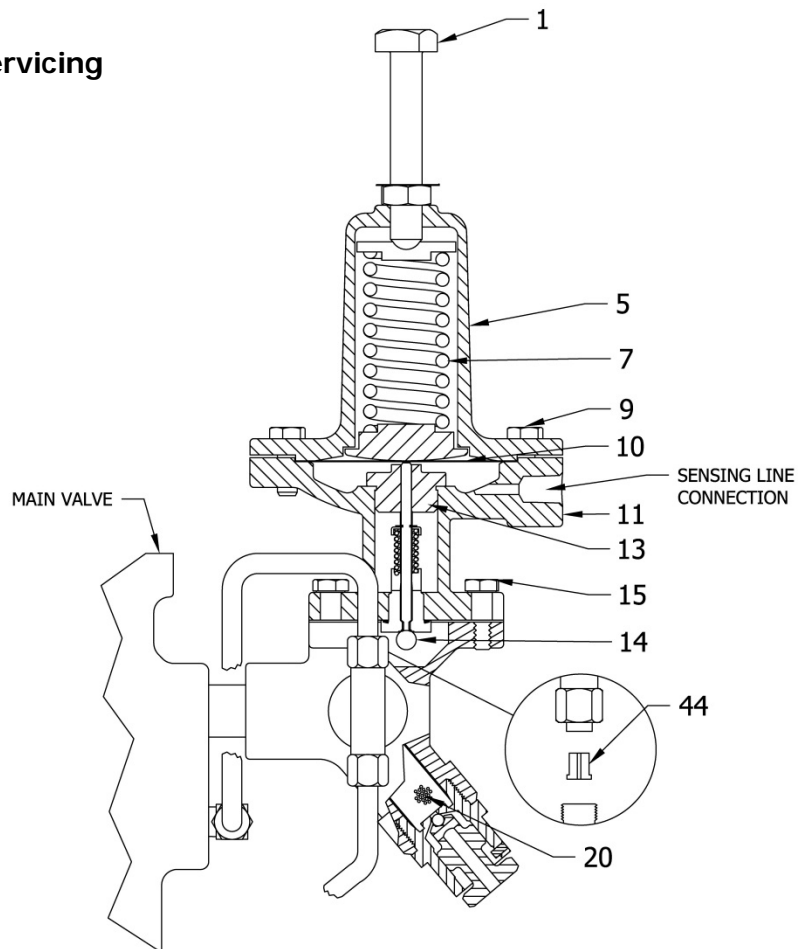

Figure 7: Pressure Pilot Cross Section

Pressure Pilot Servicing

CAUTION – Pilot must be cool before disassembly

1. Servicing pilot valve diaphragm. (10)
 - a. Loosen tension on pilot adjusting screw. (1)
 - b. Shut off inlet gate valve. Downstream pressure should be zero.
 - c. Remove pilot cover cap screws (9) and cover (5).
 - d. Inspect the metal diaphragms (10) for cracks and wrinkles. Replace diaphragms if necessary.
 - e. Clean dirt from inside pilot assembly and diaphragm surfaces. Recommend a bead of Teflon pipe sealant be applied to pilot body (11) diaphragm cavity.
 - f. Reassemble as required making sure bolting is taken-up evenly.
 - g. Suggest pilot adaptor screen (20) be checked at this time.

2. Servicing pilot seat and disc assembly.
 - a. Shut down system as required. Disconnect sensing line from pilot.
 - b. Loosen tension on pilot adjusting spring. (7)
 - c. Remove pilot assembly from pilot adapter by removing cap screws. (15)
 - d. Screw out the pilot head and seat (14) which is one complete cartridge assembly.
 - e. Inspect, if any wear or damage is noted, replace complete assembly.
 - f. Before reinstalling pilot head and seat assembly, inspect packing house bushing (13) for possible binding of pilot stem and excessive clearance between guide and stem. Replace only if necessary.
 - g. Reassemble as required. Inspect male branch tee orifice. (44)

C. Main Valve Servicing

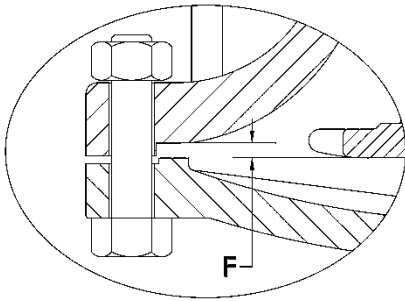

See page 11 for further detail.

Figure 8: HD Main Valve Cross Section

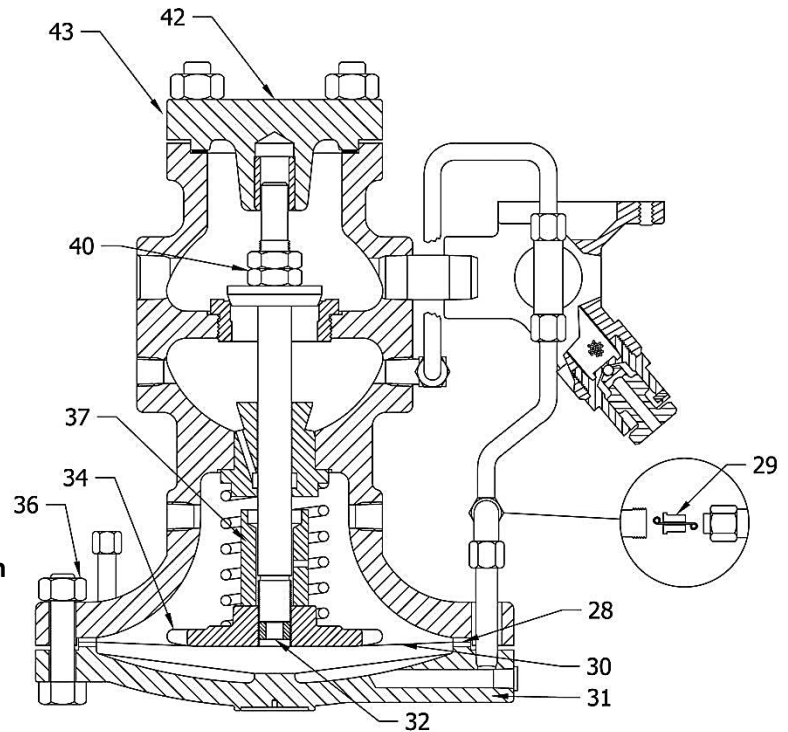

CAUTION:
Regulator must be cool before disassembly

1. Servicing main valve diaphragms (30).
 - a. Shut off inlet gate valve and make sure downstream pressure is zero. Downstream gate valve could also be shut when pressure is at zero to prevent any downstream condensate from entering the valve.
 - b. Disconnect copper tubing to diaphragm chamber at 'A' check diaphragm orifice (29) for damage, etc. **CAUTION:** Some hot condensate may leak from line and diaphragm chamber.
 - c. Loosen main valve diaphragm nuts (36). **CAUTION:** Chamber filled with condensate which could be hot. First slightly loosen nuts, and then further loosen several nuts on opposite side from where you are standing. Pry cover from valve allowing condensate to drain from valve away from you. Gently pry diaphragm loose from body to drain condensate from body of valve.
 - d. Remove all bolts and diaphragm cover (31).
 - e. Inspect the two (2) metal diaphragms (30) for small cracks and wrinkles. Replace if necessary.
 - f. Clean diaphragm, diaphragm plate and gasket surfaces before reassembly
 - g. Make sure diaphragm plate (34) is securely fastened to stem with locking set screw. Check diaphragm plate setting. See dimension 'F' above. For further help on how to set the 'F' dimension, see page 11.
 - h. Valve stem assembly (40) can be checked for proper movement by pushing up on diaphragm plate. **CAUTION:** Condensate may be in upper portion of body.
 - i. Replace diaphragm gaskets (28) if necessary. Use only factory replacement gaskets.
 - j. Center diaphragms and gaskets on cover. Bolts will assist in centering.
 - k. Assemble making sure bolts are taken-up evenly. After system is started check bolts again for tightness.
2. Servicing main valve disc and seat.
 - a. Follow disassembly instructions as noted in diaphragm servicing instructions, a) above.
 - b. Loosen diaphragm plate set screw (32) and remove diaphragm plate (34).
 - c. Remove cover nuts (43) and cover (42).
 - d. Remove stem and disc assembly from valve and inspect disc and seat for wear. Minor wear can be corrected by lapping disc and seat together with 400 grit lapping compound. Inspect the disc and seat for signs of scale or dirt which could have caused leakage.
 - e. Check for body erosion around seat ring. Check seat ring for possible damage or excessive wear and any signs of scale or dirt which could have caused leakage. Replace if necessary. Replacement seats and discs should be lapped.
 - f. Reassemble as required. Make sure plug stop (37) is installed properly.

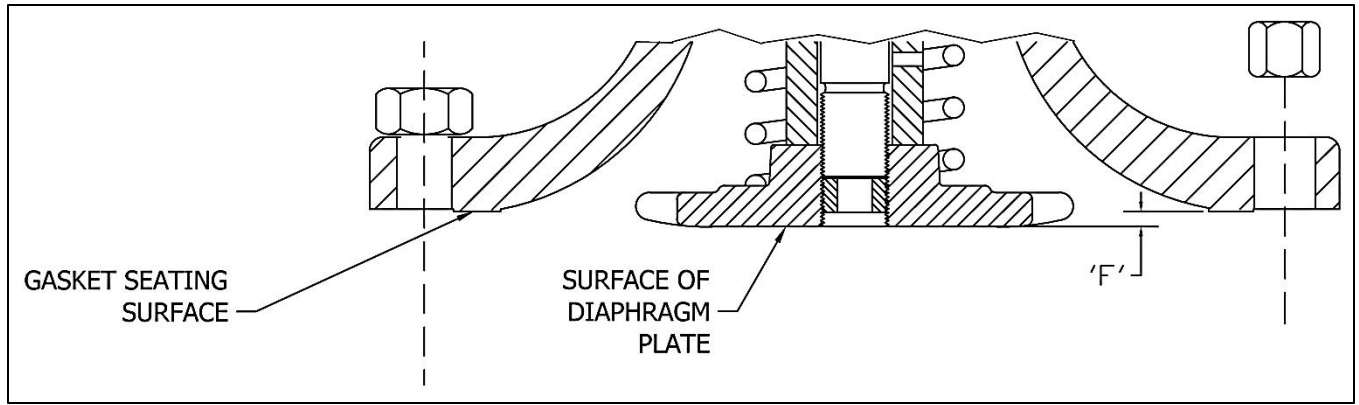

For valve sizes 1/2" through 1 1/2", gasket surface will be recessed.

'F' dimension taken from gasket surface to **center** of surface on the diaphragm plate.

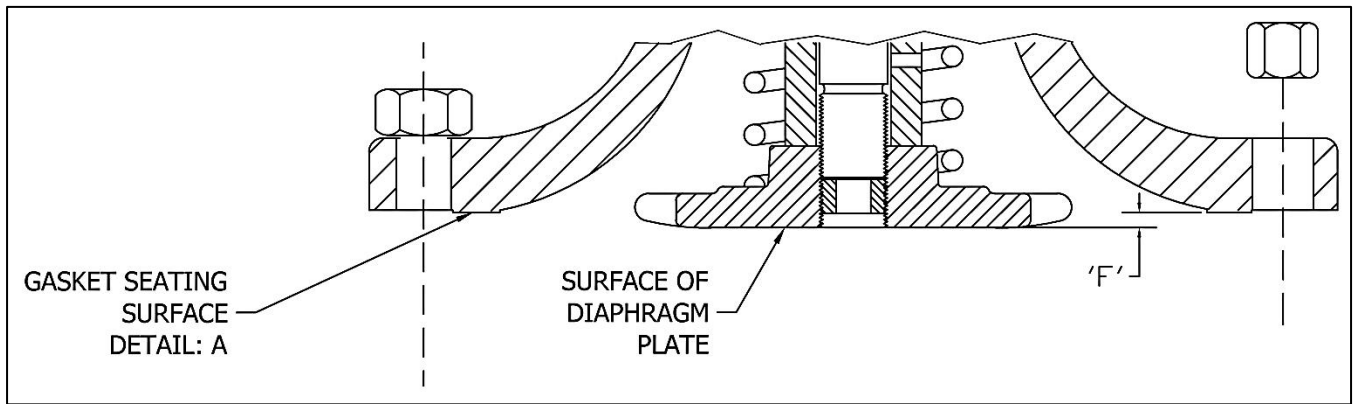

For valve sizes 2" through 6", gasket surface will be raised.

'F' dimension taken from gasket surface to **center** of surface on the diaphragm plate.

HD Valve Size	'F' Dimension
1/2"	0.143"
3/4"	0.143"
1"	0.149"
1 1/4"	0.175"
1 1/2"	0.175"
2"	0.202"
2 1/2"	0.209"
3"	0.237"
4"	0.237"
6"	0.326"

Valve Troubleshooting

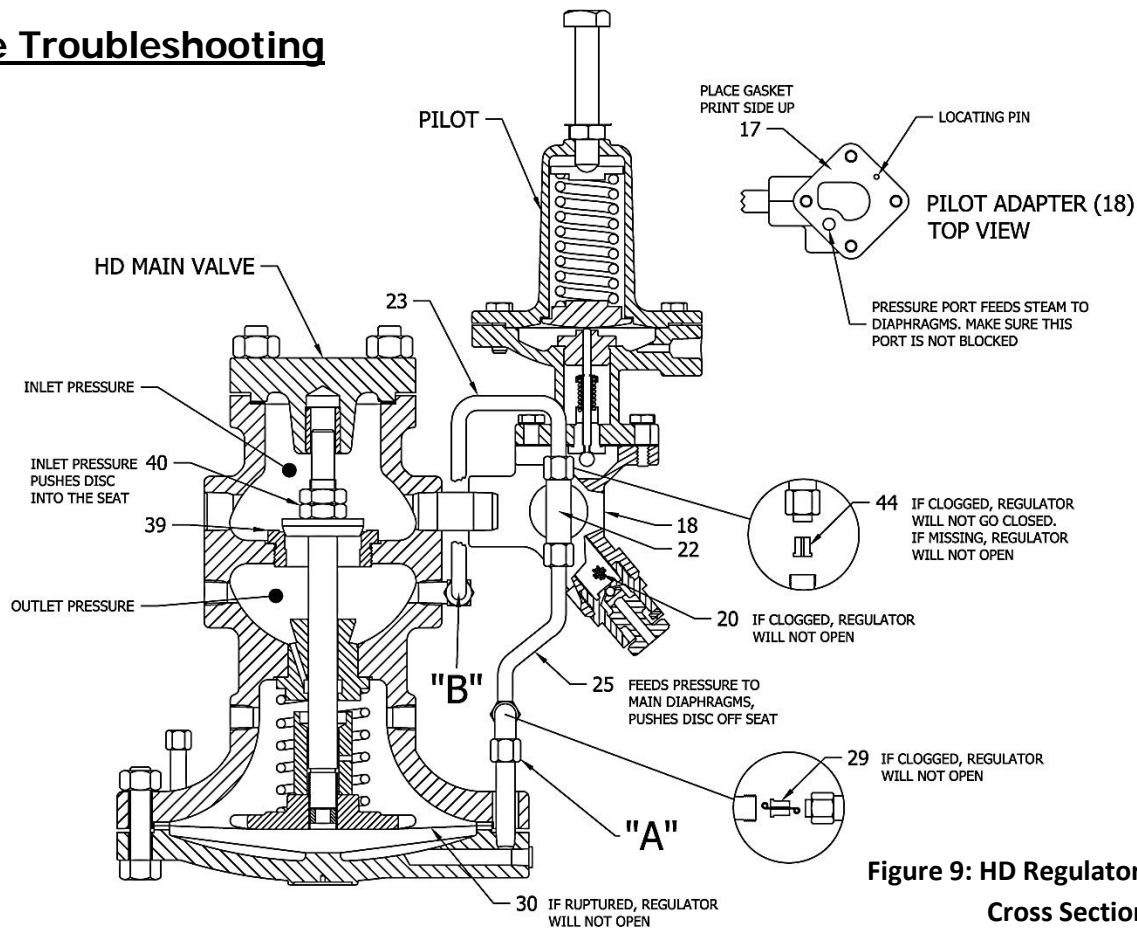

REGULATOR WILL NOT COME UP TO PRESSURE OR TEMPERATURE

1. Shut off inlet gate valve to regulator and make sure downstream pressure is zero.
2. Make sure that the Pilot Gasket (17) is properly oriented on the Pilot Adapter (18); otherwise, the pressure port in the adaptor will be blocked and regulator will not open.
3. Check Pilot Strainer (20) for blockage as well as the upstream pipeline strainer.
4. Inspect Diaphragm Orifice (29) for blockage and Diaphragms (30) for rupture.
5. Check that the Bleed Orifice (44) at the Male Branch Tee (22) is not missing.

PRESSURE OVERRIDES SET POINT: ISOLATE REGULATOR FROM PILOT FOR TESTING

1. Before isolating regulator, open up blowdown valve (19) to discharge any dirt/debris from pilot. CAUTION: Live steam and condensate present. Stand away from blowdown valve when opening. Once blown down, recheck system operation, as this may have resolved any issue with overshooting.
2. Shut off inlet block valve to regulator and make sure downstream pressure is zero.
3. Adjust the pilot to the closed position. If it is a Pressure pilot, back out the adjustment screw until there is no compression on the spring. If Temperature pilot, turn the temperature adjusting knob to the lowest setting.
4. Disconnect the pilot tube (25) at the regulator diaphragm which is indicated as point "A" in the illustration above. Also disconnect the smaller pilot tube (23) at the side of the regulator body designated point "B" in the above illustration.
5. Stand clear of the tube connections and open the block valve upstream of the Main Valve only partially to limit the steam pressure to the regulator. Full line pressure is not necessary for this test.
6. Regulator seat test - With the long pilot tube disconnected at point 'A' the regulator should be closed. If there is steam blowing out of the body side connection at point "B", the main valve and seat are leaking and require inspection for debris that is holding the valve off the seat or erosion of the sealing surfaces.
7. Pilot seat test - With the pilot closed there should not be any steam coming out of the long tubing at point "A". If there is steam flow, the pilot is not closing off and must be inspected for debris or seat erosion. Try running the adjustment screw in & out a few times to clear the debris. If that is not successful, the pilot must be cleaned, repaired or replaced.

System Troubleshooting

PROBLEM	POSSIBLE	CAUSE CORRECTION
1. Cannot set valve to give high enough downstream pressure	a) Pilot valve spring not adjusted properly	a) Readjust desired reduced pressure
	b) Pilot adjusting spring not correct	b) Check color code of spring against spring range in literature
	c) Inlet or outlet gate valve partially closed	c) Open valves
	d) Upstream pipeline strainer blocked	d) Clean strainer screen
	e) Pilot screen clogged	e) Clean screen
	f) Inlet pressure too low causing reduced capacity thru valve	f) Check with gage and correct as required
	g) Diaphragm orifice blocked	g) Check and clean orifice, Do not remove clean-out wire
	h) Bleed orifice fitting missing, installed wrong or eroded	h) Inspect and check against cut-away drawing
	i) Main valve diaphragms failed	i) Replace diaphragms
	j) Valve undersized	j) Check capacity of valve against load
	k) Downstream piping undersize	k) Check velocity of steam in piping system
2. Downstream pressure over rides set pressure under load conditions	a) Bypass valve open	a) Close valve
	b) Pilot valve adjusting spring set too high	b) Readjust to desired reduced pressure
	c) Bleed orifice blocked	c) Inspect and clean
	d) Dirt in pilot seat or stem guide	d) Purge blowdown valve. Clean pilot head and seat assembly
	e) Foreign object lodged between main valve disc and seat	e) Check main valve disc and seat. Check stem guide bushing for binding
	f) Pilot diaphragms ruptured	f) Replace pilot diaphragms
	g) Main valve seat thread leaking	g) Check body in seat ring area for erosion
	h) Valve is extremely oversized	h) Check catalog for rated capacities
	i) Valve is filled with condensate	i) Remove allen head set screw plugs above and below main diaphragm chamber to drain valve
	j) Pilot adapter gasket installed incorrectly	j) Reinstall gasket ensuring <u>ALL</u> ports are properly aligned. See cut-away drawings
	3. Valve will not open	a) Adjusting spring not set
b) Upstream isolation valve closed		b) Check and open valve
c) Upstream pipeline strainer blocked		c) Clean strainer screen
d) Pilot screen blocked		d) Remove and clean
e) Pilot stem and guide bound with dirt		e) Inspect and clean
f) Bleed orifice missing or installed wrong		f) Inspect and check against cut-away drawing
g) Diaphragm orifice blocked		g) Inspect and clean. Do not remove clean out wire
h) Main valve diaphragms ruptured		h) Replace main valve diaphragms
i) Pilot adapter gasket installed incorrectly		i) Reinstall gasket ensuring <u>ALL</u> ports are properly aligned. See cut-away drawings
4. Valve will not close		a) Bypass valve open
	b) Pilot sensing line not installed	b) Install pilot sensing line
	c) Bleed orifice blocked	c) Inspect and clean
	d) Dirt in pilot seat or guide	d) Inspect and clean
	e) Pilot diaphragms ruptured	e) Replace pilot diaphragms
	f) Foreign object lodged between main valve disc and seat	f) Inspect, clean and repair
	g) Valve is filled with condensate	g) Remove allen head set screw plugs above and below main diaphragm chamber to drain valve
	h) Pilot adapter gasket installed incorrectly	h) Reinstall gasket ensuring <u>ALL</u> ports are properly aligned. See cut-away drawings

HD Series Valve Capacities

Full Port Regulating Valve - Capacities

FULL PORT CAPACITIES - (Steam lbs/hr)														
Inlet Pressure (PSIG)	Outlet Pressure (PSIG)	1"	1-1/2"	2"	3"	4"	Inlet Pressure (PSIG)	Outlet Pressure (PSIG)	1"	1-1/2"	2"	3"	4"	
CV Factors		11	21	37	71	113	CV Factors		11	21	37	71	113	
5	0	250	500	800	1600	2600	90	45	1950	3700	6600	12700	20200	
	2	230	440	770	1500	2400		60	1700	3200	5700	10900	17400	
7	0	325	600	1100	2100	3600	100	50	2100	4100	7300	14000	22200	
	2	300	575	1000	2000	3100		60	2000	3800	6700	12900	20500	
	3	275	525	900	1800	2800		80	1400	2700	4800	9200	14700	
10	0	425	850	1500	2800	4600	125	60	2700	5200	9100	17500	28000	
	2	400	800	1400	2700	4300		75	2400	4600	8200	15700	25000	
	5	300	600	1000	2000	3200		100	1800	3500	6200	11900	19000	
12	0	475	900	1600	3100	4900	150	75	3100	6000	10600	20400	32400	
	4	400	800	1400	2700	4300		100	2700	5100	9000	17400	27700	
	7	375	700	1200	2400	3800		125	1900	3600	6400	12300	19600	
15	3	550	1000	1800	3500	5600	175	85	3700	7100	12500	24000	38200	
	5	500	900	1700	3200	5200		125	2900	5600	9900	18900	30100	
	8	400	800	1300	2600	4200		150	2100	4100	7300	14000	22200	
20	5	625	1200	2100	4000	6400	200	100	4200	8000	14100	27100	43100	
	10	550	1000	1800	3500	5600		125	3700	7100	12600	24100	38400	
	12	500	950	1600	3200	5100		150	3100	6000	10600	20300	32300	
25	7	775	1500	2600	5000	7900	225	120	4600	8700	15400	29500	47000	
	10	700	1300	2400	4600	7300		150	4200	8000	14100	27200	43300	
	15	600	1100	2000	3900	6200		175	3900	7400	13100	25200	40100	
30	12	800	1500	2700	5200	8300	250	130	5100	9700	17100	32900	53400	
	15	750	1400	2500	4900	7800		150	4700	9100	16000	30800	49000	
	20	650	1200	2100	4100	6500		200	3500	6700	11900	22800	36200	
40	18	1000	1900	3300	6400	10300	300	160	5920	11310	19220	38230	60840	
	25	850	1600	2800	5400	8700		175	5625	10740	18925	36320	57800	
	30	700	1400	2500	4700	7600		200	5155	9840	17340	33275	52960	
50	20	1200	2300	4100	7800	12400								
	30	1100	2000	3600	6900	11000								
	40	800	1500	2700	5200	8300								
60	30	1350	2600	4600	8900	14200								
	35	1250	2400	4300	8200	13100								
	50	850	1600	2900	5600	8900								
75	35	1650	3200	5600	10800	17200								
	50	1350	2600	4600	8900	14100								
	60	1150	2200	3900	7400	11800								

Note: For inlet pressures in shaded area, use low pressure main valve.

Reduced Port Regulating Valve - Capacities

REDUCED PORT CAPACITIES - (Steam lbs/hr)

Inlet Pressure (PSIG)	Outlet Pressure (PSIG)	1"	1-1/2"	2"	3"	4"	Inlet Pressure (PSIG)	Outlet Pressure (PSIG)	1"	1-1/2"	2"	3"	4"	
CV Factors		5.6	13.3	18.8	41.7	74	CV Factors		5.6	13.3	18.8	41.7	74	
5	0	59	140	197	438	777	90	45	916	2177	3077	6825	12112	
	2	53	128	181	401	712		60	789	1874	2648	5874	10425	
7	0	82	195	276	613	1088	100	50	1018	2419	3419	7584	13458	
	2	79	187	265	587	1042		60	940	2234	3158	7006	12432	
	3	74	177	250	554	983		80	706	1676	2367	5254	9324	
10	0	117	279	395	876	1554	125	60	1290	3063	4329	9603	17041	
	2	115	274	387	858	1523		75	1176	2793	3948	8757	15540	
	5	102	242	342	758	1346		100	882	2095	2961	6568	11655	
12	0	141	335	473	1051	1865	150	75	1527	3628	5128	11376	20187	
	4	133	316	446	990	1758		100	1315	3123	4414	9791	17374	
	7	115	272	385	854	1515		125	975	2316	3274	7261	12885	
15	3	173	410	580	1287	2284	175	85	1800	4272	6939	13396	23771	
	5	166	395	558	1238	2198		125	1440	3421	4835	10725	19032	
	8	149	354	500	1111	1972		150	1060	2518	3558	7893	14008	
20	5	227	541	764	1696	3009	200	100	2037	4838	6838	15168	26916	
	10	204	483	684	1517	2692		125	1836	4360	6164	13672	24262	
	12	188	447	632	1401	2486		150	1556	3695	5223	11584	20557	
25	7	282	670	948	2102	3730	225	120	2238	5360	7514	16667	29577	
	10	269	640	905	2006	3561		150	1972	4684	6621	14686	26061	
	15	235	559	790	1751	3108		175	1663	3950	5583	12384	21976	
30	12	323	768	1085	2408	4273	250	130	2511	5964	8431	18700	33184	
	15	305	726	1025	2275	4037		150	2352	5586	7896	17514	31080	
	20	263	625	883	1958	3475		200	1764	4190	5922	13136	23310	
40	18	420	998	1410	3128	5551	300	160	3015	7160	10120	22450	39840	
	25	367	872	1232	2734	4852		175	2865	6800	9615	21330	37850	
	30	311	739	1044	2317	4111		200	2625	6235	8810	19545	34680	
50	20	539	1280	1809	4013	7121								
	30	470	1117	1579	3502	6216								
	40	353	838	1184	2627	4662								
60	30	611	1451	2051	4550	8074								
	35	573	1361	1924	4268	7573								
	50	390	926	1309	2904	5154								
75	35	780	1853	2619	5809	10308								
	50	657	1561	2207	4895	8687								
	60	529	1257	1777	3941	6993								

Note: For inlet pressures in shaded area, use low pressure main valve.