

Thermostatic Air Vent

Model	AV2000 Series
Sizes	1/2", 3/4"
Connections	NPT
Body Material	Stainless Steel
PMO Max. Operating Pressure	650 PSIG
TMO Max. Operating Temperature	Saturated Steam Temp.
PMA Max. Allowable Pressure	1032 PSIG @ 100°F
TMA Max. Allowable Temperature	750°F @ 800 PSIG



Air Vents are used for Removing Air from Steam Systems

Typical Applications

The **AV2000** air vent is used on industrial steam applications up to 650 PSIG for the removal of air and non-condensable gases from process equipment, vessels and piping. The air vent should be located at a high point in the system or vessel and can be installed in any orientation.

How It Works

The thermostatic air vent contains a welded stainless steel thermal element that expands when heated and contracts when cooled. When air and non-condensable gases are present, the valve is in the open discharge position. When steam reaches the air vent, the element expands and closes the valve off tightly.

Features

- Welded stainless steel thermal element
- Hardened stainless steel seat and valve plugs for extended service life
- Integral strainer to protect from contamination
- Steam pressures up to 650 PSIG
- Special Subcool Options Available

Sample Specification

Air vent shall have a thermal element with a seal-welded tamper-proof stainless steel construction. All internals shall be stainless steel, featuring an integral strainer and hardened seat and disc.

Installation

The air vent should be located at a high point in the system or vessel and can be installed in any orientation. An isolation valve should be installed to facilitate removal and replacement without system shut-down. Unit is seal-welded and non-repairable.

MATERIALS

Housing	Stainless Steel, ASTM A351-CF3
Thermal Element	Stainless Steel
Valve & Seat	Hardened Stainless Steel, 40 Rc
Strainer Screen .033" perf.	Stainless Steel

Size/Connection NPT	Model Code	Orifice Size	PMO PSI	Weight lbs
1/2"	AV2001-12-N	3/16"	650	1.25
1/2"	AV2003-12-N	5/16"	650	1.25
3/4"	AV2001-13-N	3/16"	650	1.25
3/4"	AV2003-13-N	5/16"	650	1.25

DIMENSIONS – inches

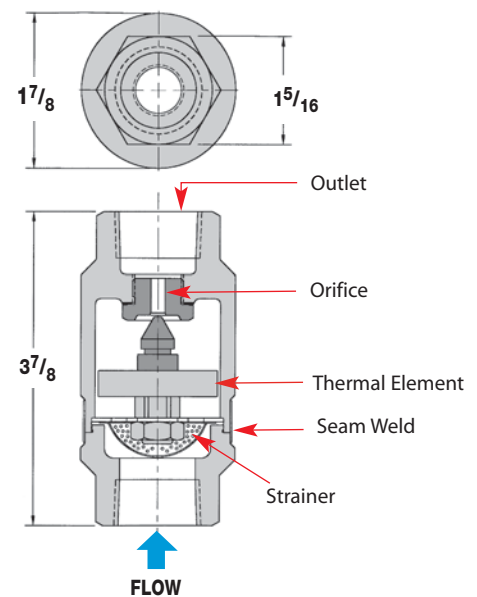

PIPELINE ACCESSORIES

CAPACITIES – Air (SCFM)

Model	Orifice Size	PMO (PSIG)	Inlet Pressure (PSIG)																	
			2	5	10	25	50	100	125	150	200	250	300	350	400	450	500	550	600	650
AV2001	3/16"	650	5.2	6.2	7.7	12.4	20.2	35.9	43.9	51.5	67.2	82.8	98.5	114	130	145	161	177	192	208
AV2003	5/16"	650	10.7	12.6	15.8	25.4	41.4	73.3	89.4	105	137	169	201	233	265	297	329	361	393	425