



APOLLO TA GREEN-LINE™ THERMOSTATIC STEAM MODULATORS

Features

- Valve and seat are made from Hardened Stainless Steel TIG welded stainless steel Tunstall Capsule® with balanced pressure stainless steel bellows
- For added protection against Thermal Shock and Water Hammer the Gemini comes equipped with a Variable Orifice Restrictor.
- Can be installed Vertically for “Freeze Proof” installation
- Functions as an efficient steam service AIR VENT as supplied, no modifications required
- Can be mounted either horizontally or vertically
- Stainless Steel Orifice Diameters can be specified to meet particular loads and pressure demands.
- Field Repairable with High Pressure Capsules available from Tunstall Inventory
- Hybrid Technology controls multiple steam and condensate demands
- Replace Inverted Bucket Traps - No priming required
- Replace Float and Thermostatic Traps
- Simple - Fast - Economical



Thermal Disc & Thermostatic Traps

PRESSURES TO 300 PSIG • TEMPERATURES TO 420°F

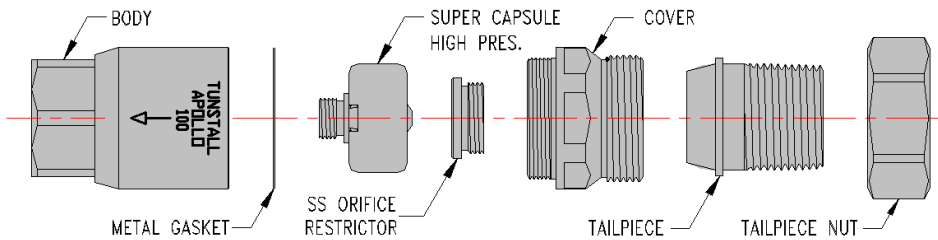

**SAVE ENERGY
TODAY!**

TYPICAL APPLICATION

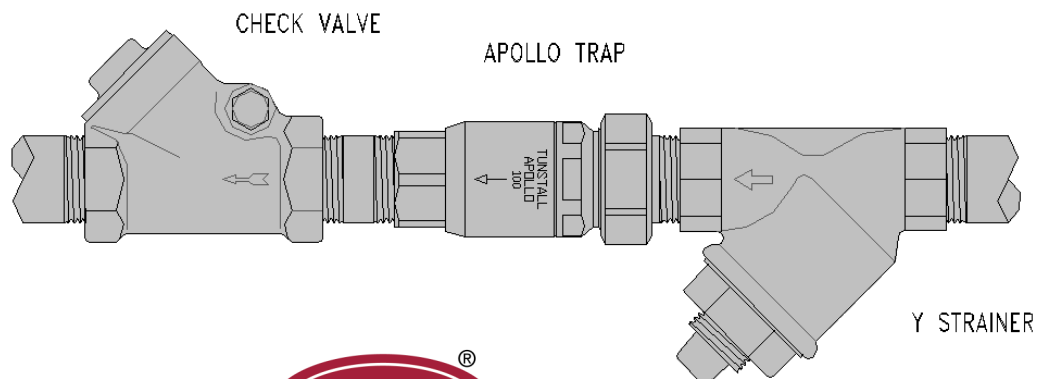

Tunstall Corporation
118 Exchange Street · Chicopee, MA 01013

Phone (413) 594-8695 · Fax (413) 598-8109
www.maconbalancing.com

© August 2017

We reserve the right to alter designs, specifications and information without notice.

Bulletin-TA-Green-Line-Apollo-1905
Thermal-Disc & Thermostatic Traps



Established 1958

APOLLO TA GREEN-LINE™ THERMOSTATIC STEAM MODULATORS

Thermal Disc &
Thermostatic Traps

APPLICATIONS

- Steam Tracing
- Sterilizers
- Drip Legs
- Cooking Equipment
- Plating Tanks
- Tire Presses
- Air Vents
- Unit Heaters
- Laundry Equipment
- Process Equipment
- Radiators
- Optional Modulating Orifice Technology

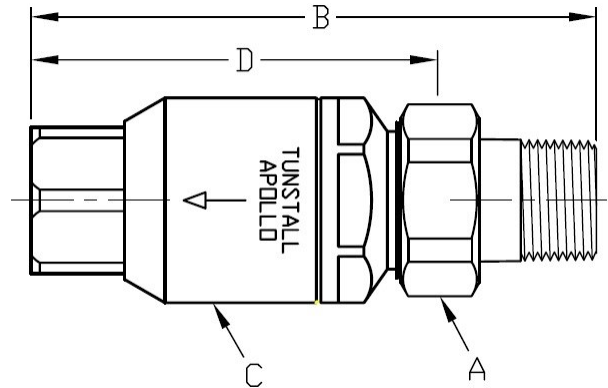

DIMENSIONS

Model No.	Pipe Size IN	Pipe Size OUT	A	B	C	D (less union)
TA-APOLLO-50	1/2 NPT M	1/2 NPT FM	1/2" Union	4-21/32"	1-3/4" Dia.	3-15/32"
TA-APOLLO-75	3/4 NPT M	3/4 NPT FM	3/4" Union	4-27/32"	1-3/4" Dia.	3-1/2"
TA-APOLLO-100	1 NPT M	1 NPT FM	1" Union	5-1/8"	1-3/4" Dia.	3-1/2"
TA-APOLLO-125	1-1/4 NPT M	1-1/4 NPT FM	1-1/4" Union	6-1/8"	2-1/4" Dia.	4-1/2"
TA-APOLLO-HC-200	2 NPT M	2 NPT FM	2" Union	6-3/4"	3" Dia.	4-3/4"

WORKING CAPACITY - PROCESS APPLICATIONS (LBS. Con / HR)

Model No.	DIFFERENTIAL PRESSURE (PSIG)											Repair Kit	
	1.0	2.0	5.0	10	15	30	70	100	125	150	200		250
TA-APOLLO-50	148	208	330	470	570	750	1240	1480	1650	1810	2090	2340	TA-APOLLO-RK-50
TA-APOLLO-75													TA-APOLLO-RK-75
TA-APOLLO-100													TA-APOLLO-RK-100
TA-APOLLO-125													TA-APOLLO-RK-125
APOLLO HIGH CAPACITY													Repair Kit
TA-APOLLO-HC-75	1320	1870	2950	4170	5110	7230	10920	12720	14040	15240	17410	19320	TA-APOLLO-RK-HC-75
TA-APOLLO-HC-100													TA-APOLLO-RK-HC-100
TA-APOLLO-HC-125													TA-APOLLO-RK-HC-125
TA-APOLLO-HC-200													TA-APOLLO-RK-HC-200