

spirax sarco

Cast Iron Float & Thermostatic Steam Traps FTI-15, FTI-30, FTI-75, FTI-125, FTI-200

The Spirax Sarco FTI contains a float valve mechanism which modulates to discharge condensate continuously at steam temperature while non-condensable gases are released by a separate internal balanced pressure thermostatic air vent. The in-line piping connections simplify installation.

Model	FTI-15	FTI-30	FTI-75	FTI-125	FTI-200
PMO	15 psig	30 psig	75 psig	125 psig	200 psig
Sizes	1/2", 3/4", 1", 1-1/2"				
Connections	NPT				
Construction	Cast Iron Body & Cover Stainless Steel Internals				
Options	Gauge Glass, Vacuum Breaker				

Typical Applications

Air heating coils, heat exchangers, steam main drip stations; small process equipment, particularly when controlled by a modulating temperature control valve; replacement of less efficient inverted bucket traps on unit heating equipment.

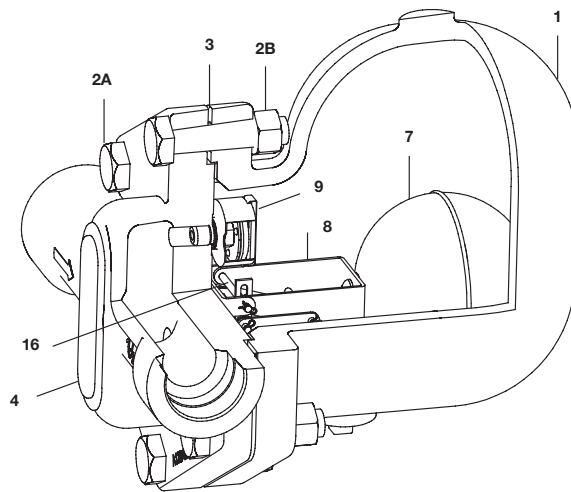
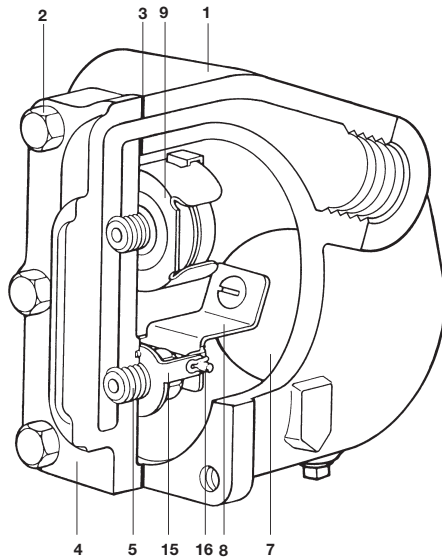

Limiting Operating Conditions

Max. Operating Pressure (PMO)	FTI-15: 15 psig (1.0 barg)
	FTI-30: 30 psig (2.1 barg)
	FTI-75: 75 psig (5.2 barg)
	FTI-125: 125 psig (8.6 barg)
FTI-200: 200 psig (13.8 barg)	

Max. Operating Temperature 450°F
all operating pressures

Pressure Shell Design Conditions

PMA 200 psig/up to 450°F 13.8 barg/up to 232°C
Max. allowable pressure

TMA 450°F/0-200 psig 232°C/0-13.8 barg
Max. allowable temperature

Construction Materials

No.	Part	Material	
1	Body	Cast Iron	ASTM A126 CL B
2	Cover Screws	Carbon Steel	ASTM A449
2A	Cover Bolts	Alloy Steel	ASTM A 193 B7
2B	Cover Nuts 3/4" & 1"	7/16 - 14 UNC-2A	ASTM A 194 2H
3	Cover Gasket	Graphite	
4	Cover	Cast Iron	ASTM A126 CL B
5	Valve Seat	Stainless Steel	
7	Ball Float	Stainless Steel	
8	Float Arm	Stainless Steel	
9	Air Vent Assembly	Stainless Steel	
	Air Vent Head	Stainless Steel	
	Air Vent Seat	Stainless Steel	
15	Seat Bracket	Stainless Steel	
16	Pivot Pins	Stainless Steel	
18	Valve Head	Stainless Steel	

Local regulation may restrict the use of this product below the conditions quoted. Limiting conditions refer to standard connections only.
In the interests of development and improvement of the product, we reserve the right to change the specification.

TI-2-321-US 2.14

Cast Iron Float & Thermostatic Steam Traps

FTI-15, FTI-30, FTI-75, FTI-125, FTI-200

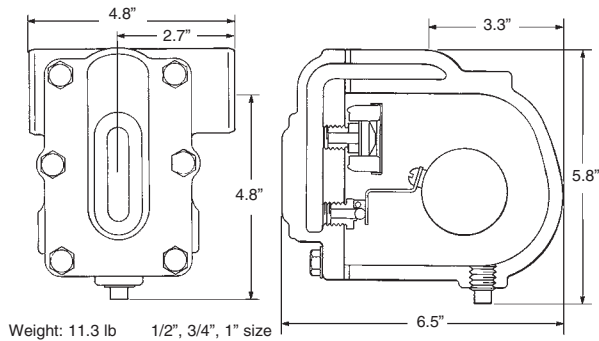

Weight: 11.3 lb
5.1 kg
1/2", 3/4", 1" size

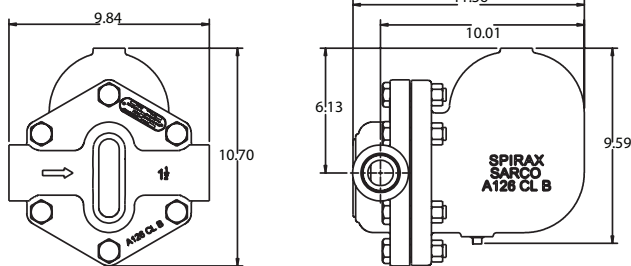

Weight: 52 lb
23.6 kg
1-1/2" size

Sample Specification

Steam traps shall be of the mechanical ball float type having cast iron bodies, NPT horizontal in-line connections, and all stainless steel internals. Incorporated into the trap body shall be a stainless steel balanced pressure thermostatic air vent capable of withstanding 450°F and resisting waterhammer without sustaining damage. Internals of the trap shall be completely serviceable without disturbing the piping.

Installation

A pipeline strainer should be installed ahead of any steam trap. Full-port isolating valves should be placed to permit servicing. The trap should be installed below the drainage point of the equipment with a collecting leg before the trap, in a position so that the float arm is in a horizontal plane and the float rises and falls vertically with the flow direction as indicated on the body. Refer to the IMI which accompanies the product for complete instructions.

Maintenance

This product can be maintained without disturbing the piping connections. Complete isolation from both supply and return line is required before any servicing is performed. The trap should be disassembled periodically for inspection and cleaning of the valve head and seat, operating mechanism and air vent. Worn or damaged parts should be replaced using a complete valve mechanism assembly and/or air vent assembly.

Complete installation and maintenance instructions are given in the IMI, which accompanies the product.

Spare Parts

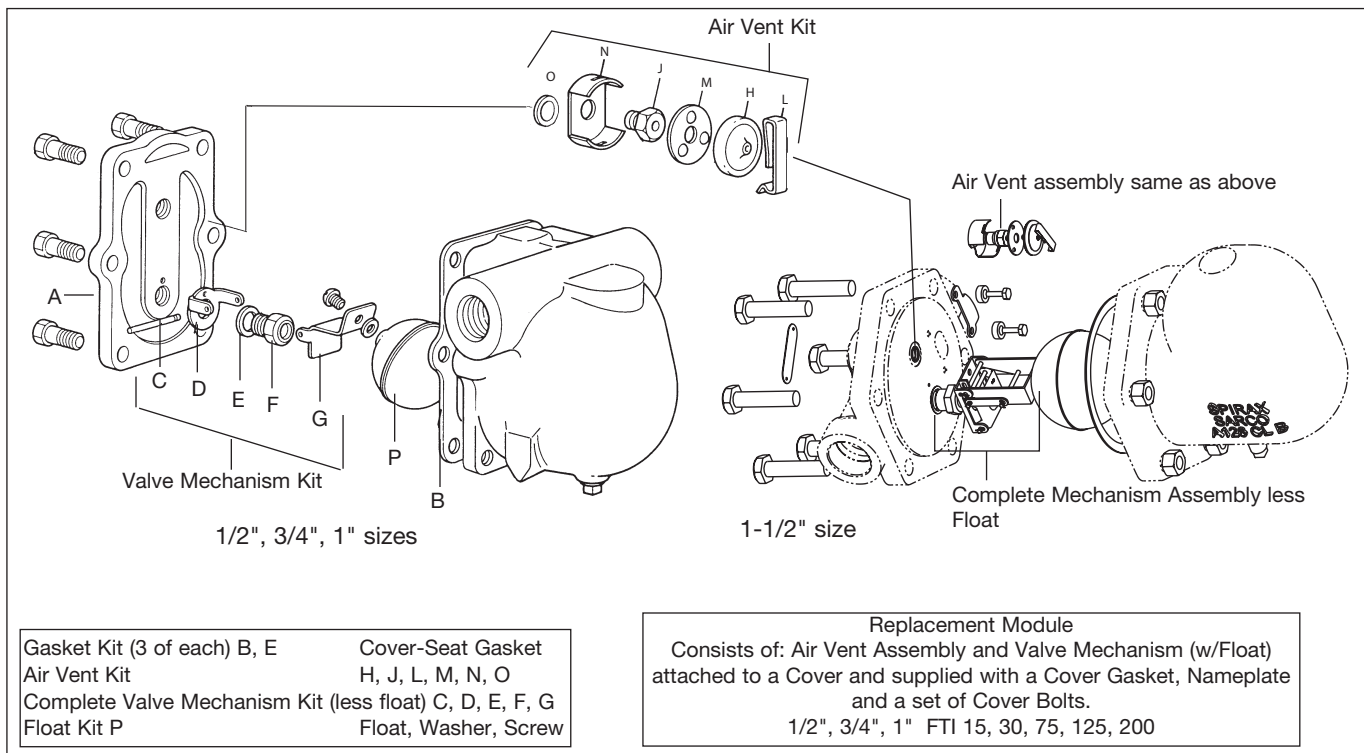

Gasket Kit (3 of each) B, E
Air Vent Kit
Complete Valve Mechanism Kit (less float) C, D, E, F, G
Float Kit P
Cover-Seat Gasket
H, J, L, M, N, O
Float, Washer, Screw

Replacement Module
Consists of: Air Vent Assembly and Valve Mechanism (w/Float) attached to a Cover and supplied with a Cover Gasket, Nameplate and a set of Cover Bolts.
1/2", 3/4", 1" FTI 15, 30, 75, 125, 200

TI-2-321-US 2.14