

APT14, APT14HC and APT14SHC Automatic Pump Traps

Installation and Maintenance Instructions

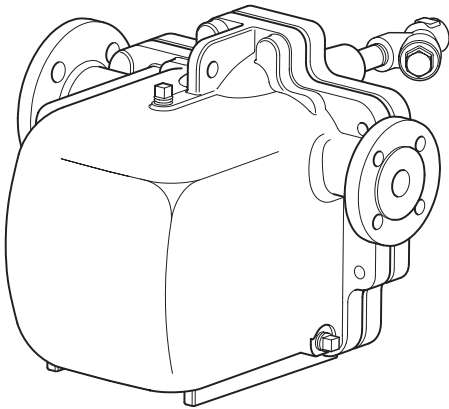



1. Safety information
2. Product information
3. Operation
4. Installation
 - Closed loop steam systems only
5. Commissioning
6. Maintenance
7. Replacement of spares (1):
 - Cover gasket
 - Inlet swing check valve
 - Spring and actuator arm
 - Floats
8. Replacement of spares (2):
 - Trap and outlet check valve mechanism
 - Steam inlet/exhaust valves and seats
9. Fault finding guide

1. Safety information

Safe operation of these products can only be guaranteed if they are properly installed, commissioned, used and maintained by qualified personnel (see Section 1.11) in compliance with the operating instructions. General installation and safety instructions for pipeline and plant construction, as well as the proper use of tools and safety equipment must also be complied with.

1.1 Intended use

Referring to the Installation and Maintenance Instructions, name-plate and Technical Information Sheet, check that the product is suitable for the intended use/application.

The products listed below fully comply with the requirements of the Pressure Equipment Directive (PED), ATEX Directive 94/9/EC and carry the  and  marks when so required.

The products fall within the following Pressure Equipment Directive categories:

Product	Group 1 Liquids	Group 2 Gases	Group 1 Gases	Group 2 Liquids	
APT14	-	1	-	SEP	
APT14HC	-	2	-	SEP	
APT14SHC	-	2	-	SEP	
DCV10	DN40 PN25 rated	-	SEP	-	SEP
	DN50 Class 300 rated	-	1	-	SEP
Motive strainer DN15	SEP	SEP	SEP	SEP	

Product marking per ATEX Directive 94/9/EC  II 2G CT3.

- i) The products have been designed for use on steam, air and water/condensate which are in Group 2 of the above mentioned Pressure Equipment Directive. The products' use on other fluids may be possible but, if this is contemplated, Spirax Sarco should be contacted to confirm the suitability of the product for the application being considered.
- ii) Check material suitability, pressure and temperature and their maximum and minimum values. If the maximum operating limits of the product are lower than those of the system in which it is being fitted, or if malfunction of the product could result in a dangerous overpressure or overtemperature occurrence, ensure a safety device is included in the system to prevent such over-limit situations.
- iii) Determine the correct installation situation and direction of fluid flow.
- iv) Spirax Sarco products are not intended to withstand external stresses that may be induced by any system to which they are fitted. It is the responsibility of the installer to consider these stresses and take adequate precautions to minimise them.
- v) Remove protection covers including cardboard support flanges from all connections before installation.

1.2 Access

Ensure safe access and if necessary a safe working platform (suitably guarded) before attempting to work on the product. Arrange suitable lifting gear if required.

1.3 Lighting

Ensure adequate lighting, particularly where detailed or intricate work is required.

1.4 Hazardous liquids or gases in the pipeline

Consider what is in the pipeline or what may have been in the pipeline at some previous time. Consider: flammable materials, substances hazardous to health, extremes of temperature.

1.5 Hazardous environment around the product

Consider: explosion risk areas, lack of oxygen (e.g. tanks, pits), dangerous gases, extremes of temperature, hot surfaces, fire hazard (e.g. during welding), excessive noise, moving machinery.

1.6 The system

Consider the effect on the complete system of the work proposed. Will any proposed action (e.g. closing isolation valves, electrical isolation) put any other part of the system or any personnel at risk? Dangers might include isolation of vents or protective devices or the rendering ineffective of controls or alarms. Ensure isolation valves are turned on and off in a gradual way to avoid system shocks.

1.7 Pressure systems

Ensure that any pressure is isolated and safely vented to atmospheric pressure. Consider double isolation (double block and bleed) and the locking or labelling of closed valves. Do not assume that the system has depressurised even when the pressure gauge indicates zero.

1.8 Temperature

Allow time for temperature to normalise after isolation to avoid danger of burns.

1.9 Tools and consumables

Before starting work ensure that you have suitable tools and/or consumables available. Use only genuine Spirax Sarco replacement parts.

1.10 Protective clothing

Consider whether you and/or others in the vicinity require any protective clothing to protect against the hazards of, for example, chemicals, high/low temperature, radiation, noise, falling objects, and dangers to eyes and face.

1.11 Permits to work

All work must be carried out or be supervised by a suitably competent person.

Installation and operating personnel should be trained in the correct use of the product according to the Installation and Maintenance Instructions.

Where a formal 'permit to work' system is in force it must be complied with. Where there is no such system, it is recommended that a responsible person should know what work is going on and, where necessary, arrange to have an assistant whose primary responsibility is safety.

Post 'warning notices' if necessary.

1.12 Handling

Manual handling of large and/or heavy products may present a risk of injury. Lifting, pushing, pulling, carrying or supporting a load by bodily force can cause injury particularly to the back. You are advised to assess the risks taking into account the task, the individual, the load and the working environment and use the appropriate handling method depending on the circumstances of the work being done.

Please note

For specific details relating to the weight and internal mechanism of these products, see Section 2.

Product specific - safe lifting information

Please note that the Spirax Sarco APT14 automatic pump trap units come complete with holes which may be tapped or untapped. These holes may be used for lifting purposes at the sole risk and responsibility of the purchaser.

The purchaser is responsible for the selection and use of the correct eye-bolt or shackle combination and is, in whole, responsible for all lifting operations and operator competency at their location. Spirax Sarco will ensure that any tapped hole will have a spot face larger than the shoulder of a standard eye-bolt to allow seating down to the shoulder. However, it should not be assumed that an eye-bolt is suitable for lifting the product simply on the basis of shoulder size.

Spirax Sarco will accept no responsibility for loss or damage real or imagined, caused by incorrect or inappropriate lifting of our products.

Spirax Sarco will ensure that the tapped holes provided are clearly marked with the exact size and thread form. We will also carry out in conjunction with a third party, a test on a sample of each product so provided and make available a copy of the test procedure and test certificate on request.

Furthermore and without obligation Spirax Sarco will attach to each product provided with such holes, threaded or otherwise, a disclaimer affixed to the product explaining the purchaser's duty under the LOLER regulations for safe off-loading and lifting of the product at their premises.

1.13 Residual hazards

In normal use the external surface of the product may be very hot. If used at the maximum permitted operating conditions the surface temperature of these products may reach temperatures of 200 °C (392 °F).

These products are not self-draining. Take due care when dismantling or removing the product from an installation (refer to 'Maintenance instructions').

1.14 Freezing

Provision must be made to protect products which are not self-draining against frost damage in environments where they may be exposed to temperatures below freezing point.

1.15 Disposal

Unless otherwise stated in the Installation and Maintenance Instructions, this product is recyclable and no ecological hazard is anticipated with its disposal providing due care is taken.

1.16 Returning products

Customers and stockists are reminded that under EC Health, Safety and Environment Law, when returning products to Spirax Sarco they must provide information on any hazards and the precautions to be taken due to contamination residues or mechanical damage which may present a health, safety or environmental risk. This information must be provided in writing including Health and Safety data sheets relating to any substances identified as hazardous or potentially hazardous.

2. General product information

2.1 General description

The Spirax Sarco automatic pump trap is a flanged or screwed displacement receiver pressure rated to PN16. The unit is capable of automatically trapping or pumping, depending on pipeline conditions. The unit is operated by steam and is used to remove condensate from process plant under all operating conditions including vacuum.

Design compliance

The shell of the product has been designed in accordance with A.D. Merkblatter/ASME VIII.



Optional extra

Both the APT14 and APT14HC are available with the **body and cover coated with electroless nickel plate (ENP)**. This option, when required, will be denoted as **APT14 ENP** and **APT14HC ENP** respectively and must be stated at the time of order placement.

The APT14, APT14HC and APT14SHC are available with the body drilled, tapped and plugged to accept sight level gauges. **Note:** Sight level gauges can not be fitted retrospectively to the standard APT14, APT14HC or APT14SHC.

Sight level gauges, supplied separately, are available for the APT14, APT14HC or APT14SHC. For further details contact Spirax Sarco.

Standards

These products fully comply with the requirements of the Pressure Equipment Directive (PED), ATEX Directive 94/9/EC and carry the  and  marks when so required.

Certification

These products are available with certification to EN 10204 3.1. **Note:** All certification/inspection requirements must be stated at the time of order placement.

2.2 Sizes and pipe connections

Model and body material	Inlet and outlet sizes and pipe connections	Motive/exhaust		
APT14 SG iron	Flanged DN40 inlet x DN25 outlet	EN 1092 PN16	BSP or NPT	DN15 (½")
		ASME B 16.5 (ANSI) 150	NPT	DN15 (½")
		JIS 10 (JIS B 2210)	BSP	DN15 (½")
		KS 10 (KS B 1511)	BSP	DN15 (½")
	Screwed 1½" inlet x 1" outlet	BSP (BS 21 parallel)	BSP	DN15 (½")
		NPT	NPT	DN15 (½")
APT14HC SG iron	Flanged DN50 inlet x DN40 outlet	EN 1092 PN16	BSP	DN15 (½")
		ASME B 16.5 (ANSI) 150	NPT	DN15 (½")
APT14SHC Carbon steel	Flanged DN50 inlet x DN40 outlet	JIS 10 (JIS B 2210)	BSP	DN15 (½")
		KS 10 (KS B 1511)	BSP	DN15 (½")

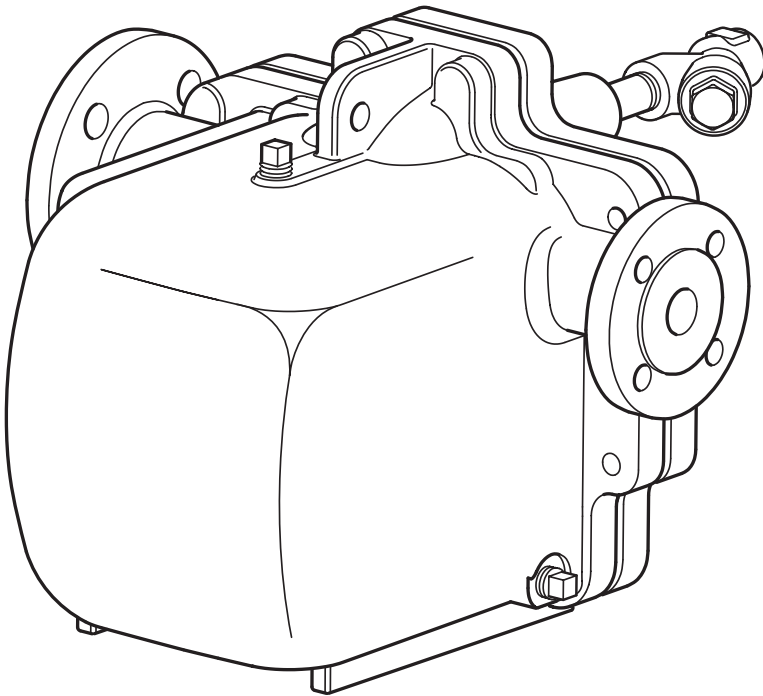
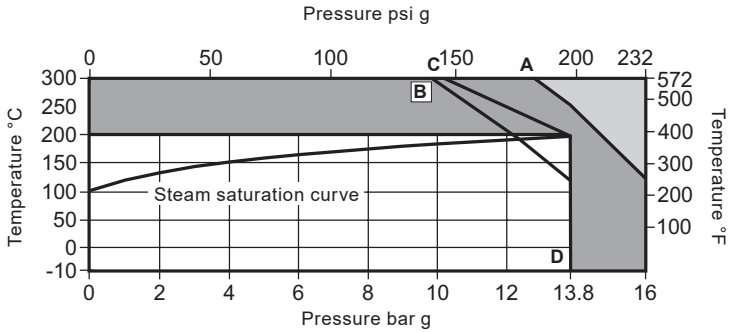

Fig. 1 APT14 shown

APT14, APT14HC and APT14SHC Automatic Pump Traps

2.3 Pressure/temperature limits - APT14 and APT14HC (SG iron) - see Section 2.4 for the APT14SHC



The product **must not** be used in this region.

The product should not be used in this region or beyond its operating range as damage to the internals may occur.

- A - D Flanged PN16.
- B - D Flanged JIS/KS 10.
- C - D Flanged ANSI 150.

Body design conditions		PN16
Maximum motive inlet pressure		13.8 bar g (200 psi g)
PMA	Maximum allowable pressure	16 bar g @ 120 °C (232 psi g @ 248 °F)
TMA	Maximum allowable temperature	300 °C @ 12.8 bar g (572 °F @ 186 psi g)
Minimum allowable temperature Note: For lower temperatures consult Spirax Sarco.		-10 °C (14 °F)
PMO	Maximum operating pressure for saturated steam service	13.8 bar g @ 198 °C (200 psi g @ 388 °F)
Maximum backpressure - for standard pumps Note: For higher backpressures contact Spirax Sarco		5 bar g (72.5 psi g)
TMO	Maximum operating temperature for saturated steam service	198 °C @ 13.8 bar g (388 °F @ 200 psi g)
Minimum operating temperature Note: For lower temperatures consult Spirax Sarco.		-10 °C (14 °F)
Temperature limits (Ambient )		-10 °C to 200 °C (14 °F to 392 °F)
Designed for a maximum cold hydraulic test pressure of:		24 bar g (348 psi g)
	Recommended filling head above the pump (from the base of the receiver/process)	0.3 m (12")
Filling/ Installation head	Maximum recommended installation head (from the base of the pump) for higher installation heads refer to Spirax Sarco	1 m (39")
	Minimum installation head required (from the base of the pump)	0.2 m (8")

APT14, APT14HC and APT14SHC Automatic Pump Traps

2.4 Pressure/temperature limits - APT14SHC (Carbon steel) - see Section 2.3 for the APT14 and APT14HC

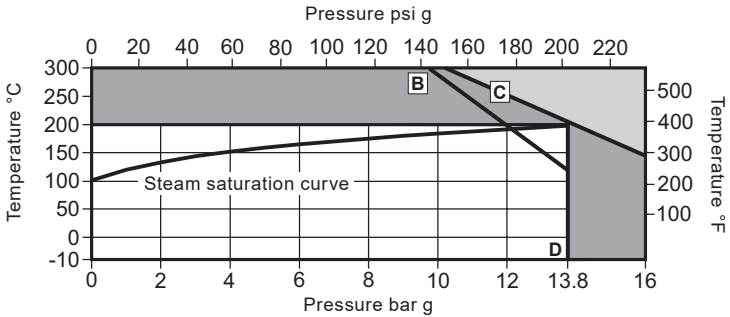
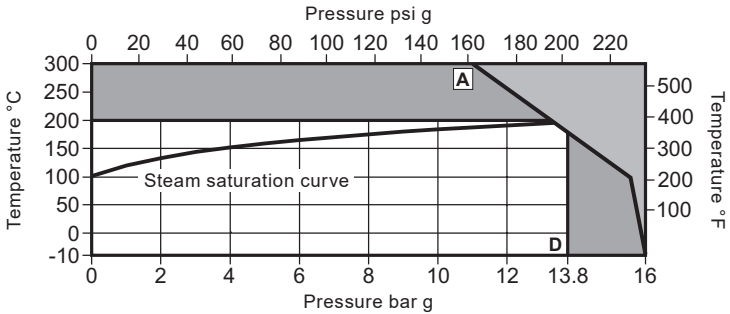

The product **must not** be used in this region.

The product should not be used in this region or beyond its operating range as damage to the internals may occur.

A - D Flanged PN16.

B - D Flanged JIS/KS 10.

C - D Flanged ANSI 150.

Body design conditions		PN16
Maximum motive inlet pressure		13.8 bar g (200 psi g)
PMA	Maximum allowable pressure	16 bar g @ 120 °C (232 psi g @ 248 °F)
TMA	Maximum allowable temperature	300 °C @ 12.8 bar g (572 °F @ 186 psi g)
Minimum allowable temperature Note: For lower temperatures consult Spirax Sarco.		-10 °C (14 °F)
PMO	Maximum operating pressure for saturated steam service	13.8 bar g @ 198 °C (200 psi g @ 388 °F)
Maximum backpressure - for standard pumps Note: For higher backpressures contact Spirax Sarco		5 bar g (72.5 psi g)
TMO	Maximum operating temperature for saturated steam service	198 °C @ 13.8 bar g (388 °F @ 200 psi g)
Minimum operating temperature Note: For lower temperatures consult Spirax Sarco.		-10 °C (14 °F)
Temperature limits (Ambient )		-10 °C to 200 °C (14 °F to 392 °F)
Designed for a maximum cold hydraulic test pressure of:		24 bar g (348 psi g)
	Recommended filling head above the pump (from the base of the receiver/process)	0.3 m (12")
Filling/ Installation head	Maximum recommended installation head (from the base of the pump) for higher installation heads refer to Spirax Sarco	1 m (39")
	Minimum installation head required (from the base of the pump)	0.2 m (8")

APT14, APT14HC and APT14SHC Automatic Pump Traps

2.5 Nominal capacities

For full capacity details for a specific application consult Spirax Sarco. To accurately size the pump trap, the following data is required.

1. Installation head available, from the base of the pump trap to the centre line of the heat exchanger/ process condensate outlet (metres, feet or inches). If the outlet is mounted vertically, then this should be from the base of the pump to the face of the outlet.
2. Motive steam pressure available to power the pump trap (bar g or psi g).
3. Total backpressure in the condensate return system (bar g or psi g).
4. Heat exchanger full-load operating pressure (bar g or psi g).
5. Heat exchanger maximum steam load (kg/h or lb/h).
6. Minimum temperature of secondary fluid. (°C).
7. Maximum controlled temperature of secondary fluid (°C or °F).

Model	APT14	APT14HC and APT14SHC
Pump discharge/cycle	5 litres (1.1 gallons)	8 litres (1.76 gallons)

2.6 Dimensions / weights

Metric (approximate) in mm and kg

Model		A	B	C	D	E	F	G	H	I		J	Weight
		PN16 ANSI											
APT14	Screwed	350	198	246	385	304	258	57	250	-	-	198	45
	Flanged	389	198	246	385	304	258	57	250	-	-	198	45
APT14HC	Flanged	476	198	270	400	335	261	57	275	31.5	45	198	65
APT14SHC	Flanged	508	206	278	407	351	261	57	275	31.5	45	206	105

Imperial (approximate) in inches and lbs

APT14	Screwed	13.78	7.8	9.69	15.16	11.97	10.16	2.24	9.84	-	-	7.80	99.26
	Flanged	15.31	7.8	9.69	15.16	11.97	10.16	2.24	9.84	-	-	7.80	99.26
APT14HC	Flanged	18.74	7.8	10.63	15.75	13.19	10.27	2.24	10.83	1.24	1.77	7.80	143.33
APT14SHC	Flanged	99.9	8.1	10.94	16.62	13.82	10.27	2.24	10.83	1.24	1.77	8.11	231.53

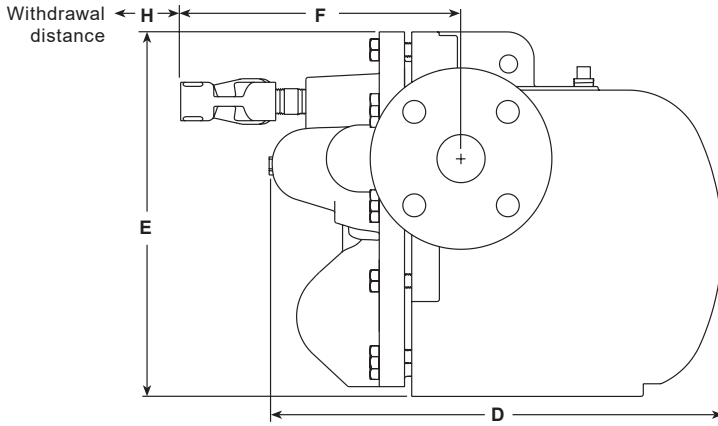

Note:

Installation of a DN40 outlet check valve type DCV10 is required for the APT14HC and APT14SHC only

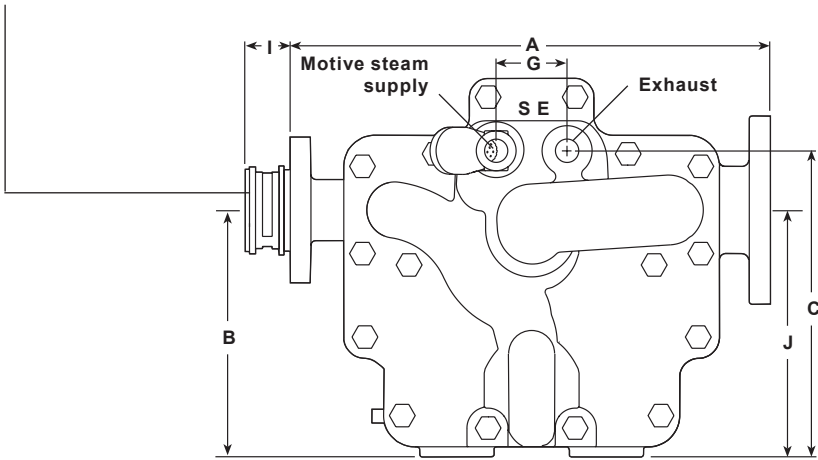

Fig. 2

2.7 Materials

No.	Part	Material	
1	Cover	APT14	SG iron EN JS 1025 or ASTM A395
		APT14HC	SG iron EN JS 1025 or ASTM A395
		APT14SHC	Carbon steel EN 1.0619+N or ASTM A216 WCB
2	Cover gasket	Graphite laminated with stainless steel insert	
3	Body	APT14	SG iron EN JS 1025 or ASTM A395
		APT14HC	SG iron EN JS 1025 or ASTM A395
		APT14SHC	Carbon steel EN 1.0619+N or ASTM A216 WCB
4	Cover bolts	Stainless steel	ISO 3506 Gr. A2 70
	4 x location pins (APT14SHC only)	Stainless steel	304
5	Pump lever	Stainless steel	BS 1449 304 S15
6	Float	Stainless steel	BS 1449 304 S15
7	Trap lever	Stainless steel	BS 1449 304 S15
8	Trap 2nd stage valve	Stainless steel	ASTM A276 440 B
9	Trap housing	Stainless steel	BS 3146 ANC 2
10	Ball (APT14 only)	Stainless steel	ASTM A276 440 B
11	Seat (inlet check valve)	Stainless steel	AISI 420
12	Flap (inlet check valve)	Stainless steel	BS 3146 ANC 4B
13	Pump mechanism bracket	Stainless steel	BS 3146 ANC 4B
14	Spring (pump)	Stainless steel	BS 2056 302 S26 Gr. 2
15	Split pin	Stainless steel	BS 1574
16	Exhaust seat	Stainless steel	BS 970 431 S29 or ASTM A276 431

For parts 17 to 29, go to pages 16 and 17

Fig. 3

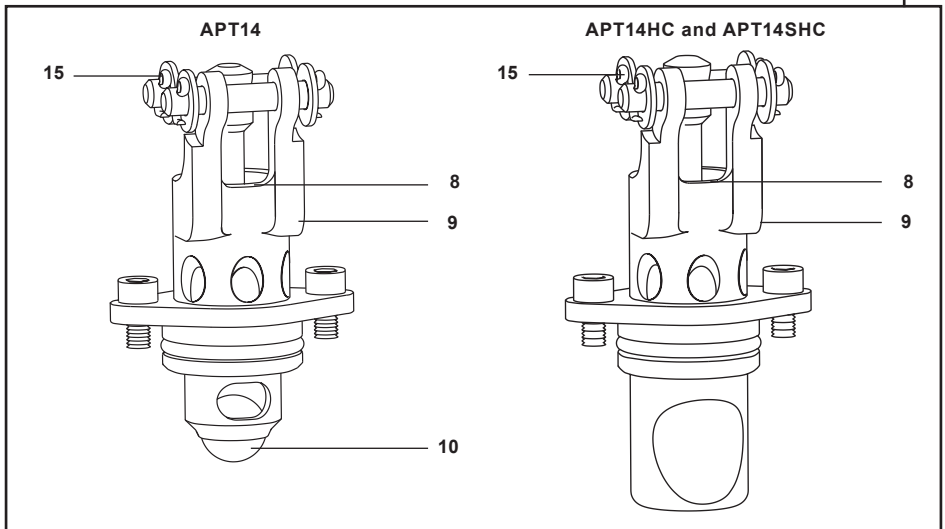
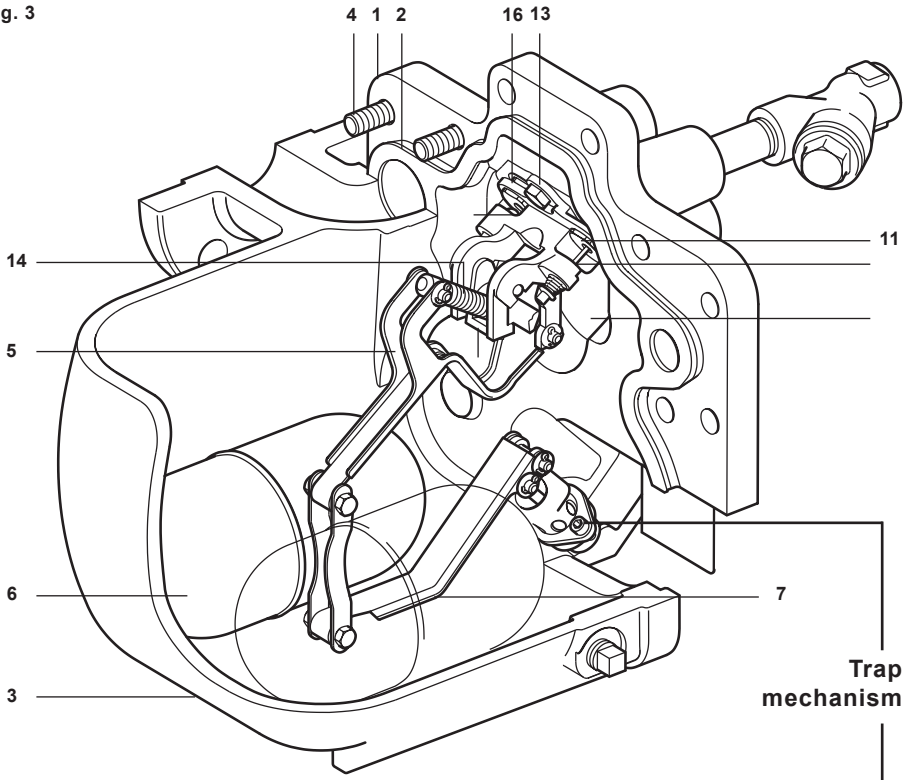

APT14, APT14HC and APT14SHC Automatic Pump Traps

For parts 1 to 16, go to pages 14 and 15

2.8 Materials

No.	Part	Material	
17	Inlet valve and seat assembly	Stainless steel	
18	Exhaust valve	Stainless steel	BS 3146 ANC 2
19	Valve seat gasket	Stainless steel	BS 1449 409 S19
20	Pump mechanism bolt	Stainless steel	ISO 3506 Gr. A2 70
21	Trap housing bolt	Stainless steel	BS 6105 A4 80
22	Trap 1st stage valve	Stainless steel	BS 970 431 S29 or ASTM A276 431
23	'O' ring	EPDM	
24	Actuator arm	Stainless steel	BS 3146 ANC 2
25	Name-plate	Stainless steel	BS 1449 304 S16
26	Drain plug	Steel	DIN 17440 1.4571
27	Inlet valve spring	Stainless steel	
28	Motive strainer	APT14	SG iron
		APT14HC	SG iron
		APT14SHC	Carbon steel
29	DCV10 (APT14HC and APT14SHC only)	Stainless steel (not shown)	

2.9 Disposal

There are no hazardous materials used in the construction of this product. Any unwanted material should be recycled or disposed of in an environmentally friendly manner as specified in Section 1, Safety information.

Fig. 4

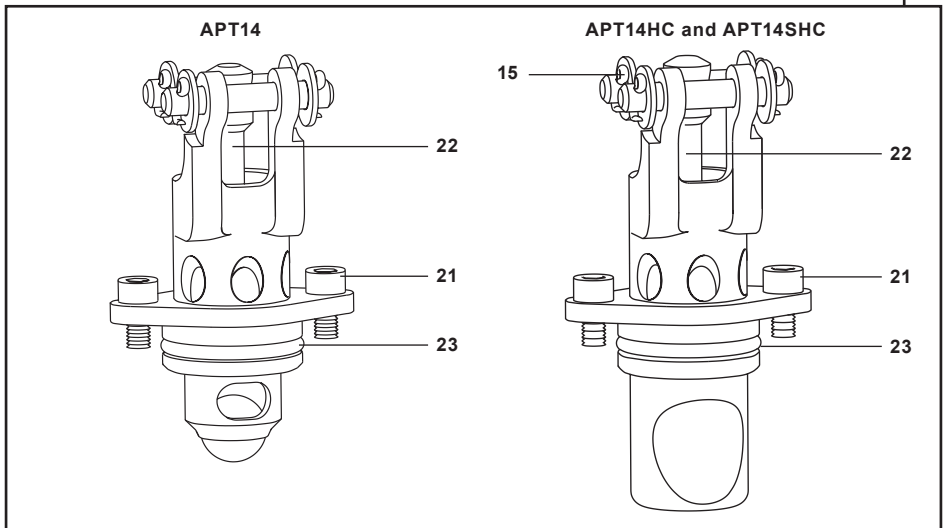
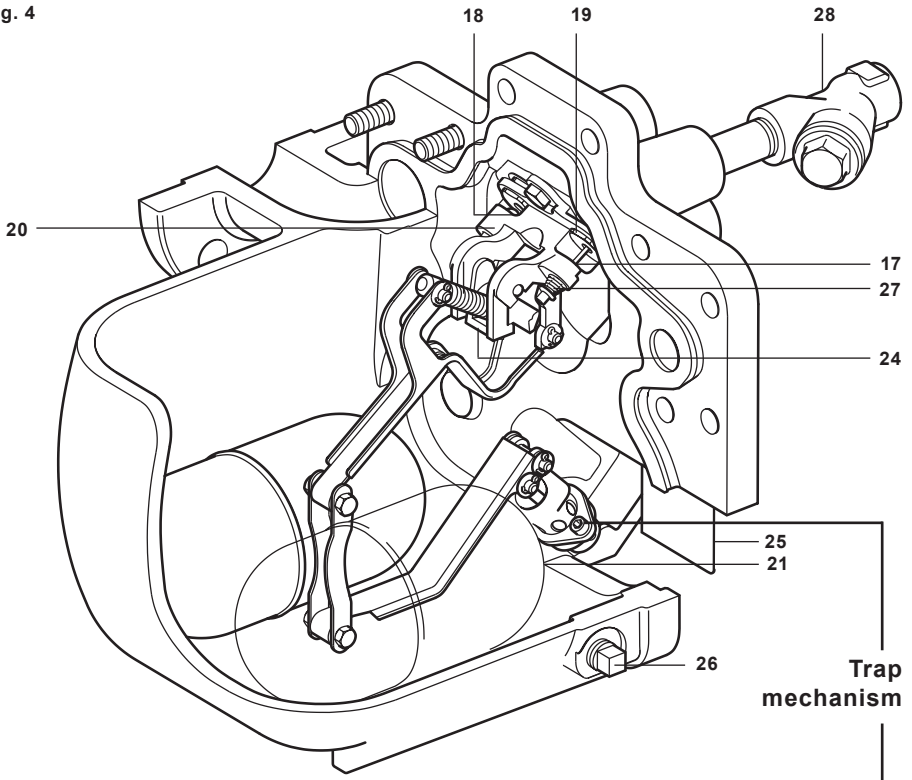

APT14, APT14HC and APT14SHC Automatic Pump Traps

3. Operation

Step 1 (Figure 5)

The APT14, APT14HC and APT14SHC automatic pump trap operates on a positive displacement principle. Condensate enters the body through the inlet swing check valve causing the float to rise. The float is connected to the trap mechanism via a multi-link pivot. If the upstream system pressure PS is sufficient to overcome the backpressure PB (Figure 4), the build up of condensate will be discharged through the opening two stage trap mechanism.

In this way, the float will automatically modulate according to the rate of condensate entering the unit, controlling the rate of opening and closure of the trap.

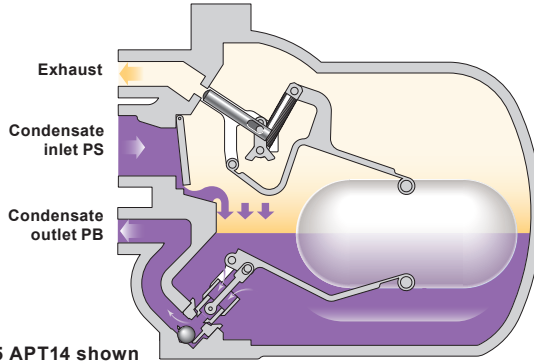

Fig. 5 APT14 shown

Step 2 (Figure 6)

With some temperature controlled equipment, it is possible for the system pressure PS to be lower than the backpressure at PB (Figure 6).

If this occurs a standard trap will stall allowing the condensate to flood the equipment being drained.

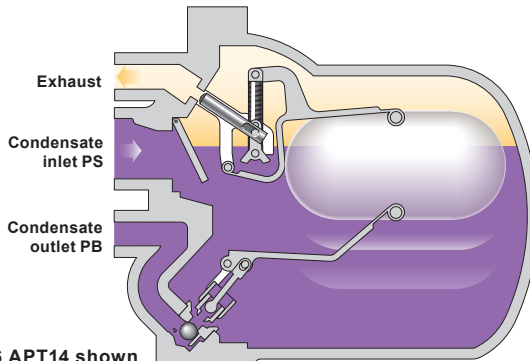

Fig. 6 APT14 shown

Step 3 (Figure 7)

However, with the APT14, APT14HC and APT14SHC, the condensate simply fills the main chamber - lifting the float until the changeover linkage is engaged, opening the motive inlet and closing the exhaust valve.

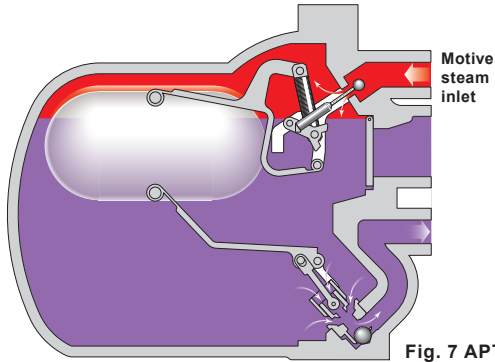

Fig. 7 APT14 shown

Step 4 (Figure 8)

The snap action mechanism ensures a rapid change from the trapping mode to the active pumping mode. With the motive inlet valve open, the pressure in the APT14, APT14HC and APT14SHC increases above the total backpressure and the condensate is forced out through the trap seat into the plant's return system.

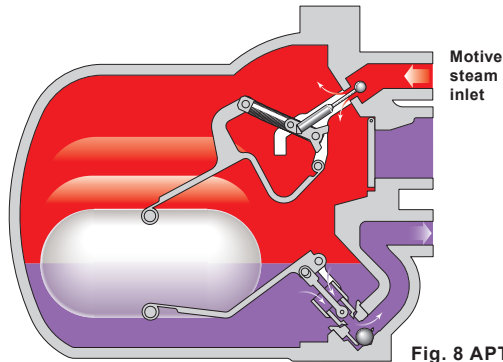

Fig. 8 APT14 shown

Steps continued on the next page

APT14, APT14HC and APT14SHC Automatic Pump Traps

spirax
sarco

Step 5 (Figure 9)

As the condensate level falls within the main chamber, the float re-engages the change over linkage, causing the motive inlet to close and the exhaust valve to open.

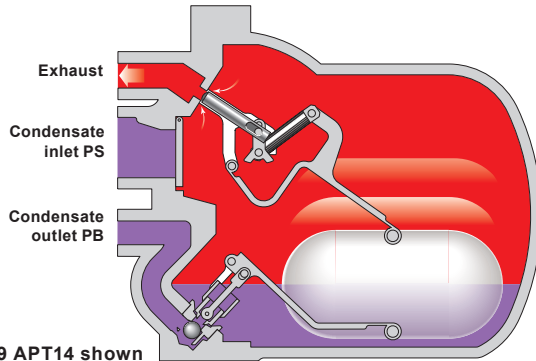

Fig. 9 APT14 shown

Step 6 (Figure 10)

As the pressure inside the APT14 equalises with the condensate inlet pressure through the open exhaust valve, condensate re-enters via the inlet swing check valve. At the same time the outlet ball check valve (APT14 only) ensures no condensate can drain back into the main chamber and the trapping or pumping cycle begins again.

Note: The APT14HC and APT14SHC requires an external Spirax Sarco DN40 disc check valve to be fitted to the condensate outlet, between the flanges.

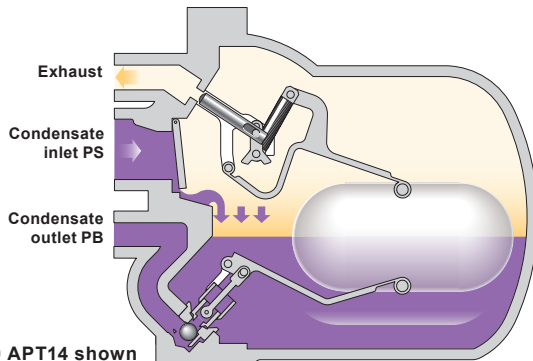

Fig. 10 APT14 shown

Return to Step 1

4. Installation

Important - safety note

Please read Section 1.12 regarding the safe lifting of this product before actioning any installation or maintenance procedure.

Before any installation or maintenance procedure, always ensure that all steam or condensate lines are isolated.

Ensure any residual internal pressure in the product or connecting lines is carefully relieved. Also ensure any hot parts have cooled to prevent risk of injury from burns. Always wear appropriate safety clothing before carrying out any installation or maintenance work.

Note: If pumping a potentially explosive media, the motive supply media must be an inert gas with no oxygen present.

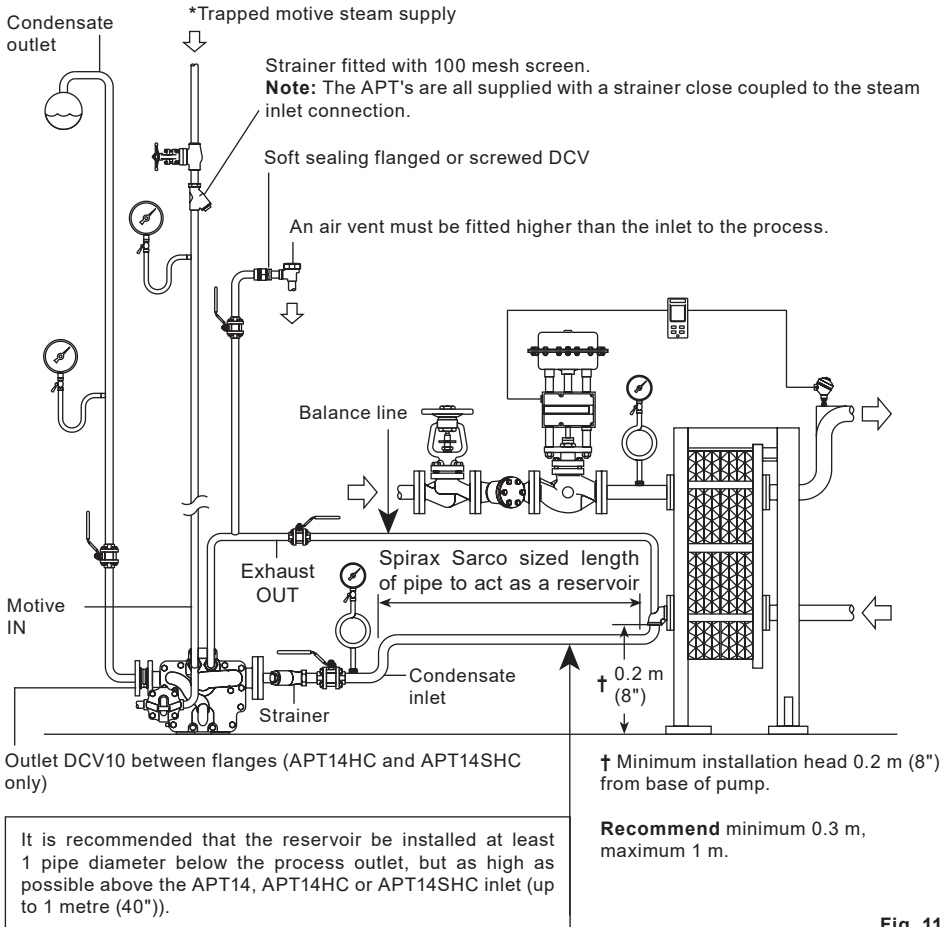

Fig. 11

4.1 Inlet piping

To prevent condensate backing up into the equipment being drained, it is recommended that the inlet pipework is sufficiently sized to accumulate condensate during the pump's discharge cycle. Generally a length and diameter of pipe to accommodate the following condensate capacity will be sufficient: 4 litres (1.1 gallons) for an APT14 or 8 litres (1.76 gallons) for an APT14HC and APT14SHC. It is recommended this condensate reservoir is situated at least 1 pipe diameter below the process outlet but as high as possible above the APT inlet (up to 1 metre (40")). It is essential that a Spirax Sarco Y-type strainer is fitted at the condensate inlet of the APT14, APT14HC and APT14SHC, as shown in Figure 12.

4.2 Recommended installation head

An installation head of at least 0.3 m (12 ins) from the base of the unit is recommended. Minimum 0.2 m (8") with reduced capacity; Maximum 1 m (40"). **Note:** During cold start-up conditions, it is possible for hydraulic pulsing of the inlet check valve to occur. It is advisable in this case to install a throttling isolation valve to reduce the filling pressure.

4.3 Connections (refer to the installation diagram, Figure 12)

The APT's have four connection ports. The DN40 (1½") - APT14 or DN50 (2") - APT14HC and APT14SHC port should be connected to the outlet of the equipment being drained. The DN25 (1") - APT14 or DN40 (1½") APT14HC and APT14SHC port should be connected to the condensate return line. Flow arrows indicate the correct direction of flow. The DN15 (½") port marked (S) should be connected to a trapped motive steam supply. *** It is important to ensure this line is drained of condensate at all times using a Spirax Sarco steam trap and filtered using a 100 mesh strainer as fitted (see Figure 11).** The screwed DN15 (½") port marked (E) should be balanced back as close as possible to the condensate outlet of the equipment. This balance line must always be connected to the top of the condensate pipe, as shown in Figure 11. **Note:** If a thermal cut out device has been installed to protect the heat exchanger from excess temperature, then it is important this is mounted upstream of the steam control valve and the take-off point for the motive steam supply to the APT14, APT14HC or APT14SHC.

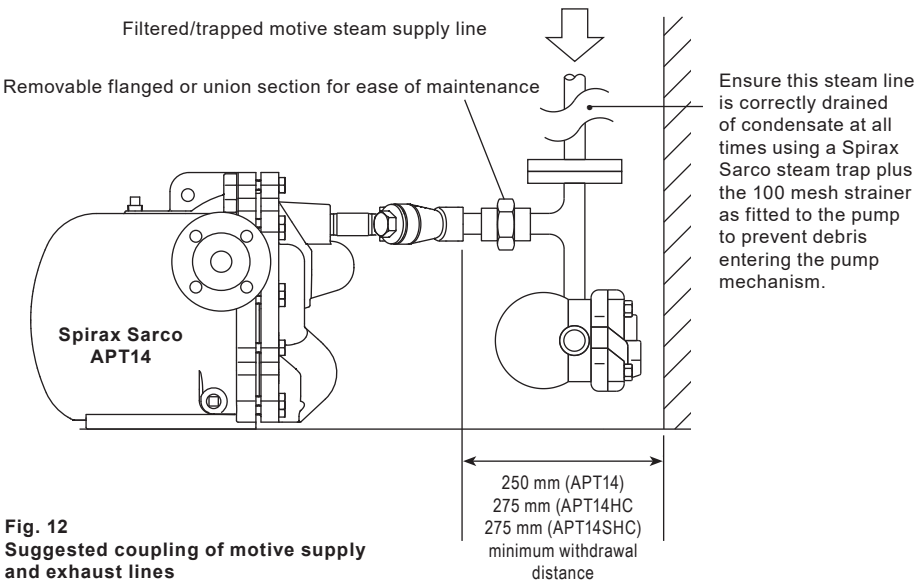

Fig. 12
Suggested coupling of motive supply and exhaust lines

4.4 Outlet piping

It is important for the outlet piping to be correctly sized to prevent excessive backpressure on the APT14, APT14HC or APT14SHC. This pipework should be sized to take into account the effects of flash steam at the heat exchangers full load operating conditions and any other equipment being discharged into the return line.

Note: A separate Spirax Sarco DN40 DCV10 check valve must be fitted to the outlet flange of the pump body and the connecting pipework flange - APT14HC and APT14SHC only. Ensure the DCV10 is mounted centrally between the flanges with the directional flow arrow pointing in the direction of fluid flow. A gasket should be used both sides of the disc check valve. For all other maintenance and technical information see IM-P601-32.

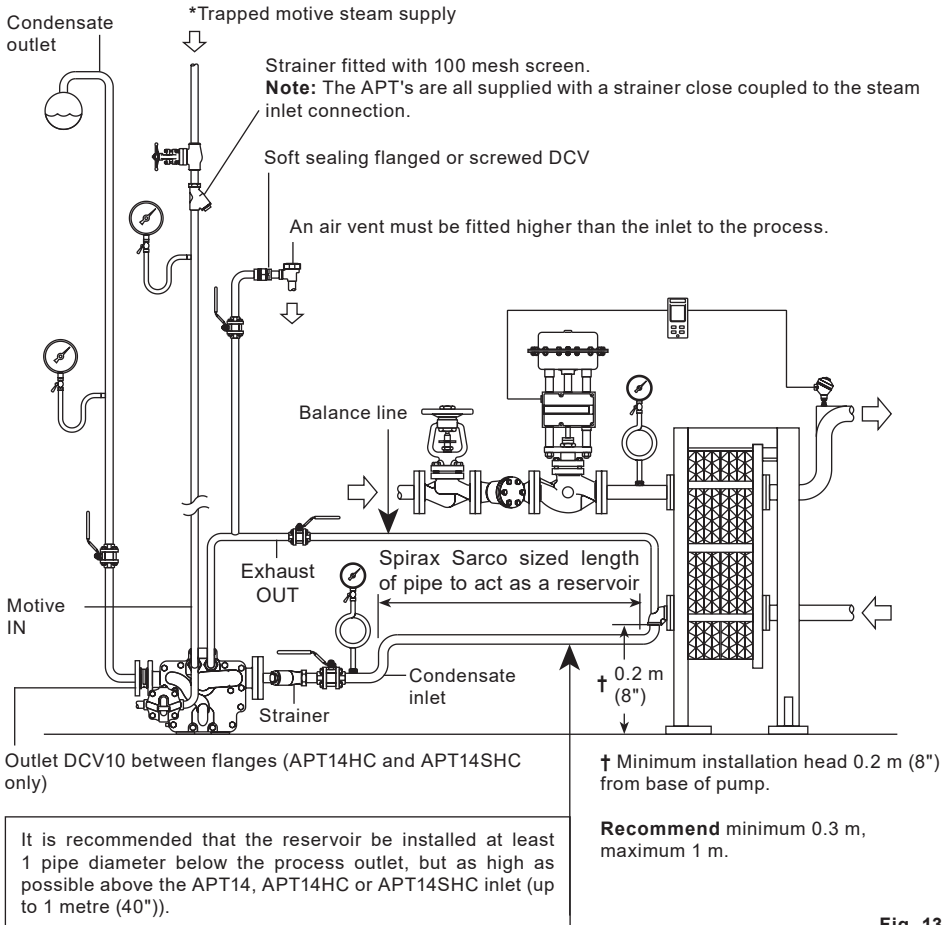

Fig. 13

4.5 Pressure gauges

It is recommended that system pressure gauges are fitted to the motive supply, condensate inlet and condensate outlet as shown in Figure 14.

4.6 Control of motive supply pressure

Although the APT is able to utilise motive pressures up to 13.8 bar g (200 psi g), it is highly recommended that the motive pressure does not exceed 3 to 4 bar g (44 to 58 psi g) above the backpressure applied to the pump. When specifying a pressure reducing valve to reduce the motive supply pressure, the effects of pulsating flow on the pressure reducing valve must be considered. Contact Spirax Sarco for details of recommended installation if required. The motive supply must be drained by a suitable steam trap to ensure the motive steam is dry. See Figure 14.

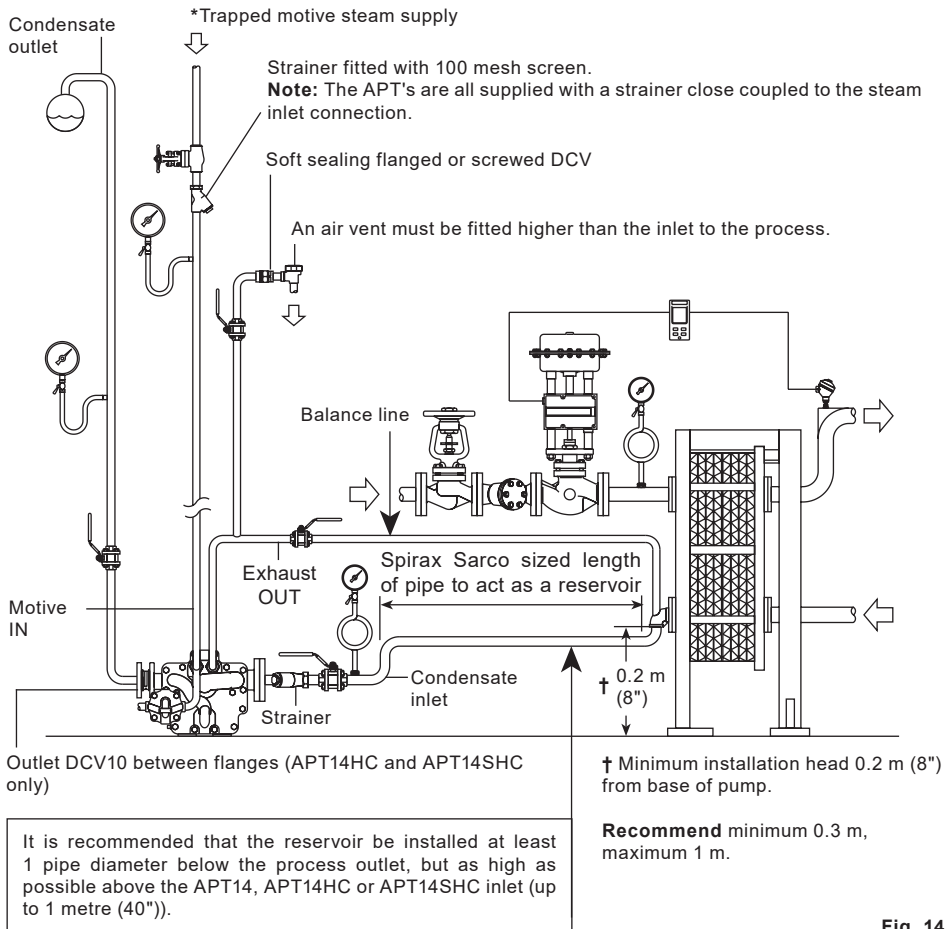

Fig. 14

4.6.1 Fail safe condition of motive supply.

When the APT14 is used to remove condensate from temperature controlled plant such as heat exchangers, it is recommended that the motive supply to the APT is taken from a point downstream of a fail safe high limit control valve, see Figure 15.

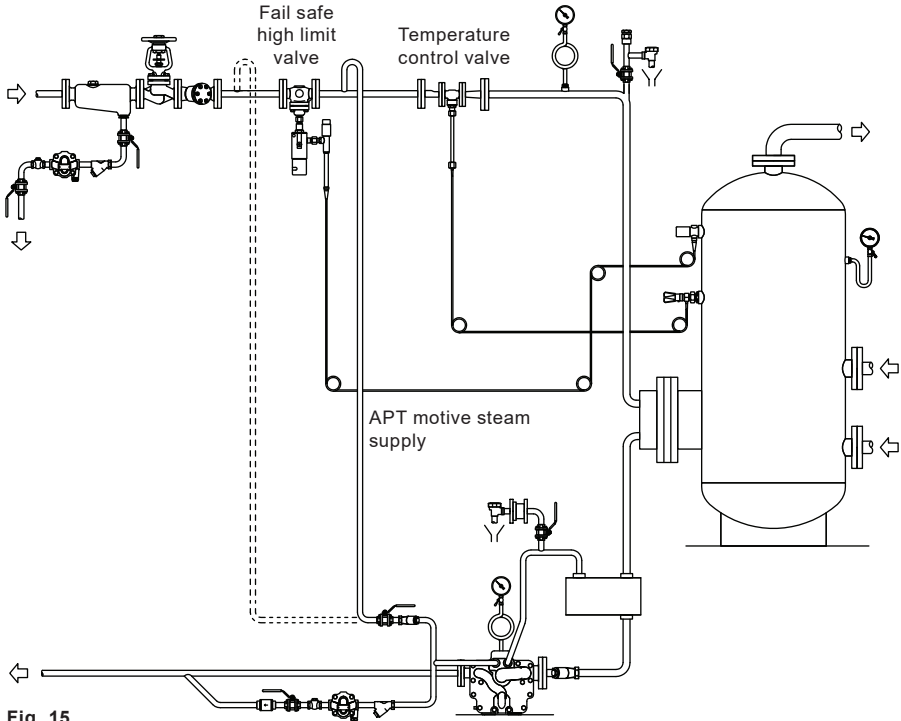

Fig. 15

5. Commissioning

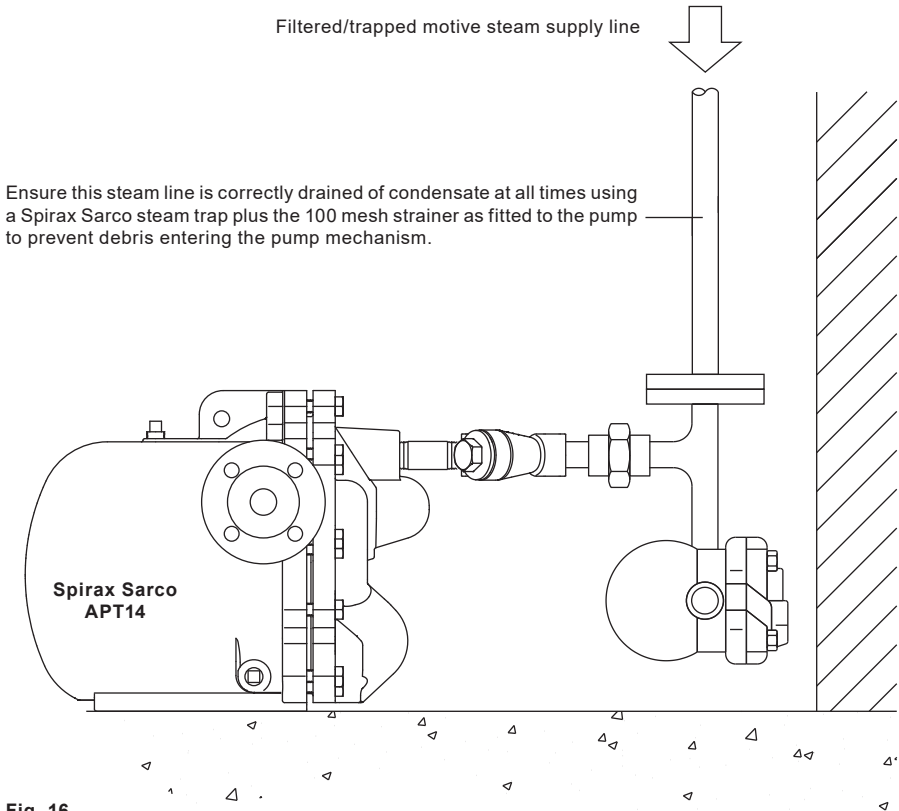

Fig. 16

- 5.1** After ensuring the inlet and outlet pipe connections and motive/exhaust connections are coupled in accordance with Figures 15 and 16, slowly open the motive steam inlet line to supply pressure to the APT14, APT14HC or APT14SHC. Ensure the exhaust/balance line is open and not restricted in any way.
- 5.2** Slowly open the isolation valves in the condensate inlet and discharge lines, allowing condensate to fill the body of the APT14, APT14HC or APT14SHC.
- 5.3** The APT14, APT14HC or APT14SHC is now ready to operate.
- 5.4** When the process plant is operational, the APT14, APT14HC or APT14SHC will discharge condensate under all pressure conditions into the return line.
- 5.5** If any irregularities are observed, recheck the installation according to the recommendations in Section 4. If the unit fails to operate, then consult the fault finding guide Section 9.

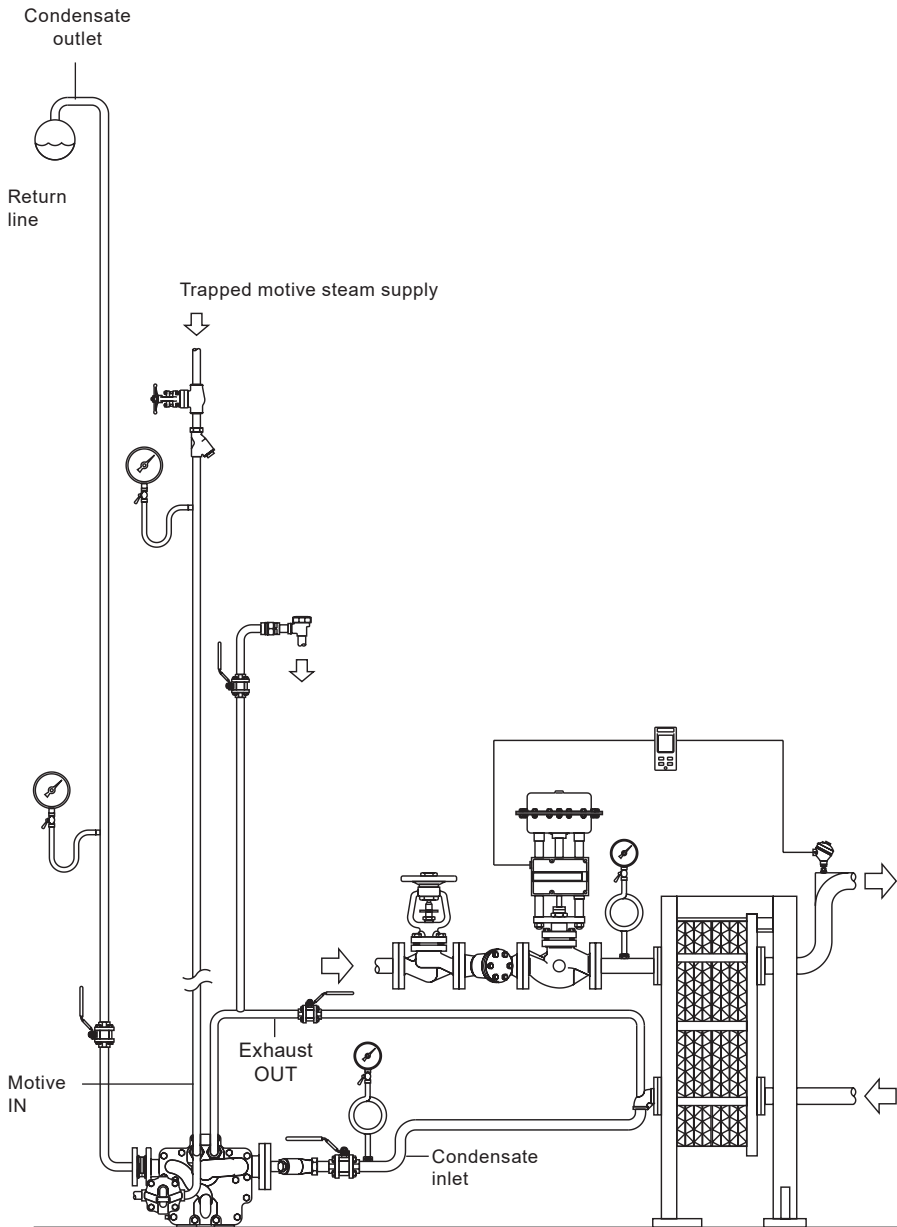

Fig. 17 APT14HC shown

APT14, APT14HC and APT14SHC Automatic Pump Traps

6. Maintenance

6.1 Mechanisms inspection and repair (Important - safety note)

Please read Section 1.12 regarding the safe lifting of this product before actioning any installation or maintenance procedure.

Before any installation or maintenance procedure, always ensure that all steam or condensate lines are isolated.

Ensure any residual internal pressure in the product or connecting lines is carefully relieved. Also ensure any hot parts have cooled to prevent risk of injury from burns.

Always wear appropriate safety clothing before carrying out any installation or maintenance work. When dismantling this product, care should be taken to prevent injury from the snap action mechanism. Always handle with care.

The APT14, APT14HC and APT14SHC should be inspected periodically, intervals dependant on application. Contact Spirax Sarco for details.

6.2 Removal and fitting of cover assembly

Please ensure the safety recommendations are observed before commencing with any maintenance of this product.

6.3 To remove the cover assembly

1. Disconnect all connections to the cover. Remove the cover bolts using the correct size socket, then carefully slide the cover assembly away from the body (a minimum withdrawal distance of 250 mm for the APT14 or 275 mm for the APT14HC and APT14SHC will be needed). Lift the cover assembly to a bench or other convenient working surface and clamp securely, avoiding contact with the gasket face.
2. Visually inspect the mechanism for obvious damage. Check that it is free of dirt and scale and operates freely when the floats are moved up and down.
3. Inspect the spring assembly for damage. Make sure the valves slide freely and the spring loaded exhaust valve moves on its guide.
4. Inspect the floats to ensure they are undamaged. Check they pivot smoothly on the pump and trap levers and they are not waterlogged.
5. Ensure the inlet swing check valve is free to move and the sealing faces of both the seat and the flap are clean and undamaged. (If the seat is badly scored or damaged a new cover assembly may be required).
6. Check the two stage trap module to ensure both the 1st and 2nd stage valves are free from dirt and debris. Ensure they slide open and close smoothly.
7. It is not possible to visually check the outlet check valve without removing the trap module (refer to Section 8 of this manual for correct removal and fitting of this part - APT14 only).
8. If any of the parts appear damaged or fail to work correctly, then refer to Sections 8 and 9 of this manual for correct removal and fitting instructions.

6.4 If a new cover assembly is to be fitted

1. Ensure the gasket face in the body is clean and free from debris. Carefully slide the new cover assembly into the existing body, whilst ensuring the new gasket (item 2) is carefully aligned with the gasket faces and no parts of it are trapped or pinched outside the sealing areas. To ensure accurate alignment of the cover and body, it is recommended the lower part of the cover's gasket seal is located into the body first. The top part of the seal can then be easily aligned.
2. Refit the cover bolts ensuring they are sequentially tightened in opposing pairs, gradually increasing torque to $63 \pm 5 \text{ N m}$ ($46.5 \pm 4 \text{ lbf ft}$).

Bolt size
M12 x 45

Socket size
19 mm A/F

Tightening torque
 $63 \pm 5 \text{ N m}$ ($46.5 \pm 4 \text{ lbf ft}$)

3. Carefully reconnect the motive steam supply and the exhaust lines to the connections marked (S) and (E), then follow the start-up procedure in **Section 5 'Commissioning'** to bring the APT14, APT14HC or APT14SHC back into operation.
4. Make sure that the Spirax Sarco motive supply strainer (with 100 mesh screen) is reinstated to the motive supply connection (item 28, Figure 3, page 13).

6.5 Spare parts

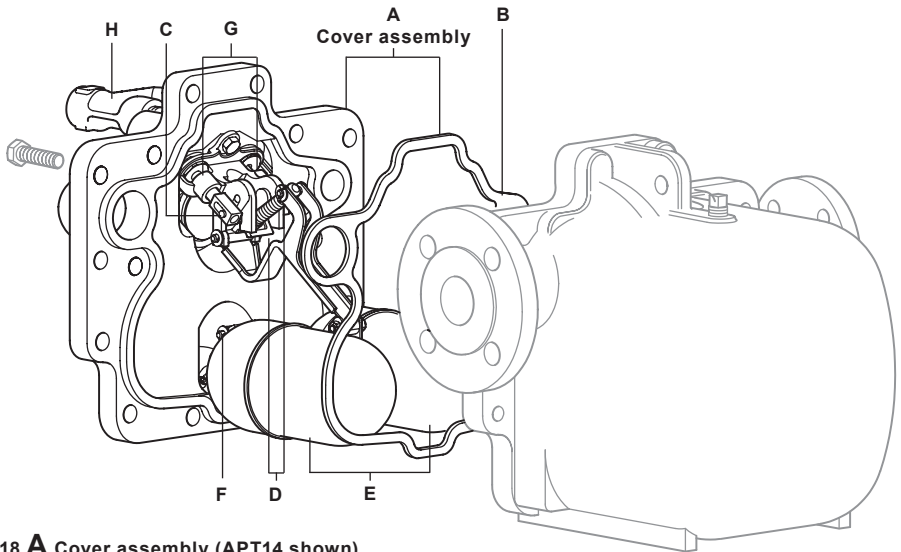

Fig. 18 **A** Cover assembly (APT14 shown)

Available spares

A Cover assembly (A - G inclusive)

1, 2, 5-25

Note: Refer to Figure 3, page 13 for component number details. For customer convenience, spares are supplied in kits to ensure all the appropriate replacement parts are available.

Spare parts 'B' to 'G' are shown on the next page

APT14, APT14HC and APT14SHC Automatic Pump Traps

spirax
sarco

6.5 Spare parts (continued)

Available spares

B	Cover gasket	2
C	Inlet check valve	2, 12
D	Spring and actuator arm	2, 14, 24
E	Floats	2, 5, 6, 7
F	Trap and outlet check valve mechanism	2, 8, 9, 10 (APT14 only), 21, 22, 23
G	Inlet/exhaust valve and seat kit	2, 16, 17, 18, 19, 27
H	100 mesh strainer screen and cap gasket for the Fig 12/14 strainer (see IM-S60-17)	28
DCV10 outlet check valve for the APT14HC and APT14SHC only (see IM-P601-32)		29

Note: Refer to Figure 3, page 13 for component number details. For customer convenience, spares are supplied in kits to ensure all the appropriate replacement parts are available.

B Cover gasket

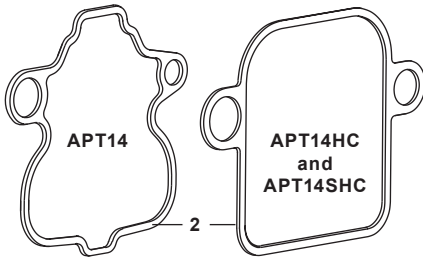

C Inlet check valve

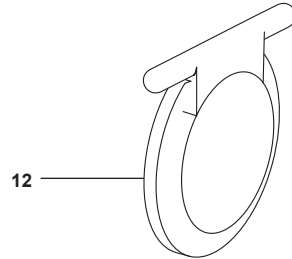

D Spring and actuator arm

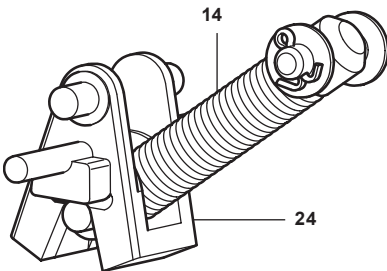

E Floats

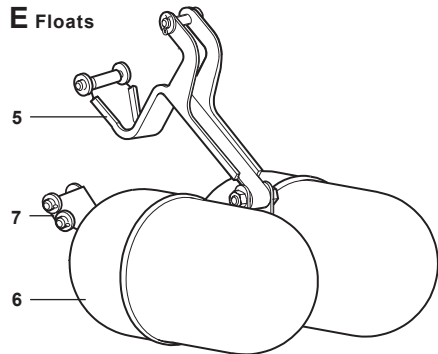

APT14, APT14HC and APT14SHC Automatic Pump Traps

F Trap and outlet check valve mechanism (APT14 only)

Note: Item 10 is not included for the APT14HC or APT14SHC

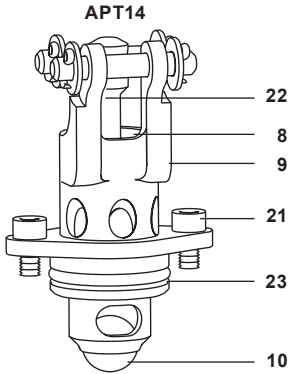

G Inlet/exhaust valve and seat kit

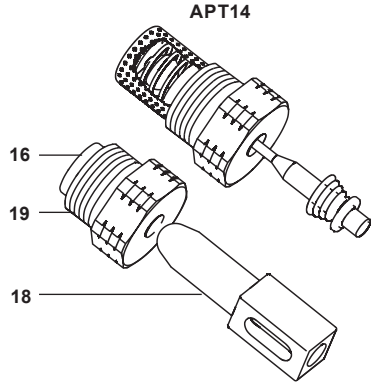

APT14HC and APT14SHC

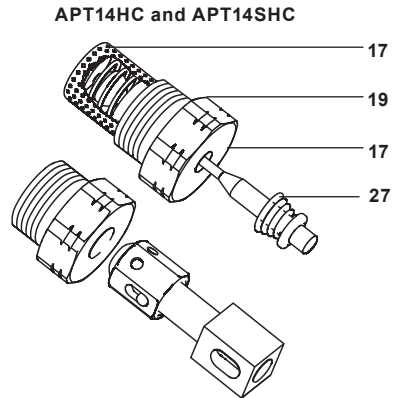
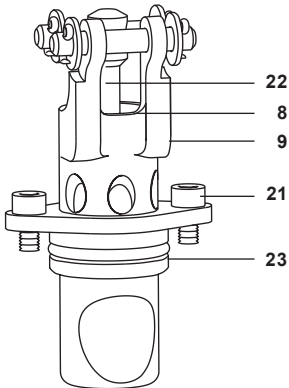

7. Replacement of spares (1)

Section 7 covers the replacement of the following spares:- cover gasket, inlet swing check valve, spring and actuator arm and floats.

Important - safety note

Please read Section 1.12 regarding the safe lifting of this product before actioning any installation or maintenance procedure.

Before any installation or maintenance procedure, always ensure that all steam or condensate lines are isolated.

Ensure any residual internal pressure in the product or connecting lines is carefully relieved. Also ensure any hot parts have cooled to prevent risk of injury from burns.

Always wear appropriate safety clothing before carrying out any installation or maintenance work. When dismantling this product, care should be taken to prevent injury from the snap action mechanism.

Always handle with care.

7.1 Replacement of cover gasket

Please ensure the safety recommendations are observed before commencing with any maintenance of this product.

To fit the new cover gasket

1. Disconnect all connections to the cover. Remove the cover bolts using the correct size socket, then carefully slide the cover assembly away from the body (a minimum withdrawal distance of 250 mm for the APT14 or 275 mm for the APT14HC and APT14SHC will be needed). Lift the cover assembly to a bench or other convenient working surface and clamp securely, avoiding contact with the gasket face.
2. Gently remove used gasket material from the body and cover, being careful not to damage the gasket sealing faces.
3. Carefully fit a new gasket (item 2) into the existing body (See Figure 19).
4. **Refit the cover assembly to the body**, ensuring the gasket faces are carefully aligned and no parts of the gasket are trapped or pinched outside the sealing areas. To ensure accurate alignment of the cover and body, it is recommended the lower part of the cover's gasket seal is located into the body first. The top part of the seal can then be easily aligned.
5. Refit the cover bolts ensuring they are sequentially tightened in opposing pairs, gradually increasing torque to $63 \pm 5 \text{ N m}$ ($46.5 \pm 4 \text{ lbf ft}$).

Bolt size
M12 x 45

Socket size
19 mm A/F

Tightening torque
 $63 \pm 5 \text{ N m}$ ($46.5 \pm 4 \text{ lbf ft}$)

6. Carefully reconnect the motive steam supply and the exhaust lines to the connections marked (S) and (E). The APT14, APT14HC or APT14SHC is now ready to recommission.
7. Make sure that the Spirax Sarco motive supply strainer (with 100 mesh screen) is reinstated to the motive supply connection (item 28, Figure 20).

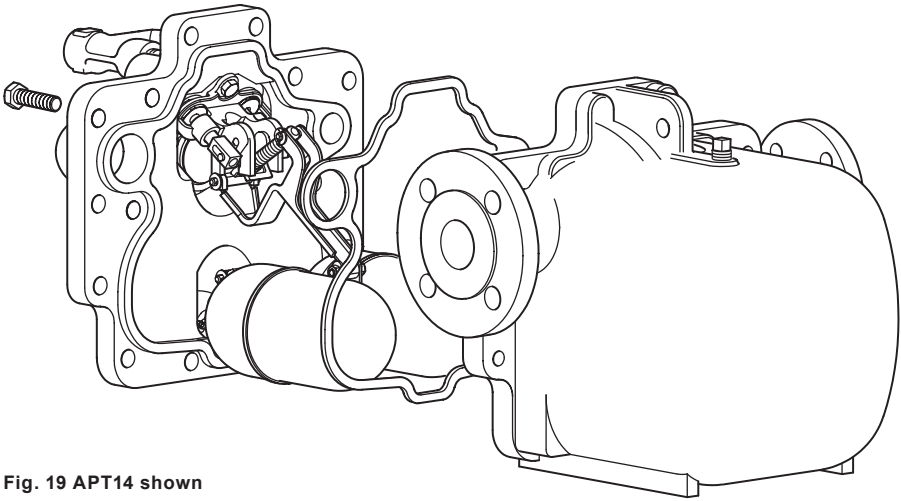

Fig. 19 APT14 shown

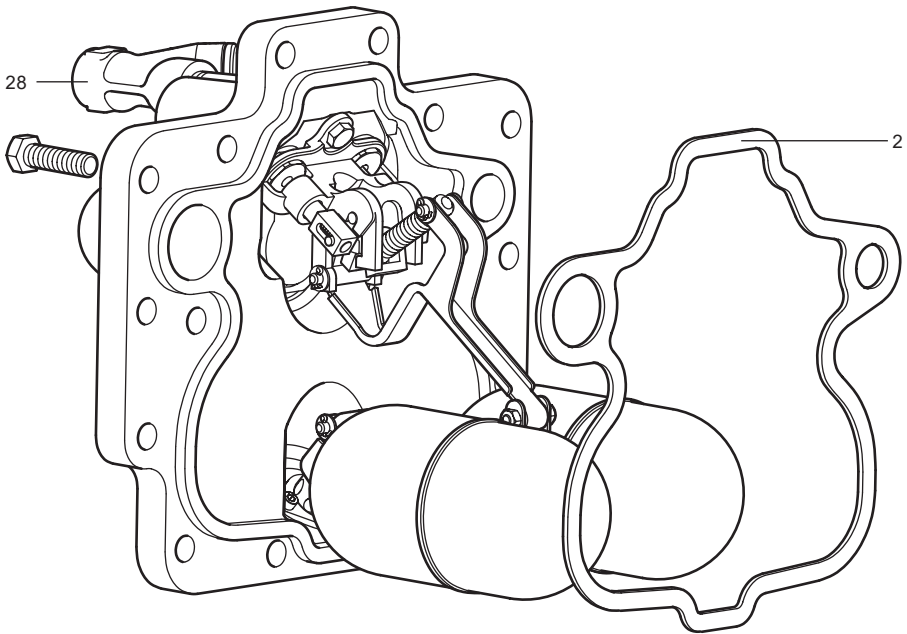

Fig. 20 APT14 shown

APT14, APT14HC and APT14SHC Automatic Pump Traps

7.2 Replacement of inlet swing check valve

Please ensure the safety recommendations are observed before commencing with any maintenance of this product.

To replace the inlet swing check valve

1. Remove the cover and old gasket (see cover gasket replacement procedure, Section 7.1).
2. Lift the cover assembly to a bench or other convenient working surface and clamp securely, avoiding contact with the gasket face.
3. Carefully remove the circlip, washer and the inlet valve spring (item 27) from the end of the steam inlet valve (item 17).
4. Remove the three M8 bolts that secure the pump mechanism bracket using the 13 mm A/F socket.
5. Lift away the pump bracket assembly (See Figure 20). This will allow access to the inlet swing check valve (item 12).
6. The swing check valve flap can now easily be withdrawn.
7. Fit a new flap, ensuring the face of the check valve flap and seat are clean and free from damage.
8. **Reassembly is the opposite to removal.**
9. Tighten the three M8 bolts using the 13 mm A/F socket to $18 \pm 2 \text{ N m}$ ($13 \pm 1.5 \text{ lbf ft}$).

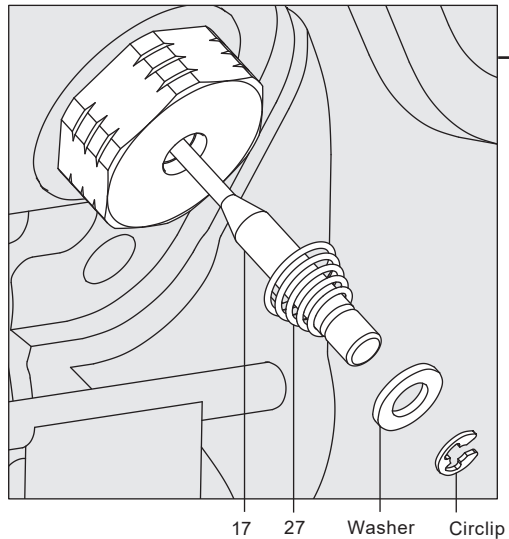
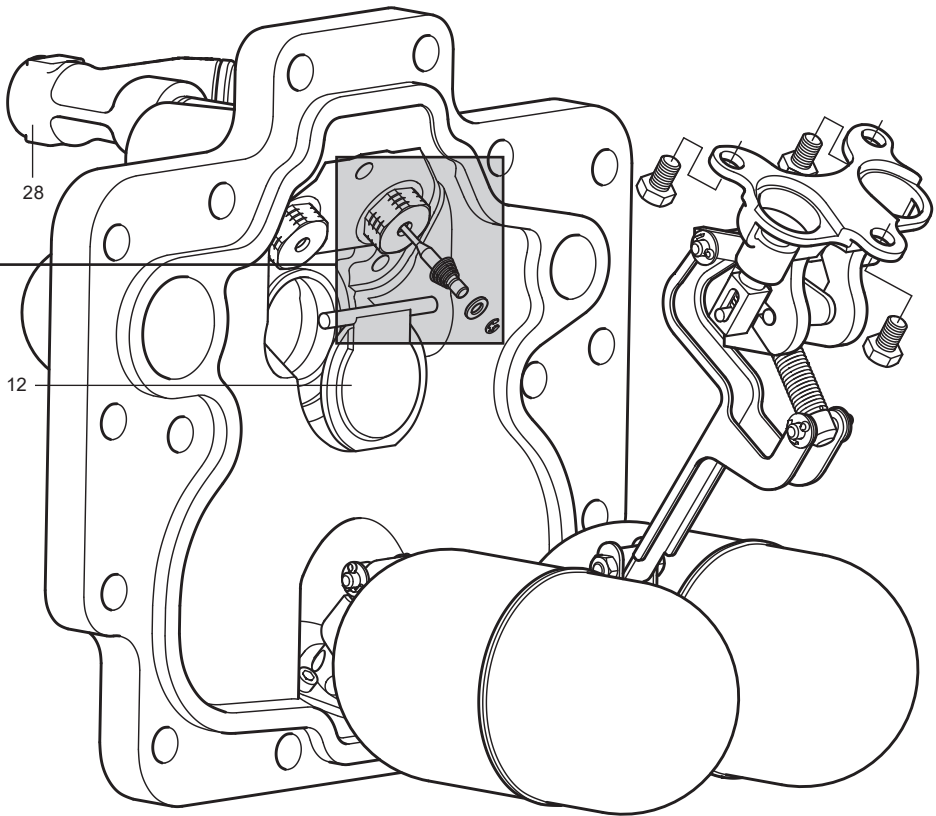

Fig. 21 APT14 shown

10. It is important to ensure a new circlip is refitted to the steam inlet valve.
11. With the mechanism fully assembled, refit the cover assembly to the body, ensuring the gasket faces are carefully aligned and no parts of the gasket are trapped or pinched outside the sealing areas. To ensure accurate alignment of the cover and body, it is recommended the lower part of the cover's gasket seal is located into the body first. The top part of the seal can then be easily aligned.
12. Refit the cover bolts ensuring they are sequentially tightened in opposing pairs, gradually increasing torque to $63 \pm 5 \text{ N m}$ ($46.5 \pm 4 \text{ lbf ft}$).
13. Carefully reconnect the motive steam supply and the exhaust lines to the connections marked (S) and (E). The APT14, APT14HC or APT14SHC is now ready to recommission.
14. Make sure that the Spirax Sarco motive supply strainer (with 100 mesh screen) is reinstated to the motive supply connection (item 28, Figure 21).



APT14, APT14HC and APT14SHC Automatic Pump Traps

7.3 Replacement of spring and actuator arm

Please ensure the safety recommendations are observed before commencing with any maintenance of this product.

To replace the spring and actuator arm

1. Remove the cover and old gasket (see cover gasket replacement procedure, Section 7.1).
2. Lift the cover assembly to a bench or other convenient working surface and clamp securely, avoiding contact with the gasket face.
3. Ensure the floats are at the bottom of their travel.
4. Remove split pins, washers, and shafts (X and Y) from the top spring pivot and pump pivot points (See Figure 22).
5. Remove the spring and anchor assembly.
6. Draw the actuator arm with the exhaust valve downwards within its slots until it becomes free. It may be necessary to slide the exhaust valve (item 18) backwards against its internal spring to free it from the pump bracket guide (item 13), see Figure 22.
7. Remove the exhaust valve from the actuator arm (item 24, shown in Figure 23) being careful not to damage or lose the small exhaust valve compression spring.
8. The spring assembly and actuator arm can both be replaced.

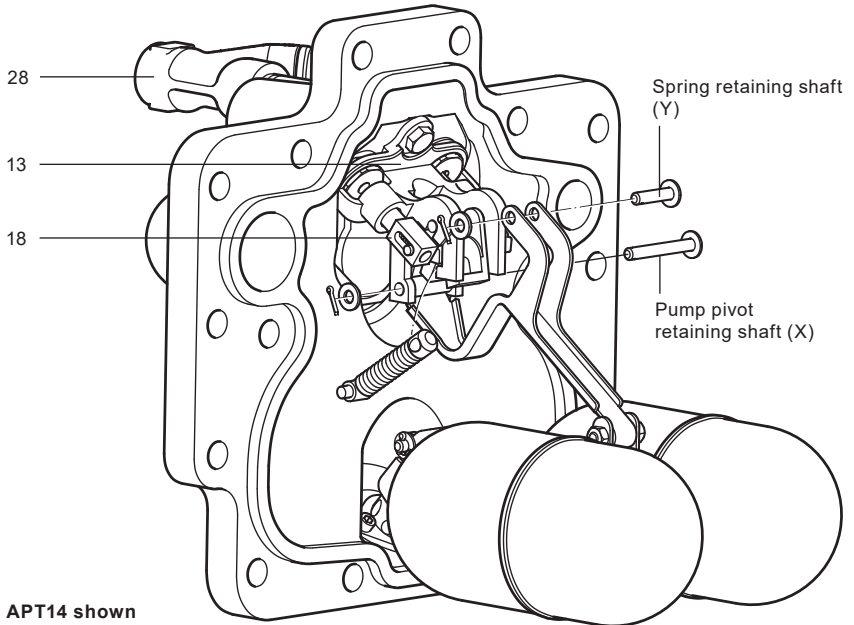

Fig. 22 APT14 shown

9. **Fitting the new spring assembly and actuator arm is the opposite to removal.** Remember to compress the small spring within the exhaust valve (item 18) before refitting to the spigot of the new actuator arm.
10. Ensure the actuator is correctly aligned and located within the slots of the pump bracket (item 13) (see Figure 22).
11. Once this is correctly located, ensure the exhaust valve can slide easily within its guides.
12. Always use new split pins and washers when refitting the spring retaining shaft (Y) and pump pivot shaft (X).
13. With the mechanism fully assembled, reposition the cover assembly with the body, ensuring the gasket faces are carefully aligned and no parts of the gasket are trapped or pinched outside the sealing areas. To ensure accurate alignment of the cover and body, it is recommended the lower part of the cover's gasket seal is located into the body first. The top part of the seal can then be easily aligned.
14. Refit the cover bolts ensuring they are sequentially tightened in opposing pairs, gradually increasing torque to $63 \pm 5 \text{ N m}$ ($46.5 \pm 4 \text{ lbf ft}$).
15. Carefully reconnect the motive steam supply and the exhaust lines to the connections marked (S) and (E). The APT14, APT14HC or APT14SHC is now ready to recommission.
16. Make sure that the Spirax Sarco motive supply strainer (with 100 mesh screen) is reinstated to the motive supply connection (item 28, Figure 22).

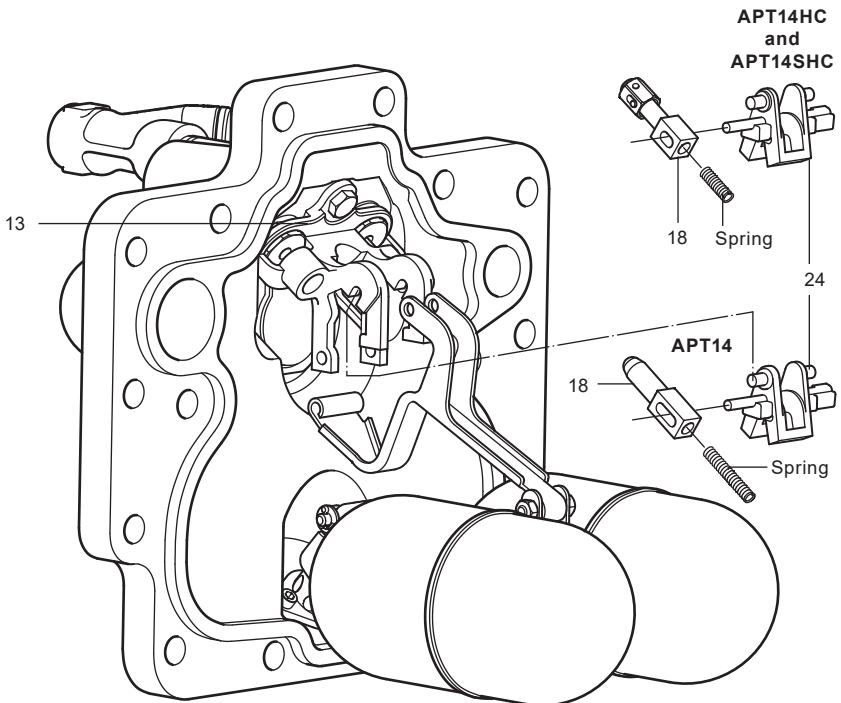

Fig. 23 APT14 shown

7.4 Replacement of floats

Please ensure the safety recommendations are observed before commencing with any maintenance of this product.

To replace the float and upper/lower levers

1. Remove the cover and old gasket (see cover gasket replacement procedure, Section 7.1).
2. Lift the cover assembly to a bench or other convenient working surface and clamp securely, avoiding contact with the gasket face.
3. Remove a split pin and washer from one side of the spring retaining shaft (Y) (See Figure 24).
4. Remove a split pin and washer from one side of pump pivot retaining shaft (X).
5. Carefully slide the shafts out from their respective positions observing the orientation of the spring and actuator arm (item 14, 24) within the pump bracket (item 13) as these will need to be refitted later.
6. Remove a split pin and washer from one side of the trap 1st stage valve retaining shaft (W).
7. Remove a split pin and washer from one side of the trap pivot retaining shaft (V).
8. The floats and lever assembly can now be removed and discarded as the replacement floats and levers are supplied fully assembled in the spares kit.
9. **Assembly is the opposite to removal.** Always fit new split pins and washers.

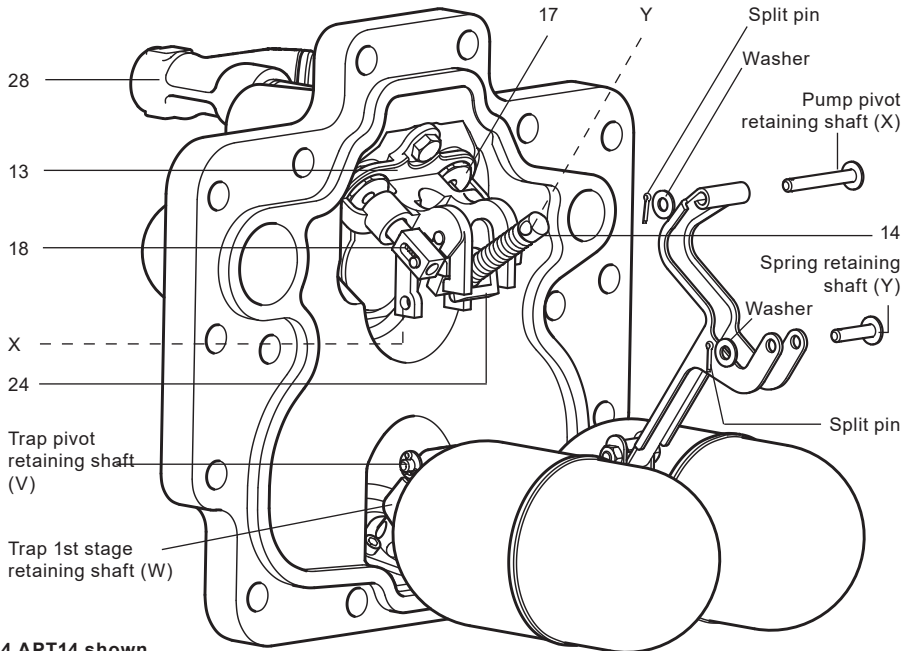

Fig. 24 APT14 shown

10. It is easier to fit the replacement shafts in the following sequence:- (See Figure 25).

V. Trap pivot shaft length 38 mm for both APT14, APT14HC and APT14SHC

W. Trap 1st stage valve ... shaft length 38 mm for both APT14, APT14HC and APT14SHC

X. Pump pivot shaft length 52 mm for both APT14, APT14HC and APT14SHC

Y. Spring retainer shaft length 30 mm for both APT14, APT14HC and APT14SHC

leaving the spring retaining shaft until after the spring and actuator arm have been correctly aligned and located within the slot of the pump bracket (item 13).

Ensure the spigot of the actuator arm is correctly engaged with the exhaust valve.

11. When all the shafts have been secured using new split pins and washers, move the floats to their upper and lower limits to ensure the mechanism operates smoothly and the spring and actuator arm snaps over to operate the motive steam inlet and exhaust valves (items 17, 18).

Note: The mechanism has been designed to be adjustment-free, simplifying the fitting of new parts. If after assembly the mechanism does not operate correctly, check all the parts are assembled and aligned as per the diagram.

12. With the mechanism fully assembled, refit the cover assembly to the body, ensuring the gasket faces are carefully aligned and no parts of the gasket are trapped or pinched outside the sealing areas. To ensure accurate alignment of the cover and body, it is recommended the lower part of the cover's gasket seal is located into the body first. The top part of the seal can then be easily aligned.

13. Refit the cover bolts ensuring they are sequentially tightened in opposing pairs, gradually increasing torque to $63 \pm 5 \text{ N m}$ ($46.5 \pm 4 \text{ lbf ft}$).

14. Carefully reconnect the motive steam supply and the exhaust lines to the connections marked (S) and (E). The APT14, APT14HC or APT14SHC is now ready to recommission.

15. Make sure that the Spirax Sarco motive supply strainer (with 100 mesh screen) is reinstated to the motive supply connection (item 28, Figure 24).

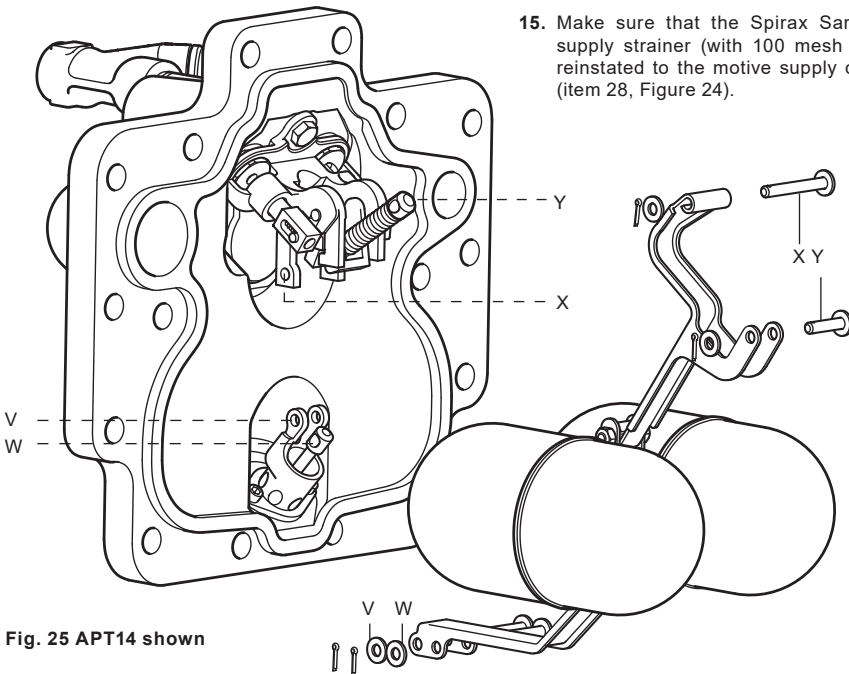

Fig. 25 APT14 shown

8. Replacement of spares (2)

Section 8 covers the replacement of the following spares:- trap (and outlet check valve APT14 only) mechanism and steam inlet/exhaust valves and seats.

Important - safety note

Please read Section 1.12 regarding the safe lifting of this product before actioning any installation or maintenance procedure.

Before any installation or maintenance procedure, always ensure that all steam or condensate lines are isolated.

Ensure any residual internal pressure in the product or connecting lines is carefully relieved. Also ensure any hot parts have cooled to prevent risk of injury from burns.

Always wear appropriate safety clothing before carrying out any installation or maintenance work. When dismantling this product, care should be taken to prevent injury from the snap action mechanism.

Always handle with care.

8.1 Replacement of trap (and outlet check valve - APT14 only) mechanism

Please ensure the safety recommendations are observed before commencing with any maintenance of this product.

To fit the new trap (and outlet check valve - APT14) mechanism

1. Disconnect all connections to the cover. Remove the cover bolts using a 19 mm A/F socket, then carefully slide the cover assembly away from the body (a minimum withdrawal distance of 250 mm for the APT14 or 275 mm for the APT14HC and APT14SHC will be needed). Lift the cover assembly to a bench or other convenient working surface and clamp securely, avoiding contact with the gasket face.
2. Gently remove used gasket material from the body and cover being careful not to damage the gasket sealing faces.
3. Carefully fit a new gasket (item 2) into the existing body.
4. Remove split pin, washer and shaft from the trap pivot (V) (See Figure 25).
5. Remove split pin, washer and shaft from the trap 1st stage valve (W).
6. The floats and levers (items 5, 6 ,7) can now be swung out of the way leaving access to the trap and check valve assembly.
7. Using the 4 mm Allen key unscrew the two M5 cap screws (item 21).
8. The whole trap (and check valve assembly APT14 only) can now be carefully withdrawn from the cover.
9. There are no serviceable parts within this assembly; the replacement spares kit contains all new parts.
10. Before fitting a new mechanism, clean the trap housing bore within the cover ensuring any sludge or scale is carefully removed and the 'O' ring sealing face is free from dirt.
11. **Assembly is the opposite to removal**, to ease fitting, the new 'O' ring must be lubricated with rubber lubricating emulsion such as International Products Corporation P-80.
12. Tighten the two M5 cap screws (item 21) to 5 ± 1 N m (4 ± 0.7 lbf ft).

13. Refit the two shafts (V and W) (length 38 mm) - remembering to use new split pins and washers - to the trap housing (item 9) and trap 1st stage valve (item 22).
14. Move the floats to their upper and lower limits to ensure the trap mechanism operates smoothly and both the 1st stage and 2nd stage valves (items 22, 8) slide smoothly within their guides.
15. With the mechanism fully assembled, refit the cover assembly to the body, ensuring the gasket faces are carefully aligned and no parts of the gasket are trapped or pinched outside the sealing areas. To ensure accurate alignment of the cover and body, it is recommended the lower part of the cover's gasket seal is located into the body first. The top part of the seal can then be easily aligned.
16. Refit the cover bolts ensuring they are sequentially tightened in opposing pairs, gradually increasing torque to $63 \pm 5 \text{ N m}$ ($46.5 \pm 4 \text{ lbf ft}$).

Bolt size
M12 x 45

Socket size
19 mm A/F

Tightening torque
 $63 \pm 5 \text{ N m}$ ($46.5 \pm 4 \text{ lbf ft}$)

17. Carefully reconnect the motive steam supply and the exhaust lines to the connections marked (S) and (E). The APT14, APT14HC or APT14SHC is now ready to recommission.
18. Make sure that the Spirax Sarco motive supply strainer (with 100 mesh screen) is reinstated to the motive supply connection (item 28).

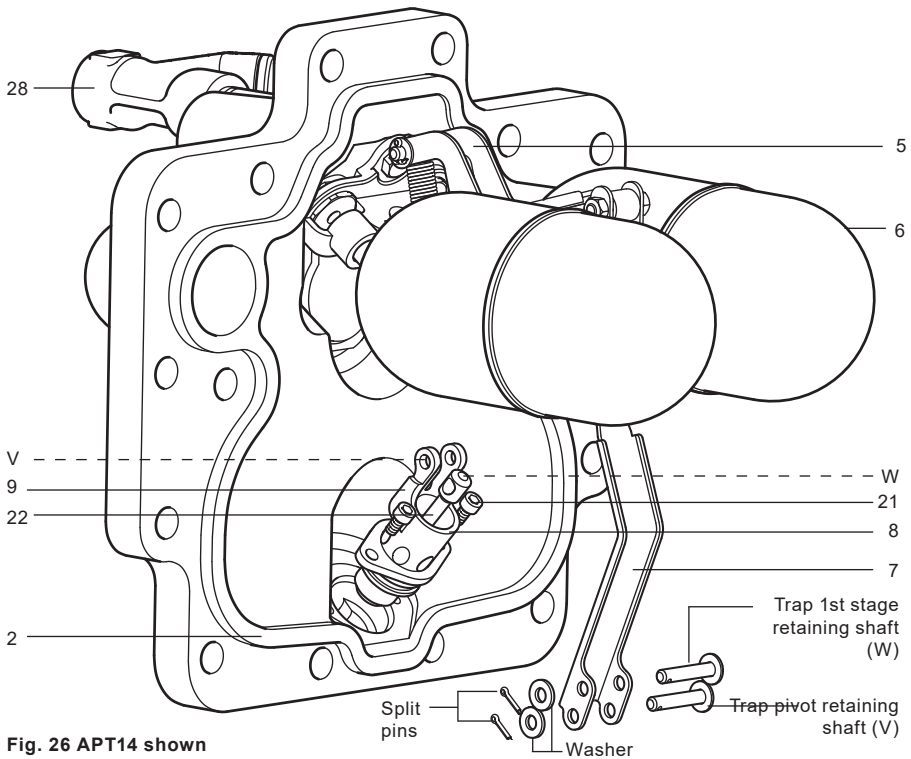

Fig. 26 APT14 shown

APT14, APT14HC and APT14SHC Automatic Pump Traps

8.2 Replacement of steam inlet/exhaust valves and seats

Please ensure the safety recommendations are observed before commencing with any maintenance of this product.

To replace the steam inlet and exhaust valve and seats

1. Remove the cover and old gasket (see cover gasket replacement procedure Section 7.1).
2. Lift the cover assembly to a bench or other convenient working surface and clamp securely, avoiding contact with the gasket face.
3. Carefully remove the circlip, washer and the inlet valve spring (item 27) from the end of the steam inlet valve (item 17).
4. Remove the three M8 bolts (items 20) using the 13 mm A/F socket.
5. Lift away the pump bracket assembly as this will allow access to the valve seats.
6. Using the 24 mm socket unscrew both the steam inlet and exhaust seats.
7. The seats, metal gaskets and steam inlet valve can now be removed.
8. Carefully clean the threads and gasket faces within the cover assembly ensuring all residues are removed.
9. Insert the replacement steam valve assembly (item 16 and item 17) according to Figure 27.

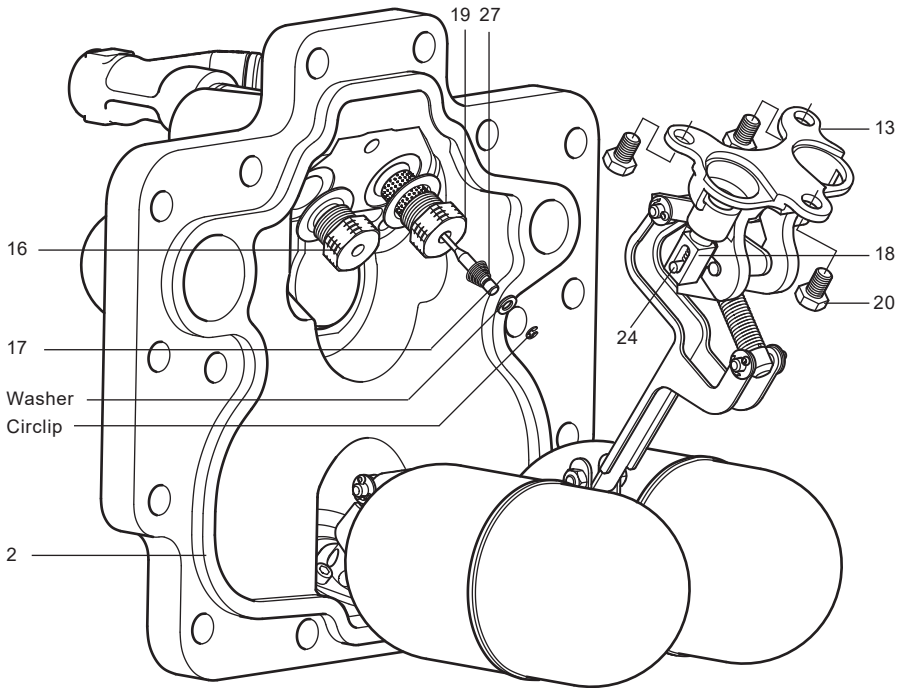

Fig. 27 APT14 shown

10. Place a new metal gasket (item 19) onto the threads of the seat before tightening into the cover.
11. Tighten the seat using the 24 mm socket to $125 \pm 7 \text{ N m}$ ($92 \pm 5 \text{ lbf ft}$).
12. The exhaust seat can be replaced in a similar way.
13. Refit the bracket to the cover and tighten the three M8 bolts using the 13 mm A/F socket to $18 \pm 2 \text{ N m}$ ($13 \pm 1.5 \text{ lbf ft}$).
14. It is important to ensure a new circlip is fitted to the steam inlet valve after the bracket has been bolted in place.
15. To remove the exhaust valve (item 18), remove split pins, washers, and shafts (X and Y) from the top spring pivot point and pump pivot point (See Figure 28).
16. Remove the spring and anchor assembly.
17. Draw the actuator arm with the exhaust valve downwards within its slots until it becomes free. It may be necessary to slide the exhaust valve backwards against its internal spring to free it from the pump bracket guide (item 13).
18. Remove the exhaust valve from the actuator arm.
19. **Fitting the replacement exhaust valve is the opposite to removal**, remembering to compress the small spring within the new valve before refitting to the spigot of the actuator arm.

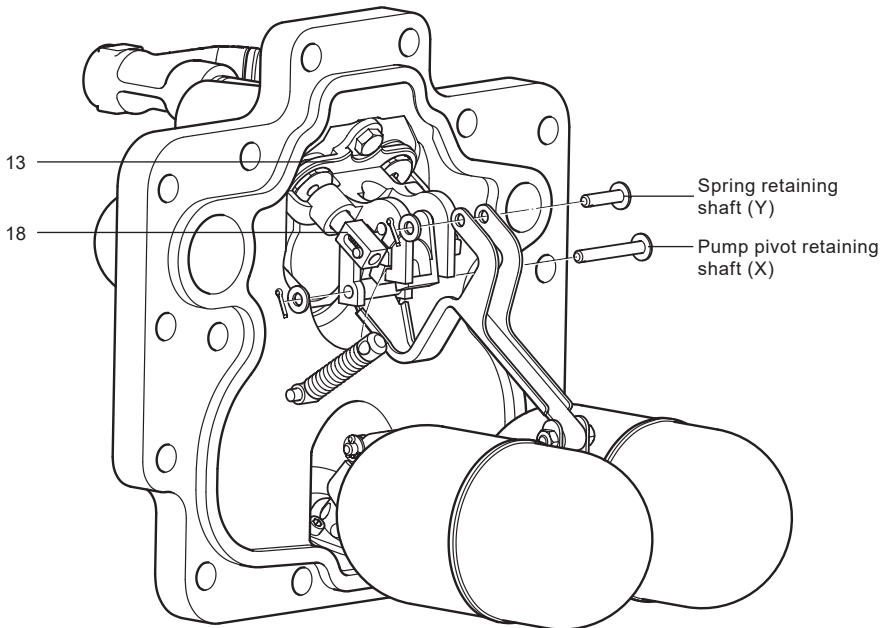

Fig. 28 APT14 shown

20. Ensure the actuator is correctly aligned and located within the slots of the pump bracket (item 13).
21. Once this is correctly located, ensure the exhaust valve can slide easily within its guides.
22. When refitting the spring retaining shaft (Y) (30 mm long) and pump pivot retaining shaft (X) (52 mm long), always use new split pins and washers.
23. Check that the mechanism snaps over and opens and closes the valves by moving the floats to their upper and lower limits of travel.
Note: The valve gear has been designed to be adjustment-free, simplifying the fitting of new parts. If after assembly the mechanism does not operate correctly, check all the parts are assembled and aligned as per Figure 28.
24. With the mechanism fully assembled, refit the cover assembly to the body, ensuring the gasket faces are carefully aligned and no parts of the gasket are trapped or pinched outside the sealing areas. To ensure accurate alignment of the cover and body, it is recommended the lower part of the cover's gasket seal is located into the body first. The top part of the seal can then be easily aligned.
25. Refit the cover bolts ensuring they are sequentially tightened in opposing pairs, gradually increasing torque to $63 \pm 5 \text{ N m}$ ($46.5 \pm 4 \text{ lbf ft}$).
26. Carefully reconnect the motive steam supply and the exhaust lines to the connections marked (S) and (E). The APT14, APT14HC or APT14SHC is now ready for recommission.
27. Make sure that the Spirax Sarco motive supply strainer (with 100 mesh screen) is reinstated to the motive supply connection (item 28).

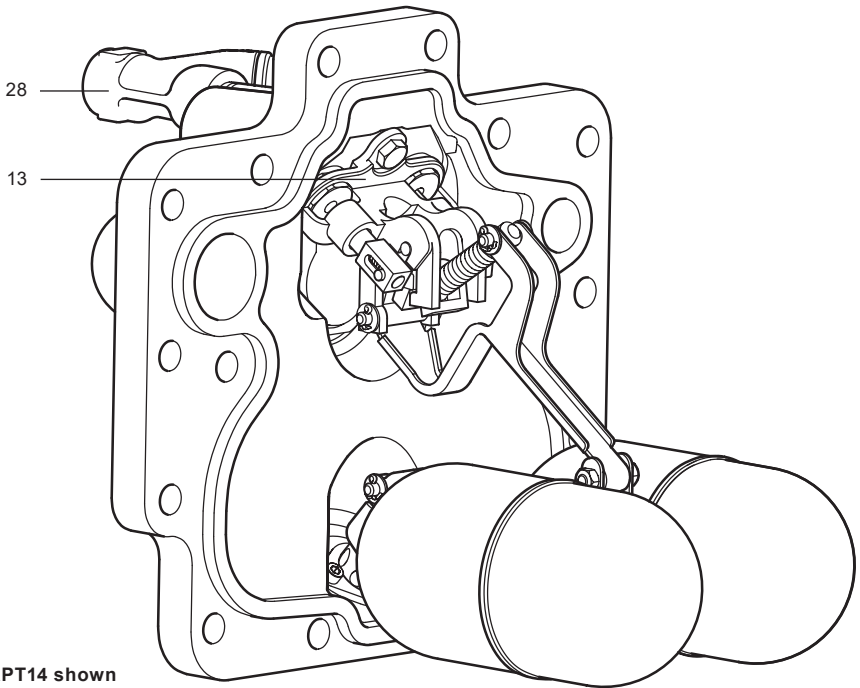

Fig. 28 APT14 shown

9. Fault finding guide

Caution

Installation and trouble shooting should only be performed by qualified personnel. Please read Section 1.12 regarding the safe lifting of this product before actioning any installation or maintenance procedure.

Before any maintenance is attempted, ensure any residual internal pressure in the product or connecting lines is carefully relieved. Also ensure any hot parts have cooled to prevent risk of injury from burns. Always wear appropriate safety clothing before carrying out any installation or maintenance work.

When dismantling this product, care should be taken to prevent injury from the snap action mechanism. Always handle with care.

The APT14, APT14HC and APT14SHC are thoroughly tested before leaving the factory. This includes a comprehensive functional test. If the unit has failed to operate it is likely that an installation problem could exist. Please check the following before commencing with the trouble-shooting chart.

9.1 Trouble areas to check first:-

- Are all isolating valves open?
- Is the condensate inlet strainer (as recommended in Figure 11, page 21) clean and free from debris?
- Is the motive supply strainer clean and free of debris?
- Does the installation head available exceed 0.2 m (8") from the base of the pump?
- Is the available motive pressure higher than the total backpressure? (recommended 3 to 4 bar g (44 to 58 psi g) but not exceeding 13.8 bar g (200 psi g))
- Is the exhaust balance line (E) connected to the outlet of the equipment being drained and is it free from obstruction (refer to installation diagram Figure 11, page 21)?
- Is the direction of flow through the unit correct, indicated by the flow arrow?

9.2 Quick reference trouble-shooting guide

SYMPTOM		APT fails to operate on start-up.
CAUSE 1		No motive pressure.
CHECK and CURE (1)		Motive supply pressure exceeds total backpressure.
CHECK and CURE (2)		Check supply is not isolated by manual or fail safe valve. Check reason for fail safe valve closure. Ensure reason resolved and reset valve to open position.
CAUSE 2		Inlet isolation valve maybe closed.
CHECK and CURE		Inlet pipe is free from obstructions and the isolation valve is open.
CAUSE 3		Motive inlet and exhaust lines incorrectly connected.
CHECK and CURE		Motive = S, Exhaust = E.
CAUSE 4		The rate of condensate produced by the process maybe very low, causing the APT to cycle slowly.
CHECK and CURE		The process being drained is operating correctly.
SYMPTOM		Equipment flooded - but APT appears to cycle normally.
CAUSE 1		APT is undersized for the application.
CHECK and CURE		Check system parameters agree with the custom sizing sheet/graph.
SYMPTOM		Equipment flooded and APT has stopped cycling.
CAUSE 1		Blocked exhaust line.
CHECK and CURE		Balance line is free from obstruction and is not waterlogged. Refer to installation diagram Figure 10, page 16.
CAUSE 2		Blocked condensate inlet line.
CHECK and CURE		Inspect and clean the strainer mesh, check for blockages.
CAUSE 3		Blocked condensate outlet line.
CHECK and CURE		Inspect line for blockages.
CAUSE 4		Damaged mechanism.
CHECK and CURE		Mechanism operates as per Section 6. Replace malfunctioning part(s).
CAUSE 5		No motive steam available.
CHECK and CURE (1)		Steam supply to APT is available and at the correct pressure. Motive pressure must exceed total backpressure. Ensure motive supply strainer is clear of debris. Clean or replace if necessary.

SYMPTOM	Equipment flooded and APT has stopped cycling (continued)
CAUSE 5	Check supply is not isolated by manual or fail safe valve. Check reason for fail safe valve closure. Ensure reason resolved and reset valve to open position.
CHECK and CURE (2)	
CAUSE 6	Leaking motive inlet valve.
CHECK and CURE	If the APT body is hot (observe safety note), this indicates the APT's mechanism is stuck on the discharge cycle. Check mechanism for excessive friction as per Section 6. Check motive inlet valve and spring for correct operation - replace malfunctioning part as per Section 8.
CAUSE 7	Broken spring.
CHECK and CURE	If the APT body is cold, this indicates the APT's mechanism is stuck on the filling cycle. Check pump mechanism spring - replace malfunctioning part as per Section 7.
CAUSE 8	Blocked condensate inlet line.
CHECK and CURE	Inspect and clean the filter, check for blockages.
SYMPTOM	Chattering or banging of the APT during cold start-up.
CAUSE 1	Hydraulic pulsing of the inlet check valve.
CHECK and CURE	Reduce installation head to APT - install throttling valve on APT condensate inlet.
SYMPTOM	Chattering or banging in the return line after APT discharges.
CAUSE 1	Live steam entering discharge line.
CHECK and CURE	Ensure steam traps draining the motive supply line are discharging to a non-flooded condensate return and the condensate return is adequately sized.

