

# Type 25T Pilot Operated Temperature Regulator

## Safety Information

Safe operation of these products can only be guaranteed if they are properly installed, commissioned, used and maintained by qualified personnel (see Section 1.11) in compliance with the operating instructions. General installation and safety instructions for pipeline and plant construction, as well as the proper use of tools and safety equipment must also be complied with.

### 1.1 Intended use

Referring to the Installation and Maintenance Instructions, name-plate and Technical Information Sheet, check that the product is suitable for the intended use/application.

- i) The products have been specifically designed for use on steam, air or water/condensate. The products' use on other fluids may be possible but, if this is contemplated, Spirax Sarco should be contacted to confirm the suitability of the product for the application being considered.
- ii) Check material suitability, pressure and temperature and their maximum and minimum values. If the maximum operating limits of the product are lower than those of the system in which it is being fitted, or if malfunction of the product could result in a dangerous overpressure or overtemperature occurrence, ensure a safety device is included in the system to prevent such over-limits situations.
- iii) Determine the correct installation situation and direction of fluid flow.
- iv) Spirax Sarco products are not intended to withstand external stresses that may be induced by any system to which they are fitted. It is the responsibility of the installer to consider these stresses and take adequate precautions to minimise them.
- v) Remove protection covers from all connections and protective film from all name-plates, where appropriate, before installation on steam or other high temperature applications.

### 1.2 Access

Ensure safe access and if necessary a safe working platform (suitably guarded) before attempting to work on the product. Arrange suitable lifting gear if required.

### 1.3 Lighting

Ensure adequate lighting, particularly where detailed or intricate work is required.

### 1.4 Hazardous liquids or gases in the pipeline

Consider what is in the pipeline or what may have been in the pipeline at some previous time. Consider: flammable materials, substances hazardous to health, extremes of temperature.

### 1.5 Hazardous environment around the product

Consider: explosion risk areas, lack of oxygen (e.g. tanks, pits), dangerous gases, extremes of temperature, hot surfaces, fire

hazard (e.g. during welding), excessive noise, moving machinery.

### 1.6 The system

Consider the effect on the complete system of the work proposed. Will any proposed action (e.g. closing isolation valves, electrical isolation) put any other part of the system or any personnel at risk?

Dangers might include isolation of vents or protective devices or the rendering ineffective of controls or alarms. Ensure isolation valves are turned on and off in a gradual way to avoid system shocks.

### 1.7 Pressure systems

Ensure that any pressure is isolated and safely vented to atmospheric pressure. Consider double isolation (double block and bleed) and the locking or labelling of closed valves. Do not assume that the system has depressurised even when the pressure gauge indicates zero.

### 1.8 Temperature

Allow time for temperature to normalise after isolation to avoid danger of burns.

### 1.9 Tools and consumables

Before starting work ensure that you have suitable tools and/or consumables available. Use only genuine Spirax Sarco replacement parts.

### 1.10 Protective clothing

Consider whether you and/or others in the vicinity require any protective clothing to protect against the hazards of, for example, chemicals, high/low temperature, radiation, noise, falling objects, and dangers to eyes and face.

### 1.11 Permits to work

All work must be carried out or be supervised by a suitably competent person. Installation and operating personnel should be trained in the correct use of the product according to the Installation and Maintenance Instructions.

Where a formal 'permit to work' system is in force it must be complied with. Where there is no such system, it is recommended that a responsible person should know what work is going on and, where necessary, arrange to have an assistant whose primary responsibility is safety.

Post 'warning notices' if necessary.

### 1.12 Handling

Manual handling of large and/or heavy products may present a risk of injury. Lifting, pushing, pulling, carrying or supporting a load by bodily force can cause injury particularly to the back. You are advised to assess the risks taking into account the task, the individual, the load and the working environment and use the appropriate handling method depending on the circumstances of the work being done.

### 1.13 Residual hazards

In normal use the external surface of the product may be very hot. If used at the maximum permitted operating conditions the surface temperature of some products may reach temperatures in excess of 300°C (572°F).

Many products are not self-draining. Take due care when dismantling or removing the product from an installation (refer to 'Maintenance instructions').

### 1.14 Freezing

Provision must be made to protect products which are not self-draining against frost damage in environments where they may be exposed to temperatures below freezing point.

### 1.15 Disposal

Unless otherwise stated in the Installation and Maintenance Instructions, this product is recyclable and no ecological hazard is anticipated with its disposal providing due care is taken.

### 1.16 Returning products

Customers and stockists are reminded that under EC Health, Safety and Environment Law, when returning products to Spirax Sarco they must provide information on any hazards and the precautions to be taken due to contamination residues or mechanical damage which may present a health, safety or environmental risk. This information must be provided in writing including Health and Safety data sheets relating to any substances identified as hazardous or potentially hazardous.

### 1.17 Working safely with cast iron products on steam

Cast iron products are commonly found on steam and condensate systems. If installed correctly using good steam engineering practices, it is perfectly safe. However, because of its mechanical properties, it is less forgiving compared to other materials such as SG iron or carbon steel. The following are the good engineering practices required to prevent waterhammer and ensure safe working conditions on a steam system.

### Safe Handling

Cast Iron is a brittle material. If the product is dropped during installation and there is any risk of damage the product should not be used unless it is fully inspected and pressure tested by the manufacturer.

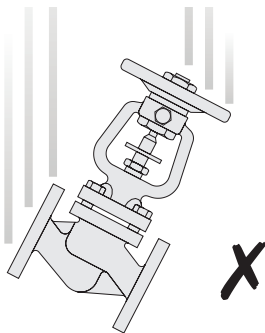

### Steam Mains - Do's and Don't's:

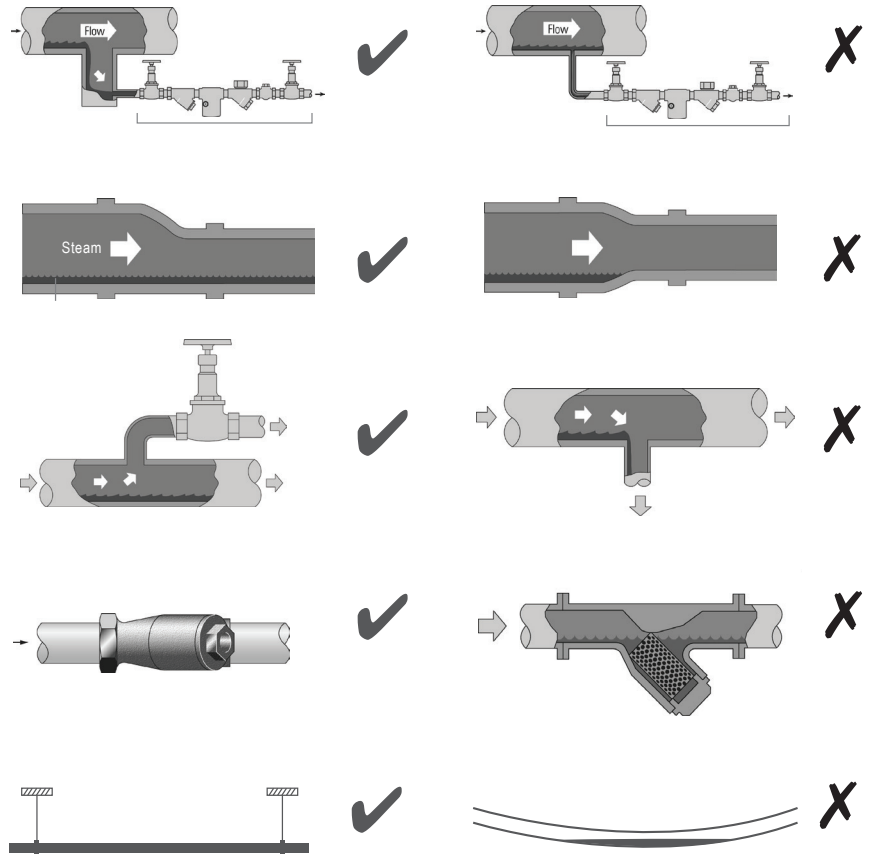

### Prevention of tensile stressing

Pipe misalignment:

Installing products or re-assembling after maintenance:



Do not over tighten.  
Use correct torque figures.

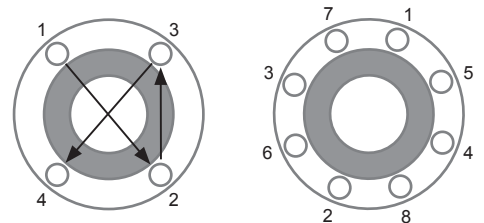

Flange bolts should be gradually tightened across diameters to ensure even load and alignment.

### Prevention of water hammer

Steam trapping on steam mains:

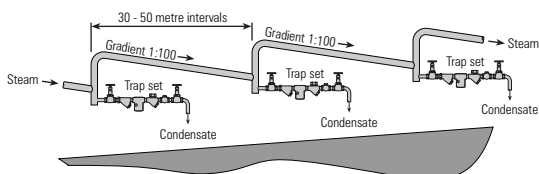

## Thermal expansion:

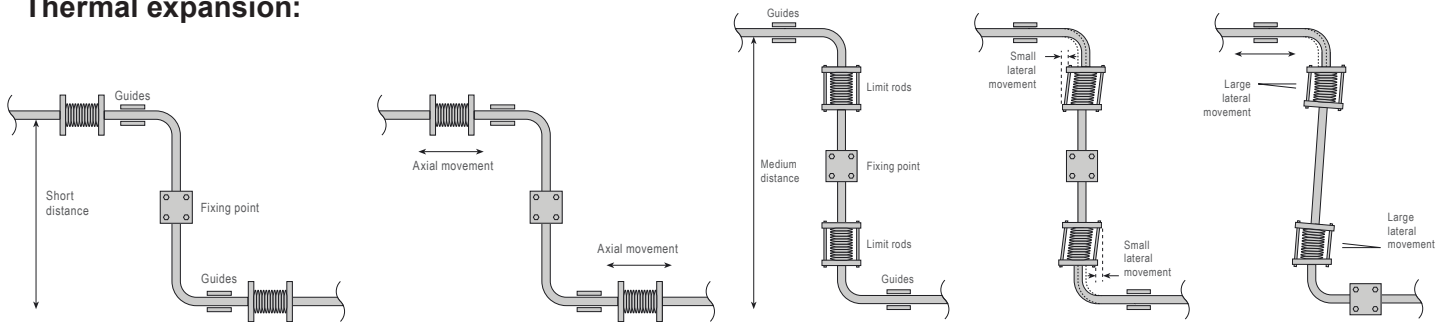

**IMPORTANT:** Step by step instructions on the following pages should be read carefully **before** installing the valve.

## Installing the Valve

### Unpack Carefully

Do not lift the regulator by the tubing or temperature pilot. Grasp the body of the valve firmly when lifting. Do not bend sharply or kink the flexible tubing.

### Piping

1. Typical hookup sketches as shown in Figs. 1 and 2 will aid in planning a correct installation.
2. Before installing the valve, make sure the piping is free of foreign material, scale, etc.
3. Make certain the arrow cast on regulator valve body is pointing in the direction of flow.
4. Regulating valve should always be installed in a horizontal position. (See Figs. 1 and 2.)

### Bypass

1. A bypass connection, as shown in Figs. 1 and 2, is recommended so that the valve can be serviced without shutting down the equipment.
2. The bypass valve should be the same size as the temperature regulating valve.

### Steam Line Drain Trap

To insure proper operation of the valve and avoid premature wear, it is recommended that a steam trap be installed on the steam supply line. (See Figs. 1 and 2.)

### Pipeline Strainers

1. It is strongly recommended that strainers be installed before the temperature regulating valve and steam traps. (See Figs. 1 and 2.)
2. Make certain adequate clearance is provided for screen removal and blowdown connection between strainer and regulating valve body.

### Stop Valves

All stop valves on the supply side, as well as on the downstream side of the temperature regulating valve, should be of the gate type so as to insure full rated capacity and good control.

### Calibrated Adjustment Dial

Depending upon the installation, the position of the calibrated dial on the valve, as received, may not be easily observed by the operating personnel. To change the calibrated dial position loosen hexagon nut (K) and rotate the entire adjustment assembly to a position that can be easily observed. Retighten hexagon nut (K).

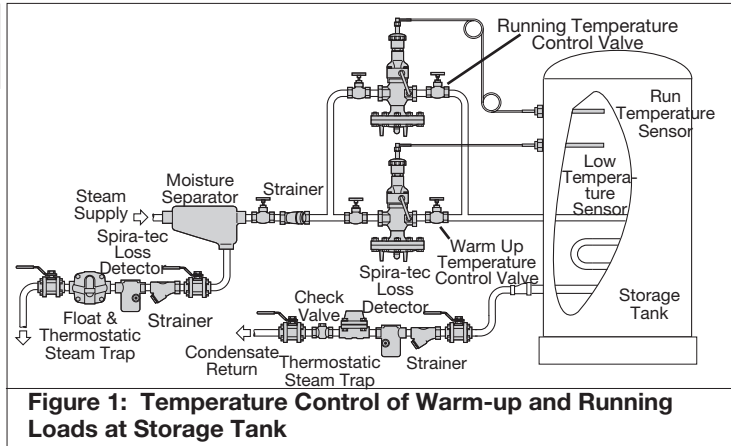

**Figure 1: Temperature Control of Warm-up and Running Loads at Storage Tank**

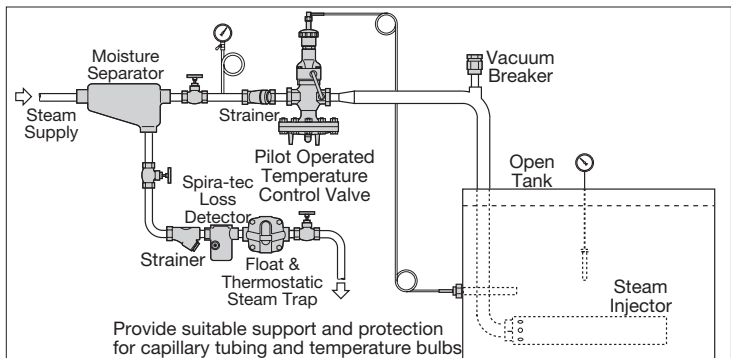

**Figure 2: Controlling Temperature of Large Open Tank Heated by Direct Steam Injection**

## Thermostatic Bulb and Tubing

1. Carefully uncoil the flexible tubing avoiding sharp bends and kinks.
2. Support flexible tubing to protect it against mechanical damage.
3. Keep flexible tubing away from hot pipe lines or other hot surfaces.
4. Install thermostatic bulb to unit to be controlled. Make certain that the entire bulb is exposed to the medium being controlled. Accuracy of regulation depends on the bulb being located in a representative location with adequate circulation over it.
5. If a separable socket is used for the temperature bulb, it is recommended that the socket be packed with a heat transfer compound to minimize lag in response to temperature changes caused by the insulating air layer between bulb and socket.

---

## Thermometer

An accurate thermometer should be installed in very close proximity to the temperature regulating bulb.

## How It Works

Normal positions before startup are with the main valve closed and the pilot valve held open by spring force. Entering steam passes through the pilot valve into the diaphragm chamber and also out through the control orifice. As flow through the pilot valve exceeds flow through the orifice, control pressure increases in the diaphragm chamber and opens the main valve. As the medium being heated approaches the pre-selected temperature, liquid in the bulb expands through the capillary tubing into the bellows and throttles the pilot valve (3E). Control pressure maintained in the diaphragm chamber positions the main valve to deliver required steam flow. When heat is not required, the main valve closes tight to provide dead-end shutoff. The temperature setting can be changed by turning the calibrated adjustment dial.

## Start-Up

1. First make certain that all stop valves are closed.
2. Adjust the temperature pilot to the temperature required by turning the red adjustment knob 3C. Caution: **Do not** loosen Allen set-screw in the red temperature knob.
3. Open stop valves in the following order:
  - a. Open stop valve ahead of steam trap on steam supply line. This will insure condensate free steam at the regulator inlet.
  - b. Open downstream stop valve.
  - c. Slowly open inlet stop valve.
4. After the system has stabilized itself, check thermometer temperature. Readjustment of the temperature pilot (red knob 3C) may be necessary. Note: In the event the temperature indicated on the calibrated dial does not agree with the thermometer, the temperature pilot can be recalibrated to match the thermometer as described on page 5.
5. Important—Retighten all pilot flange connections to insure steam tight joints.

## Maintenance

### General Inspection

While a program of planned maintenance is always to be recommended, the Spirax Sarco 25T temperature regulator will give long and trouble-free service if correctly selected, installed and kept reasonably free of dirt and foreign matter. Dirt and foreign matter are most likely to collect during installation and later trouble can be avoided by inspecting the installation a few days later. Check the following:

1. Clean all pipeline strainers (remove screens to clean).
2. Check the main valve seat and protective screen (1D).
3. Inspect and clean orifices (E) and (H).
4. Check all joints for leakage.

### Servicing Procedure (Refer to Fig. 3 and 4)

To determine which part of a malfunctioning temperature regulator requires maintenance, refer to the troubleshooting chart and follow this servicing procedure to check the tightness of the seats.

1. With all stop valves closed and the valve cooled down, remove the copper tubing from connectors (L)

and (N) for 1/2" - 2" valves, being careful not to bend them.

2. Close the pilot valve (K) by turning the temperature adjustment (3C) counter-clockwise until the spring is completely compressed.
3. Stand clear of the tubing connectors and open the inlet stop valve slightly so that a small amount of steam reaches the valve inlet and pilot.
4. Open and close the pilot valve a few times by turning the temperature adjustment and observe the steam flow from tubing connectors (N) for 1/2" - 2" valves. When the pilot valve is closed, there should be no steam flow from the connectors; if there is some steam flow, it indicates that the pilot valve assembly is faulty and must be replaced.
5. With the copper tubing removed the main valve head and seat are held closed and should not pass any steam. Observe the downstream orifice connector (L). Steam flow from this connector indicates that the main valve head and seat are leaking and require servicing.

### Inspecting and Replacing Pilot Valve Head and Seat. (Refer to Figs. 3 and 4)

NOTE: Inspecting and replacing parts, if necessary, can be done without removing the pilot from the main valve. However, if more convenient, the entire pilot can be removed from the main valve by removing the four pilot flange cap screws.

Exception: To replace the seat in low pressure (5 psi and below) 2-1/2", 3", and 4" valves, the entire pilot must be removed from the main valve or mounting bracket.

1. Unscrew hexagon nut (K) and remove temperature adjustment assembly.
2. The pilot valve head assembly (3E), which includes the springs, Teflon seal, and valve head, can then be withdrawn and inspected.
3. If it is found after inspection that the head is worn, the entire assembly should be replaced.
4. The pilot valve seat can be removed for inspection using a 1/2" hexagon socket wrench.
5. If the seat shows signs of wear, the seat should be replaced including a new seat gasket.

### Valve Sizes 1/2" Thru 4"

#### Inspecting and Replacing Main Valve Head and Seat. (Refer to Figs. 3 and 4)

1. Unscrew copper tubing connection at (J) and (N).
2. Remove main valve cover cap screws (1A).
3. Remove main valve cover, strainer screen, and head spring.
4. Head can then be removed by simply withdrawing with a pliers or similar tool.
5. Inspection should then be made to determine if scale or other foreign material prevented tight closure of the head and seat. Check for body erosion at the seat threads.
6. If it is necessary to replace the valve seat, this can be removed from the valve body using a standard hexagon socket. (Valve sizes 1/2" to 2".) When replacing the valve seat, a new gasket should be used to insure a tight joint. 2-1/2" valves contain raised lugs for removal and seal metal-to-metal without a gasket. Replacement heads and seats should be lapped in.

## Valve Sizes 1/2" Thru 4"

### Inspecting and Replacing Main Valve Diaphragms. (Refer to Figs. 3 and 4)

1. Unscrew copper tubing connection (G).
2. Remove main valve diaphragm bolts (1C).
3. This will allow the lower diaphragm case to be removed.
4. The 2 metal diaphragms (1H) should be inspected to insure that they have not become distorted or possibly fractured as a result of abnormal operating conditions.
5. At the same time any accumulation of dirt or foreign material should be removed from the diaphragm case.
6. The valve stem (1F) should also be checked to make sure it is free to move and that there is no scale or foreign material lodged in the guide bushing.
7. **Before reassembling diaphragms, main valve head must be in place and held in closed position with the return spring and main valve cover.**
8. Make certain pressure plate (1G) is set properly. (Refer to Fig. 5)
9. Care should be taken in centering the diaphragms properly and equalizing bolt take-up uniformly.

Size	1/2" & 3/4"	1"	1-1/4" & 1-1/2"	2"	2-1/2"	3"	4"
Dim A	1/16"	5/64	3/32"	1/8"	13/64"	13/64"	1/4"

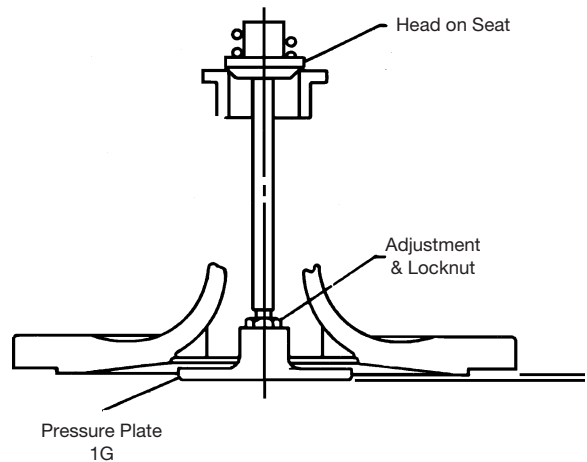

**Figure 5**  
**NOTE: IN 1/2" thru 4" sizes, top of valve must be completely assembled and head must be on seat when measuring dimensions "A" and when reassembling diaphragms.**

# Troubleshooting

## Type 25T

Symptom	Cause	Check and Cure	
1. Controlled temperature overrides set point.	1. (a) Control not set properly; or may have been tampered with.	1. (a) Readjust temperature knob (3C).	
	(B) Temperature bulb not in representative location .	(b) Check actual temperature at bulb with glass thermometer. If necessary, relocate bulb.	
	(c) Dirt under pilot valve head or pilot valve spindle (3E) sticking.	(c) Remove and, if necessary, replace or clean.	
	(d) Valve oversized.	(d) Check actual load against valve rating.	
	(e) Dirt in orifices (E) or (H).	(e) Inspect and clean.	
	(f) Dirt or foreign material under main valve head (1E). Seat worn, body casting eroded at seat threads.	(f) Set temperature knob (3C) to lowest temperature. Disconnect tubing at (G). Valve should close. If not, remove bolts (1A) and clean or repair main valve.	
	(g) Defective thermal system. (Rare).	(g) Experience over the years has shown that failure of the thermal system (other than mechanical damage) is very rare. Only after all of the “checks” listed on the troubleshooting chart have been pursued, should the following test be made to determine if the thermal system is defective. <ul style="list-style-type: none"> <li>i. Disconnect copper tubing connection at (J).</li> <li>ii. Immerse thermal system bulb in a temperature 20° above dial setting. Allow to saturate for approximately 5 minutes.</li> <li>iii. Open steam supply stop valve to allow steam to flow to temperature regulator.</li> <li>iv. Under these conditions steam should not flow from copper tubing connections (J) which shows that the thermal system is satisfactory.</li> <li>v. If steam should flow from tubing connection (J), exert pressure downward with thumb on thermal system elbow connection (3A). If this pressure seats pilot valve head and stops steam flow, the thermal system is probably defective.</li> </ul>	
	(h) Bypass valve leaking.	(h) Check and correct.	
	2. Temperature too low or valve does not open.	2. (a) Control not properly set or may have been tampered with.	2. (a) Adjust temperature knob (3C) to higher setting.
		(b) Thermostatic bulb not in representative location.	(b) Check actual temperature at bulb with glass thermometer. If necessary, relocate bulb.
(c) Valve undersized.		(c) Check actual load against rating of valve.	
(d) Main valve diaphragm (1H) cracked.		(d) Remove copper tubing at (G) and crack bypass valve. If steam blows from diaphragm case at (G) connection, replace diaphragm.	
(e) Orifice at (H) blocked.		(e) Remove copper tubing at fitting. Inspect and clean.	
(f) Steam pressure too low.		(f) Check and correct.	
(g) Valve strainer (1D) blocked.		(g) Remove bolts (1A). Inspect strainer and clean.	
(h) Line strainer partially or completely blocked.		(h) Inspect and clean.	
(i) Pilot valve spindle (3E) sticking in guide.		(i) Remove thermal system by loosening nut (M). Apply pressure to spindle, observe up and down motion. If necessary, clean or replace spindle assembly.	
(j) Steam trap draining equipment may not be functioning properly.		(j) Check and repair, if necessary.	
3. Erratic control.	3. (a) Thermostatic bulb is not installed in the proper location.	3. (a) Check actual temperature at bulb with glass thermometer. Relocate bulb, if necessary.	
	(b) Heating surface may be waterlogged due to defective steam trap.	(b) Inspect and repair, if necessary.	
	(c) Valve size may not be correct.	(c) Check actual load against valve rating.	

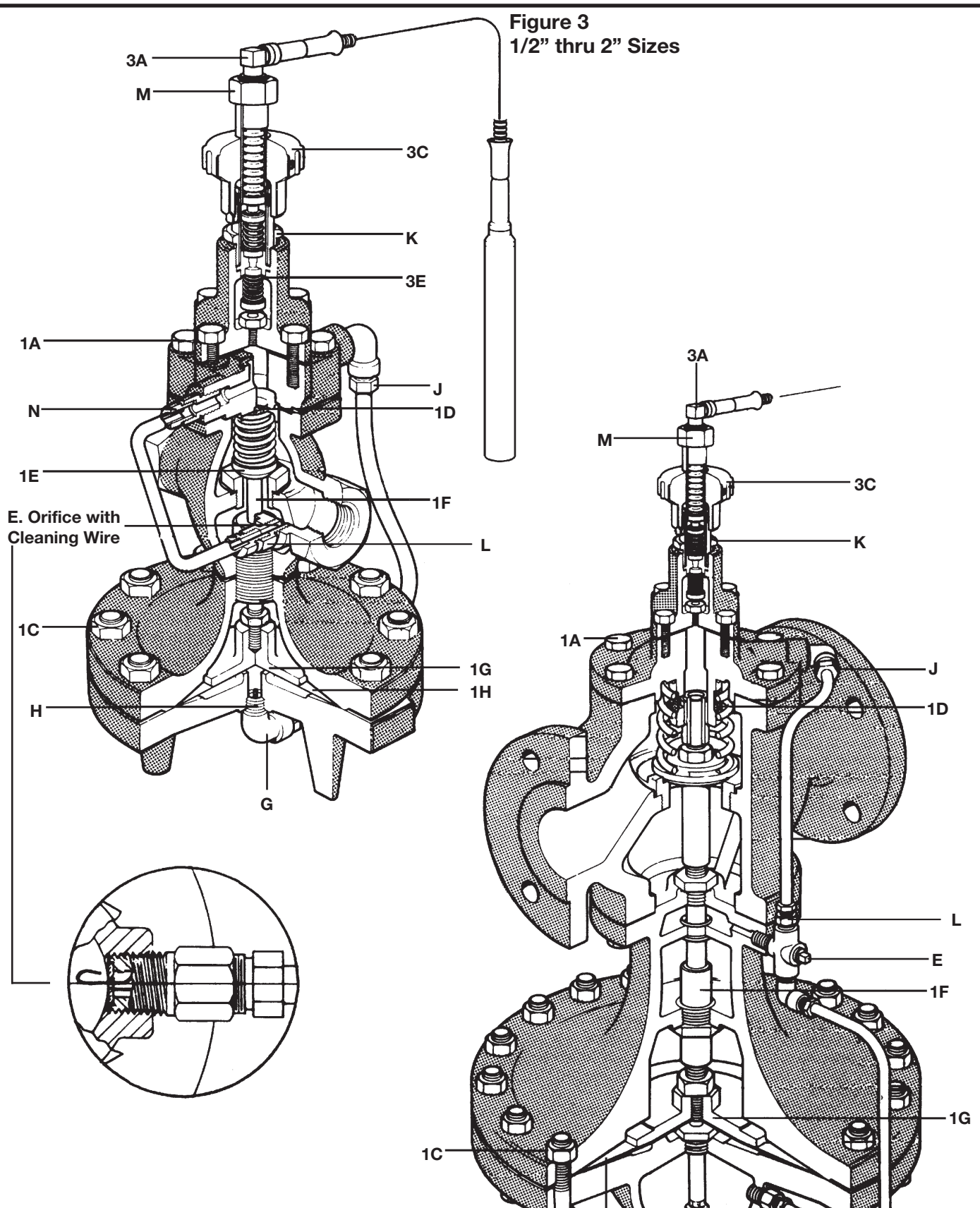

Figure 3  
1/2" thru 2" Sizes

Figure 4  
2-1/2" thru 4" Sizes

---

Spirax Sarco Applications Engineering Department

**Toll Free at:**  
**1-800-575-0394**

**spirax**  
**/sarco**

SPIRAX SARCO, INC. • 1150 NORTHPOINT BLVD. • BLYTHEWOOD, SC 29016  
PHONE 803-714-2000 • FAX 803-714-2200