

TYPE E2 MAIN VALVE

TYPE E2 MAIN VALVE

LOW PRESSURE LOW DIFFERENTIAL

SIZES 3/4" – 10"
PRESSURES to 15 PSIG at 250°F

- Normally Closed
- Single Seat
- Nitrile Diaphragm
- Protected Main Spring
- Gas & Steam Applications
- Accurate Regulation Unaffected by Service Conditions
- ANSI/FCI 70-2 Class IV Shutoff
- Virtually Frictionless for Long Service Life
- Packless Construction
- Easy In-line Maintenance
- Wide Variety of Pilots for Many Applications
- Minimum Operating ΔP 3 psi (.2 bar)
- Lifetime Warranty against Wiredrawing of Seat & Disc *

APPLICATION DATA

- Pressure Regulating for Steam Distribution
- Regulating for Process Control (Temperature or Pressure)
- Maintain Back Pressure or Differential Pressure
- For use with Self-contained, Pneumatic or Electronic Pilots
- Single Point or Multiple Use Applications
- Slow Start-up or Shutdown

VALVE RATINGS

Valve Ends ASME/ANSI	Pressure PSIG (bar)	Temperature °F (°C)
CAST IRON		
B16.4 Class 250 NPT	15 (1.03)	250°F (121°C)
B16.1 Class 125 Flanged	15 (1.03)	250°F (121°C)

Canadian Registration # OC 0591.9C

Installation Tip: Add EZ Connections for ease of maintenance
SEE PAGE 40

SIZING INFO
PAGE 106

OPTIONS

- Composition Disc for liquid, air or gas service
- Insulcap Insulating Jacket
- Integral Mount Pilot
- EZ Connections

TYPICAL CONFIGURATIONS

- PRESSURE REDUCINGTYPE E2D
- AIR ADJUSTEDTYPE E2A SERIES
- BACK PRESSURETYPE E2Q
- LOAD ALLOCATINGTYPE E2FD
- AIR CONTROLLEDTYPE E2AP60
- ELECTRONIC SLOW STARTTYPE E2D208D
- SOLENOID CONTROLLEDTYPE E2MD
- SOLENOID ACTUATEDTYPE E2M
- DIFFERENTIAL.....TYPE E2N
- TEMPERATURE CONTROLTYPE E2T14
- TEMP. & PRESSURE CONTROLTYPE E2T134

RATED FLOW COEFFICIENTS (Cv)

SEAT FACTOR	REGULATOR SIZE												
	3/4	1	1 1/4	1 1/2	2	2 1/2	3	4	5	6	8	10	12
Full	7.6	11.7	18.9	27.4	44	68	96	143	202	255	465	748	1118
70%-75%	—	8.8	13.2	19.2	30.8	47.6	67.2	100	141	178	—	—	—
45%	—	—	—	12.3	—	30.6	—	64.4	—	115	—	336	—

* When installed according to factory specifications.

TYPE E2 MAIN VALVE

SPECIFICATION

The valve shall be self-operated, external pilot type, single seated, nitrile diaphragm actuated, normally closed design. The valve will function quickly and shut tight on dead end service. Internal parts including seats, discs and stems shall be of stainless steel. There shall be no springs in the steam flow path and no stuffing box. The valve shall be easy to maintain with all parts accessible without removal from the line.

MATERIALS OF CONSTRUCTION

Body, Cast IronASTM A126 Cl. B
 Stem303 St. Stl. ASTM A582
 Disc 3/4 - 2"420 St. Stl. ASTM A743 CA-40
 Disc 2-1/2 - 10"304 St. Stl. ASTM A167/A240
 Seat420 St. Stl. ASTM A743 CA-40
 GasketNon-asbestos
 DiaphragmNitrile
 SpringSteel

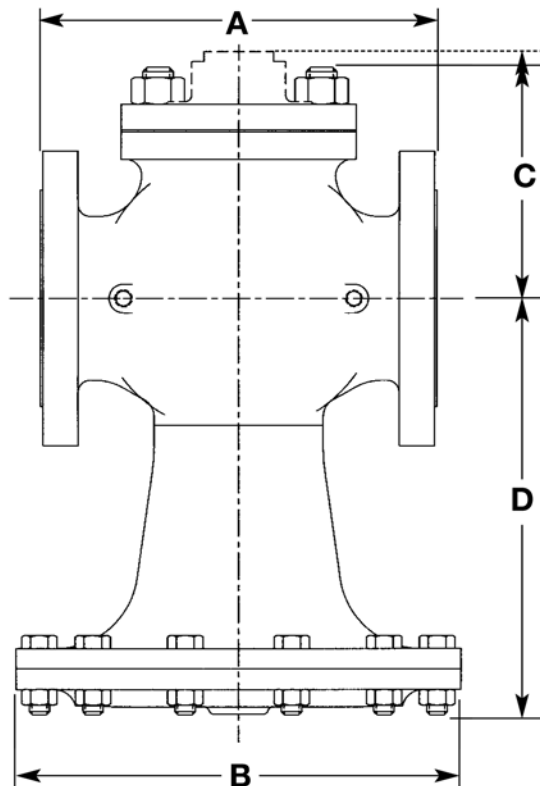

TYPE E2
MAIN VALVE

TYPE E2 MAIN VALVE

FITTINGS ON
PAGE 44

DIMENSIONS inches (mm), **WEIGHTS** pounds (kg)

SIZE	A		OTHER DIMENSIONS				APPROX. WT.	
	Cl, ANSI NPT	Cl ANSI 125	B	C		D*	Cl, ANSI NPT	Cl ANSI 125
				Std. Mount	Integral Mount			
3/4 (19)	4 3/4 (121)	—	8 (203)	2 7/8 (73)	3 5/8 (92)	7 3/4 (197)	18 (8)	—
1 (25)	5 3/8 (137)	5 1/2 (140)	8 (203)	3 3/8 (92)	4 3/8 (111)	8 1/8 (206)	19 (9)	21 (10)
1 1/4 (32)	6 1/2 (165)	6 3/4 (171)	9 (229)	4 1/8 (105)	4 (101)	8 1/4 (210)	30 (14)	33 (15)
1 1/2 (38)	7 1/4 (184)	6 7/8 (175)	9 3/4 (248)	4 3/8 (111)	4 1/2 (118)	8 3/4 (222)	36 (16)	40 (18)
2 (51)	7 1/2 (191)	8 1/2 (216)	10 1/2 (267)	5 1/4 (133)	5 (127)	10 (254)	50 (23)	57 (26)
2 1/2 (64)	—	9 3/8 (238)	10 1/2 (267)	5 3/4 (146)	5 3/8 (136)	11 1/2 (292)	—	70 (32)
3 (76)	—	10 (254)	11 1/4 (286)	6 3/8 (168)	6 3/8 (162)	12 3/4 (324)	—	98 (45)
4 (102)	—	11 7/8 (302)	13 1/2 (343)	6 3/4 (171)	6 5/8 (168)	13 3/8 (346)	—	135 (61)
5 (127)	—	13 3/8 (346)	14 1/4 (362)	7 1/2 (191)	7 3/8 (187)	15 (381)	—	185 (84)
6 (152)	—	15 1/8 (384)	16 (406)	7 7/8 (200)	7 (178)	16 5/8 (422)	—	250 (114)
8 (203)	—	19 (483)	20 (508)	9 1/2 (241)	9 1/4 (235)	19 7/8 (505)	—	1210 (550)
10 (254)	—	23 3/8 (600)	24 (610)	10 7/8 (276)	—	23 7/8 (606)	—	690 (314)

*Add 55% to D dimension for stem removal clearance.