

FLOAT VALVE NO. 7 FLOAT VALVE NO. 77

Single Seated, Dead End Service (tight closing)
Globe or Angle

BRONZE • CAST IRON • STAINLESS STEEL BODY

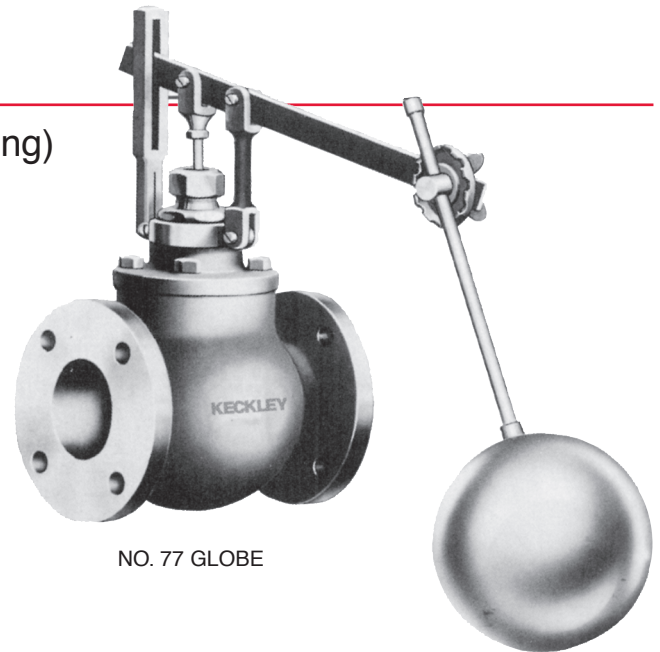

NO. 77 GLOBE

Application/Service: The No. 7 and 77 pilot controlled float valves are recommended when tight closing is essential. They are commonly used to maintain a water level in an open tank. They are best suited for clean liquids not injurious to neoprene, leather or brass parts. Standard design temperature is 125°F. For higher temperatures up to 350°F, the neoprene disc in the No. 7 or neoprene disc and leather cup in the No. 77 are replaced by teflon parts.

Construction: Referring to the sectional views on page 8, the inner valve consists of a hollow bronze piston, somewhat larger in diameter than the seat bore, and carrying the disc holder. The composition disc may be replaced when worn. The soft disc will accommodate itself to grit and wear and still close tight where a metal to metal construction would leak.

The piston slides in a stationary bronze cylinder attached to the cover or body. The pilot port is opened and closed by the end of the stem which is moved by the lever. A pin through the stem at its lower end permits the inner valve to be lifted by the stem.

The guide yoke, with the lever and float, can be turned and secured at any angle. The angle and length of float rod can be adjusted at the rosette.

Operation: In the No. 7 valve, made in sizes 2 inches and smaller, water from the inlet enters the space above the piston through a small hole in the piston head. While the pilot port is open, this water escapes freely through the hollow valve post to the outlet. The excess pressure under the piston, in relation to the pressure above it, and the weight of the float hold the valve open.

On closing the pilot port, the water pressure above the piston quickly rises to equal and balance the inlet pressure under the piston. Thereupon the inlet pressure above the disc holder closes the valve. No leather cup is required.

The disc closes in the direction of the flow through the No. 7 valve. In the larger valves and for the higher pressures, the "pull" of the water in passing through the valve seat may cause the valve to close suddenly from a nearly closed position. For

this reason, this valve is not made in sizes above 2 inches.

In the No. 77 valve, made in sizes 2 inches and larger, the inlet pressure is under the disc. Water enters the chamber above the piston through the strainer and the central and diagonal passages. If the pilot port is open, this water escapes freely to the valve outlet, so that the inlet pressure under the disc opens the valve. When the pilot port is closed, the water pressure above the piston quickly rises to equal the inlet pressure under the disc and, due to the larger piston area, the inner valve is moved toward the seat.

The disc closes against the inlet pressure and sudden closing cannot occur in the No. 77. However, this valve requires the piston to be fitted with a leather cup, the friction of which may cause sluggishness on low inlet pressures.

Maximum inlet pressures for both the No. 7 and No. 77 are shown in the table on the next page.

FLOAT VALVE NO. 7 FLOAT VALVE NO. 77

Internal Pilot Control, Single Seated,
Dead End Service, Globe or Angle
BRONZE • CAST IRON • STAINLESS STEEL BODY

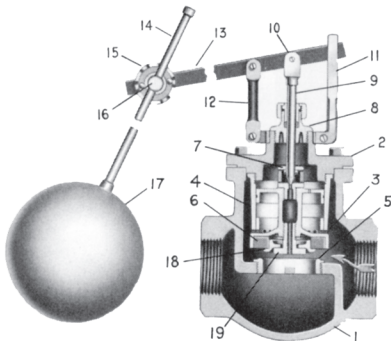

NO. 7 GLOBE

LIST OF PARTS

- 1 — Body
- 2 — Cover*
- 3 — Inner Valve
- 4 — Cylinder*
- 5 — Seat Bushing*
- 6 — Composition Valve Disc
- 7 — Port Stud*
- 8 — Packing Box
- 9 — Valve Stem
- 10 — Stem Clevis
- 11 — Swivel Guide Yoke
- 12 — Guide Arm
- 13 — Lever
- 14 — Float Rod
- 15 — Rosette
- 16 — Float Rod Bolt
- 17 — Float
- 18 — Disc Plate
- 19 — Disc Plate Screw*
- +20 — Strainer*
- +21 — Leather Cup*
- +22 — Lock Nut*

*Parts used only in sizes 2" and larger.
+ Used in No. 77 only.

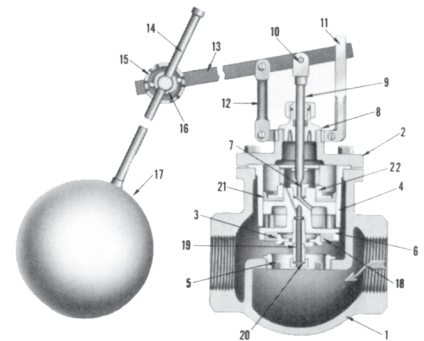

NO. 77 GLOBE

Materials: No. 7 valves in sizes 1½ inch and smaller have bronze bodies and integral seats, screwed ends only. The 2 inch No. 7 and all sizes of the No. 77 have cast iron bodies, with renewable seats, screwed or flanged ends in sizes 2 inch to 3 inch inclusive, flanged ends only above 3 inch. All sizes of both valves have bronze trim and renewable composition discs.

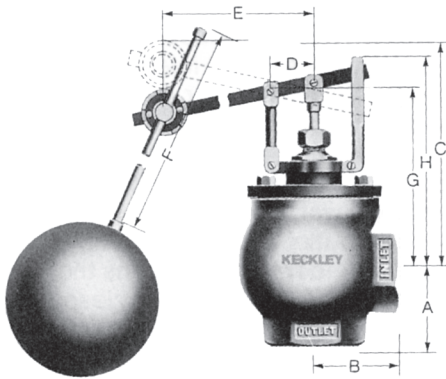

NO. 7 ANGLE
(SIDE INLET)

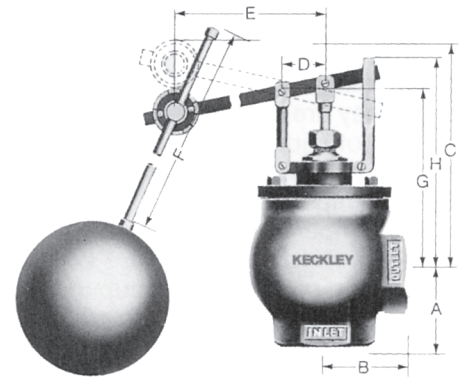

NO. 77 ANGLE
(BOTTOM INLET)

NOS. 7 and 77—DIMENSIONS—WEIGHTS (approximate)

Size Inches	A or B—Inches Angle Pattern			Face to Face—Inches Globe Pattern			Angle Pattern— Inches						Float Diam- eter Inches	Shipping Weight-Lbs. Globe Pattern			Capacity Factor Page 11	Max.** Inlet Pressure	
	Std. Scr.	Std. Flg.	Ex. Hvy. Flg.	Std. Scr.	Std. Flg.	Ex. Hvy. Flg.	C	D	E	F	G	H		Std. Scr.	Std. Flg.	Ex. Hvy. Flg.			
NO. 7	½ & ¾	2	—	—	4½	—	—	8⅞	1⅝	13⅜	16	5⅞	6⅞	7	11	—	—	.17	130
	1	2¼	—	—	5	—	—	8¾	1⅝	13⅜	16	5½	6¾	7	13	—	—	.35	100
	1¼	2½	—	—	5½	—	—	8¾	1⅝	13⅜	16	5½	6¾	7	14	—	—	.50	80
	1½	2½	—	—	5½	—	—	9	1⅝	13⅜	16	5½	6¾	7	14	—	—	.80	65
	2	3¼	4½	4¾	7⅞	8¼	8¾	12¾	1⅝	17¾	16	8	10½	7	35	45	60	1.6	50
NO. 77	2	3¼	4½	4¾	7⅞	8¼	8¾	12¾	1⅝	17¾	16	8	10½	7	35	45	60	1.6	250
	2½	3⅝	4¾	5⅞	8¾	9½	10½	12¾	1⅝	17¾	18	8½	10½	8	55	68	72	2.5	250
	3	4½	5¾	5¾	9¾	10½	11¼	13¾	1⅝	17¾	18	9½	11¼	8	71	80	115	3.5	250
	4	—	6¾	6¾	—	12¼	12¾	13¾	1⅝	17¾	18	9¾	11½	8	—	140	145	6.5	250
	5	—	7¼	7⅞	—	14½	15¾	18½	2½	20½	24	11¼	14¼	10	—	235	195	10.0	250
	6	—	8¾	8¾	—	16¼	17¾	19¾	2½	20½	24	12½	15½	10	—	235	240	14.0	250
8	—	9¾	9¾	—	19¾	20½	25	3	28	30	16¼	21	10	—	395	445	26.0	250	
10	globe pattern only			—	—	20½	21½	36	5	41	30	29	35	12	—	650	700	41.0	250

**The absolute minimum operating pressure for the #77 Float Valve is 5 psi for sizes 2" through 6" and 10 psi for sizes 8" and 10".

The neck of the globe body is slightly longer than the neck of the angle body. Therefore dimensions G, H, and C are slightly greater than those shown above. Certified Dimensional Sheets Available.