

DRAWING NO.
73146-AL

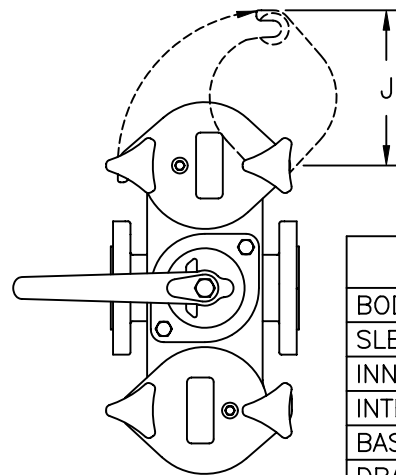
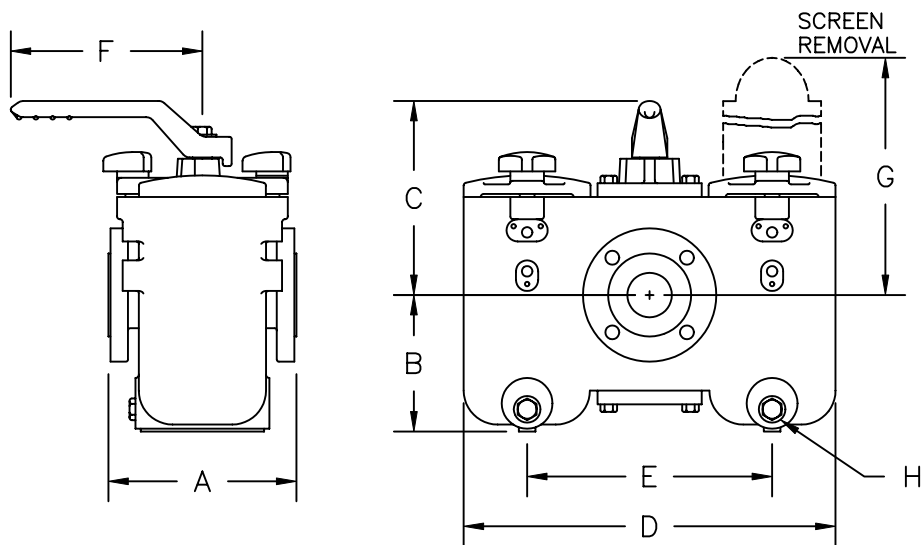

PARTS LIST	
BODY	CARBON STEEL
SLEEVE	BRONZE
INNER VALVES	BRONZE
INTERNAL MACHINE PARTS	STAINLESS STEEL
BASKETS	STAINLESS STEEL
DRAIN PLUGS	BRASS
O-RINGS	NITRILE
MAX. WORKING PRESSURE - 285PSI AT 100°F	

PIPE SIZE	A	B	C	D	E	F	G	H	J	WEIGHTS
1"	6	4-1/8	5-7/8	10-5/8	6-11/16	6-7/8	8-11/16	1/2	4-7/8	44
1-1/2"	6-7/8	5-3/4	6-7/8	11-3/16	7-1/4	6-7/8	12	1/2	4-7/8	53
2"	8-1/4	6-1/8	8-3/4	16-3/4	11	8-1/4	13-13/16	1/2	7	128
2-1/2"	8-1/4	6-1/8	8-3/4	16-3/4	11	8-1/4	13-13/16	1/2	7	132
3"	10-1/2	8-1/4	10-1/16	19-1/4	13	9-7/8	17-3/4	1/2	7-3/4	210
4"	12-1/2	10-7/16	11-9/16	21-1/4	15	9-7/8	22-5/8	1/2	7-3/4	300
5**	18-5/8	10-9/16	13	23-1/2	16	15	22-5/8	1/2	7-3/4	632
6**	18-5/8	10-9/16	13	23-1/2	16	15	22-5/8	1/2	7-3/4	642
8"	22	20-1/2	21-11/16	40-1/8	27-9/16	19-11/16	47-5/8	1/2	BOLTED COVER	1808

** 5" & 6" DUPLEX STRAINERS HAVE (2) BASKETS PER CHAMBER FOR A TOTAL OF (4) BASKETS

5", 6" & 8" SIZES HAVE STANDARD MOUNTING PADS AND PRESSURE EQUALIZING VALVES.

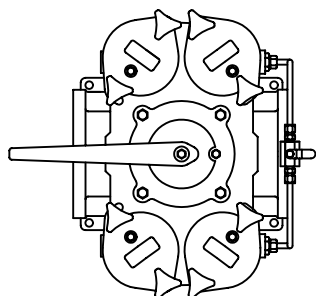

KECKLEY

3400 CLEVELAND SKOKIE ILLINOIS

STYLE SDPXF DUPLEX STRAINER

150# FLANGED CONNECTIONS

MAT'L: AS NOTED

REQ. —

DRAWING NO.
73146-AL

PART NO.

SCALE: NTS

DATE: 8/14/96

DR. BY REW