

Style D & DV

Basket Strainer

Cast Iron (ASTM A 126, Class B)

125 lb. & 250 lb. Flanged



Cast Iron Basket Strainer

APPLICATIONS

Steam, water, oil or gas where protection from foreign matter in a pipeline is required.

CONSTRUCTION

The Keckley Style D & DV strainers are constructed from rugged cast iron castings and are machined to exacting specifications. These bodies have drilled flanges that are in accordance with ASME B16.1.

FEATURES

The Keckley Style D & DV strainers feature a machined basket seat to minimize particle bypass. All sizes have a bolted top cover flange for ease in basket removal. The gasket is a synthetic fiber and is compressed between the body and cover for maximum strength and durability. All Keckley Style D & DV strainers are furnished standard with a tapped and plugged NPT drain connection.

BASKETS

Standard baskets are 304 stainless steel and are spot welded for maximum strength. Different size perforations and meshes are available in stainless steel, monel, and brass to meet specific media requirements. If media is not indicated, screens for *water* will be supplied.

CLEANING

Cleaning of the Style D strainer is accomplished by removing the cover and pulling out the basket. The Style DV basket has an open bottom and is cleaned by blowing trapped material out through the blow-off connection similar to a “Y” type strainer. **Warning:** See Maintenance Instructions on page S6 of the Strainer Information Section for additional precautions and detailed information on servicing the strainer.

WORKING PRESSURES – NON SHOCK

NOM. RATING	MEDIA	2" to 12"	50 mm to 300 mm
125# F.F. & D. (STANDARD FLANGE)	STEAM	125 PSI @ 450°F	862 KPa @ 232°C
	W.O.G.	200 PSI @ 150°F	1379 KPa @ 66°C
NOM. RATING	MEDIA	2" to 12"	50 mm to 300 mm
250# R.F. & D. (EX. HEAVY FLANGE)	STEAM	250 PSI @ 450°F	1724 KPa @ 232°C
	W.O.G.	500 PSI @ 150°F	3449 KPa @ 66°C

GOVERNMENT/MILITARY SPECIFICATIONS

Style D & DV cast iron flanged basket strainers meet or exceed government specification WW-S-2739 (Supersedes MIL-S-16293).

Style D & DV

Basket Strainer, 125 lb. & 250 lb. Flanged Cast Iron (ASTM A 126, Class B)

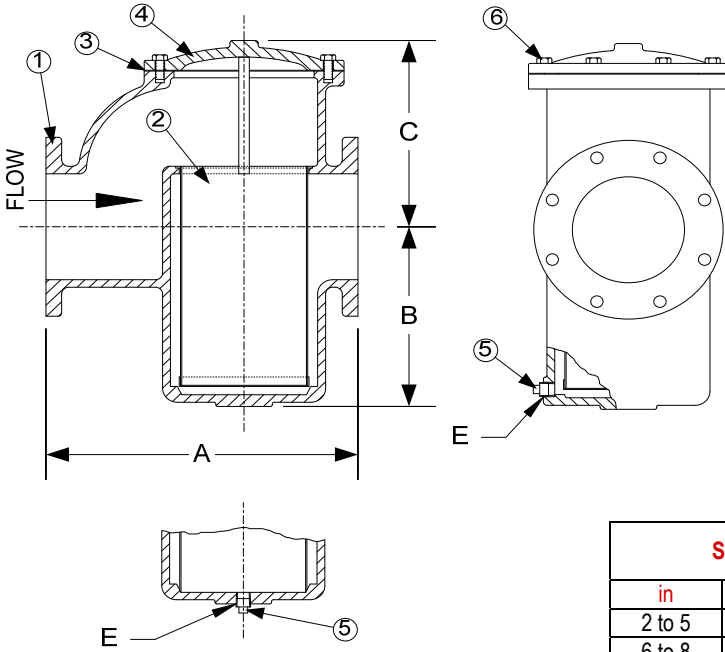

Style DV has a bottom blow off with an open bottom basket.

PARTS LIST

ITEM	DESCRIPTION	MATERIAL
1	BODY	CAST IRON (ASTM A 126, CLASS B)
2	BASKET	STAINLESS STEEL (304)
3	GASKET	COMPOSITION
4	COVER	CAST IRON (ASTM A 126, CLASS B)
5	PIPE PLUG	MALLEABLE IRON
6	HEX HEAD CAP BOLTS	STEEL

STANDARD SCREENS SUPPLIED

SIZE		SCREEN GAGE	SCREEN PERFORATION					
in	mm		FOR STEAM		OPEN AREA	FOR LIQUID		OPEN AREA
			in	mm		in	mm	
2 to 5	50 to 125	28	1/16	1.6	30%	1/8	3.2	43%
6 to 8	150 to 200	24	1/8	3.2	43%	1/8	3.2	43%
10 to 12	250 to 300	20	1/8	3.2	43%	1/8	3.2	43%

Standard screens supplied are for **liquid service**, unless otherwise specified.
Options: Other perforations, meshes, and screen material are available.

SIZE	DIMENSIONS											WEIGHTS			
			A		B		C		E						
	in	mm	125#	250#	125# & 250#	125# & 250#	125# & 250#	125# & 250#	125# & 250#	125#	250#	lbs	kgs	lbs	kgs
2	50	8	203	8-1/2	216	3-15/16	100	5-1/4	133	1/2	15	23	10	29	13
2-1/2	65	9	229	9-5/8	245	4	102	6	152	1/2	15	33	15	42	19
3	80	10	254	10-3/4	273	5	127	7	178	1/2	15	45	21	55	25
4	100	13-1/4	337	13-7/8	352	6-3/4	171	9-1/2	241	1/2	15	116	53	122	55
5	125	16-7/8	429	17-3/4	451	9-7/8	251	12	305	3/4	20	165	75	195	88
6	150	17	432	17-7/8	454	9-7/8	251	12	305	3/4	20	175	79	211	96
8	200	22-1/4	565	23-1/4	591	13-3/4	349	14	356	3/4	20	345	156	410	186
10	250	26	660	27-3/8	695	17	432	18	457	3/4	20	688	312	748	339
12	300	30-1/4	768	31-3/4	806	20-5/8	524	21	533	2	50	1135	515	1285	583

Consult factory for sizes not shown.
Certified dimensional drawings are available upon request.
† This table reflects only the nearest metric equivalents.

PRESSURE vs. TEMPERATURE CHART
125# & 250# Flanged Cast Iron (ASTM A 126, Class B)

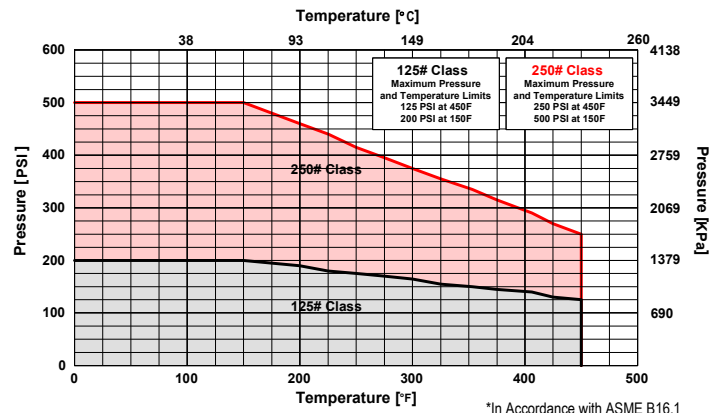

FLOW COEFFICIENTS

Size	C _v	Size	C _v	Size	C _v
2"	55.7	4"	208.7	8"	784.3
2-1/2"	88.5	5"	354.2	10"	1208
3"	123.3	6"	430.1	12"	1868.9

TOTAL SCREEN AREA

Size	(in ²)	Size	(in ²)	Size	(in ²)
2"	39.45	4"	152.58	8"	529.98
2-1/2"	51.66	5"	295.54	10"	808.58
3"	84.84	6"	295.54	12"	1252

*See DETERMINING RATIOS on page S5 of the Strainer Information Section for calculating NET FREE AREA of the screen to inside pipe area.

PRESSURE DROP CHART

Basket Strainers (Styles D, DV, BD, BDV, SD, SD-K, SSD, and SSD-K)

This pressure drop chart is based on the flow of clean water through the Keckley Strainer Styles listed above with screen perforations ranging from 3/64" through 1/8".

TO USE CHARTS:

Find your desired rate of flow (GPM) on the left hand side of the chart. Follow its corresponding horizontal line to the point where it intersects the diagonal line indicating the strainer pipe size. From this point of intersection, follow the vertical line down to the bottom of the chart to determine the approximate pressure drop.

CORRECTION FACTORS:

For finer mesh screens that are backed with a perforated sheet, multiply the pressure drops shown at right by the following:

- 40 mesh x 1.2
- 60 mesh x 1.4
- 80 mesh x 1.6
- 100 mesh x 1.7

