

# Style B

Y-Strainer

Cast Iron (ASTM A 126, Class B)

250 lb. Threaded



## Cast Iron Y-Strainer

### APPLICATIONS

Steam, water, oil or gas where protection from foreign matter in a pipeline is required.

### CONSTRUCTION

The Keckley Style B strainers are constructed from rugged cast iron castings that are machined to exacting specifications.

### FEATURES

The Keckley Style B features a tapered bushing in sizes 1/4" thru 2" and bolted cover with gasket for sizes 2-1/2", 3" and 4". All Keckley Style B strainers are furnished standard with a NPT blow-off connection and can be supplied with a cast iron blow-off plug upon request.

### SCREENS

Standard screens are 20 mesh 304 stainless steel through size 2". Sizes 2-1/2", 3" and 4" are furnished with 1/16" perforated 304 stainless steel screens. All screens are spot welded for maximum strength. Different size perforations and meshes are available in stainless steel, monel, and brass to meet specific media requirements. If media is not indicated, screens for *water* will be supplied.

### SELF CLEANING

Self cleaning is accomplished by opening the valve or drain plug connected to the blow-off port. **Warning:** See Maintenance Instructions on page S6 of the Strainer Information Section for additional precautions and detailed information on servicing the strainer.

### WORKING PRESSURES - NON SHOCK

NOM. RATING	MEDIA	1/4" to 4"	8 mm to 100 mm
250# (Threaded)	STEAM	250 PSI @ 406°F	1724 KPa @ 208°C
	W.O.G.	400 PSI @ 150°F	2759 KPa @ 66°C

### GOVERNMENT/MILITARY SPECIFICATIONS

Style B cast iron threaded strainers meet or exceed government specification WW-S-2739 (Supersedes MIL-S-16293).

# Style B

**Y-Strainer, 250 lb. Threaded**  
**Cast Iron (ASTM A 126, Class B)**

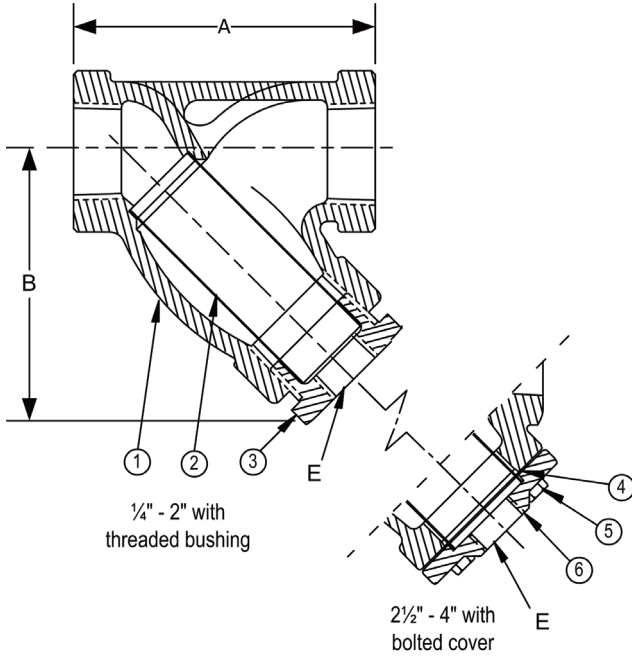

PARTS LIST		
ITEM	DESCRIPTION	MATERIAL
1	Body	Cast Iron (ASTM A 126, Class B)
2	Screen	Stainless Steel (304)
3	Bushing	Malleable Iron
4	Gasket*	Composition
5	Cap Screw*	Steel
6	Cover*	Cast Iron (ASTM A 126, Class B)

Optional: Blow-off Plug, Malleable Iron

\*2 1/2", 3" & 4" only.

**STANDARD SCREENS SUPPLIED**

SIZE		SCREEN GAGE	SCREEN PERFORMANCE					
in	mm		FOR STEAM		FOR LIQUID		OPEN AREA	
			in	mm	AREA	in	mm	AREA
1/4 to 2	8 to 50		20 MESH STAINLESS STEEL				49%	
2-1/2 to 4	65 to 100	28	3/64	1.2	33%	1/16	1.6	30%

Standard screens supplied are for **liquid service**, unless otherwise specified.  
Options: Other meshes, perforations, and screen materials are available.

SIZE		DIMENSIONS						WEIGHTS	
		A		B		E			
in	mm	in	mm	in	mm	in	mm	lbs	kgs
1/4	8	3	76	2-5/8	67	3/8	10	2	0.9
3/8	10	3	76	2-5/8	67	3/8	10	2	0.9
1/2	15	3	76	2-5/8	67	3/8	10	2	0.9
3/4	20	4	102	3-5/8	92	1/2	15	3	1.4
1	25	4-7/8	124	4-1/2	114	3/4	20	4.5	2.0
1-1/4	32	5-1/8	130	4-3/4	121	3/4	20	6	2.7
1-1/2	40	5-3/4	146	4-7/8	124	1	25	8	3.6
2	50	7-1/4	184	5-3/4	146	1-1/4	32	15.5	7.0
2-1/2	65	8-7/8	225	7-1/2	191	1-1/4	32	25	11.3
3	80	10	254	8	203	1-1/2	40	36	16.3
4	100	15-1/4	387	12-1/2	318	2	50	95	43.1

Certified dimensional drawings are available upon request.

†This table reflects only the nearest metric equivalents.

**FLOW COEFFICIENTS**

Size	C <sub>v</sub>	Size	C <sub>v</sub>	Size	C <sub>v</sub>
1/2"	9.5	1-1/4"	44.9	2-1/2"	129.7
3/4"	18.7	1-1/2"	61	3"	161.3
1"	30	2"	98	4"	256.2

**TOTAL SCREEN AREA**

Size	(in <sup>2</sup> )	Size	(in <sup>2</sup> )	Size	(in <sup>2</sup> )
1/2"	5.50	1-1/4"	18.69	2-1/2"	54.13
3/4"	8.59	1-1/2"	23.37	3"	73.51
1"	15.22	2"	36.23	4"	154.98

\*See DETERMINING RATIOS on page S5 of the Strainer Information Section for calculating NET FREE AREA of the screen to inside pipe area.

**PRESSURE vs. TEMPERATURE CHART**

250# Threaded Cast Iron (ASTM A 126, Class B)

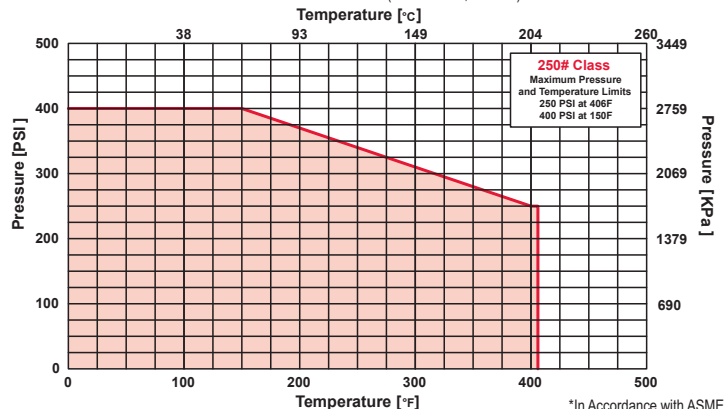

\*In Accordance with ASME B16.4



# PRESSURE DROP CHART

## Threaded “Y” Pattern Strainers (Styles B, BDI, E-150, F-150, F-300, SB, SB-7, SSB and SSB-7)

This pressure drop chart is based on the flow of clean water through the Keckley “Y” strainers listed above with screen perforations ranging from 3/64” through 1/8” and is additionally for use with those units equipped with a 20 mesh screen as standard.

**TO USE CHARTS:**

Find your desired rate of flow (GPM) on the left hand side of the chart. Follow its corresponding horizontal line to the point where it intersects the diagonal line indicating the strainer pipe size. From this point of intersection, follow the vertical line down to the bottom of the chart to determine the approximate pressure drop.

**CORRECTION FACTORS:**

For finer mesh screens that are backed with a perforated sheet, multiply the pressure drops shown at right by the following:

- 40 mesh        x 1.2
- 60 mesh        x 1.4
- 80 mesh        x 1.6
- 100 mesh       x 1.7

