

WARING
COMMERCIAL

MX1050XT

64 oz. BPA-Free copolyester container

MX1050XTP

32-48 oz. BPA-Free copolyester container

MX1050XTS

64 oz. stainless steel container

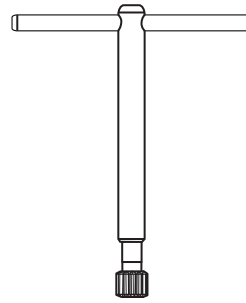

503351
MX Coupling Wrench
(optional)



013304
NSF Seal

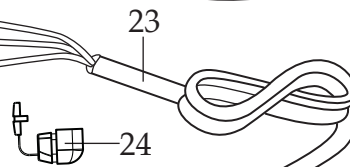
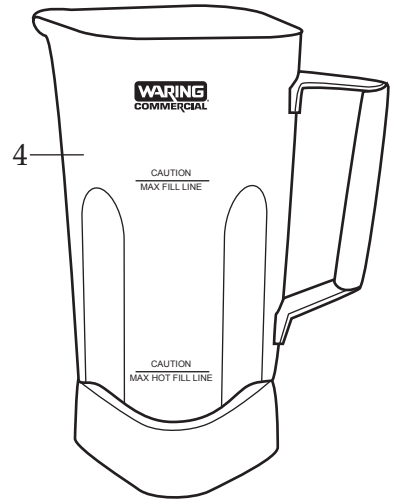
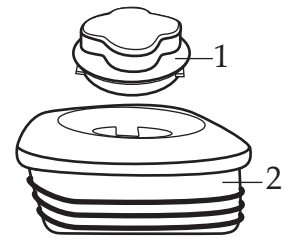
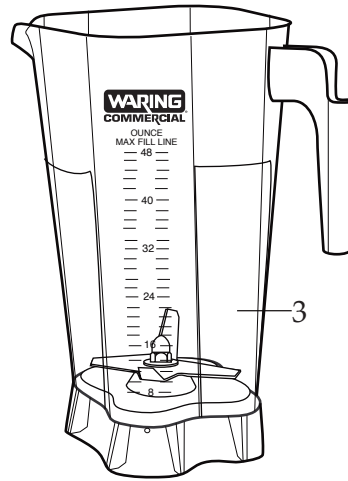
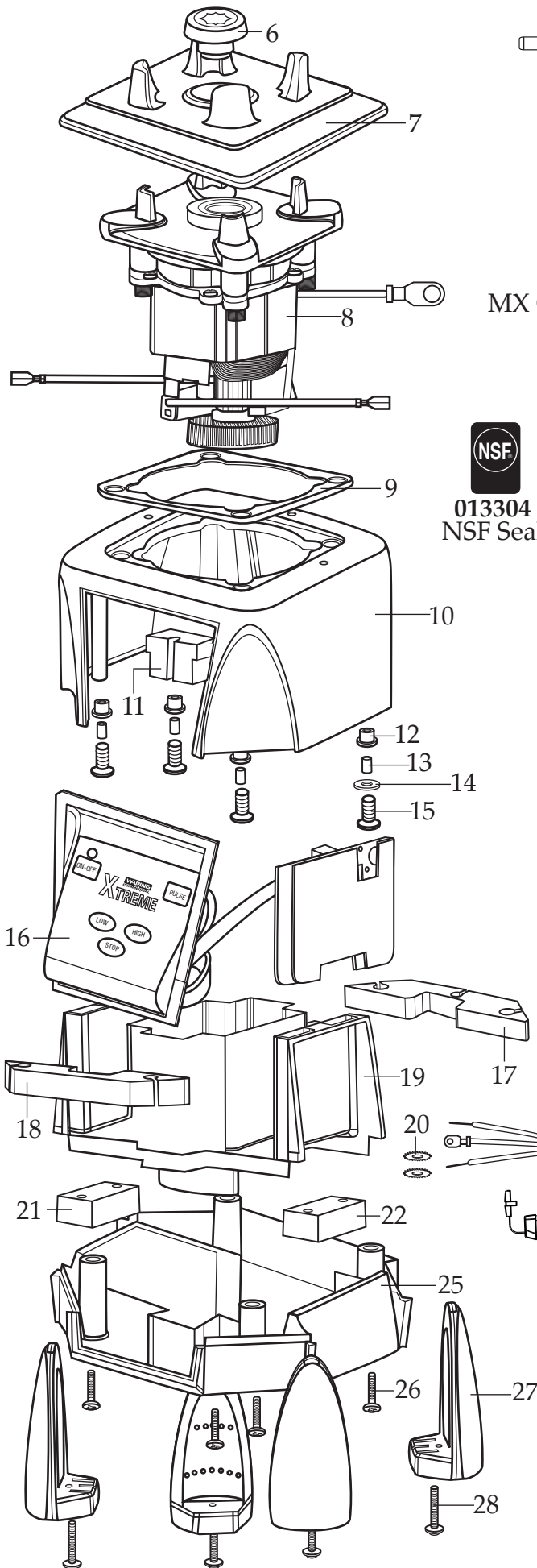

Unit Information

Limited 3 Year Motor Warranty
Two Year Parts & Labor
60Hz – 13 Amps
Height 19" – Weight 15 lbs.
3 HP Motor
30,000+ RPM's
One Piece Dishwasher Safe
Removable Jar Pad

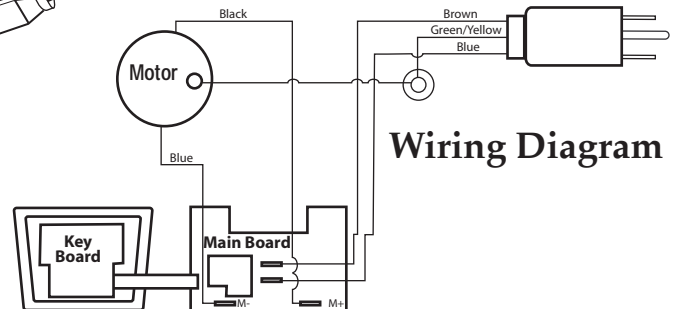

Wiring Diagram

Catalog	Model
MX1050XT	MX1050XT11
MX1050XTP	MX1050XT21
MX1050XTS	MX1050XT31



Illustration #	Part #	Description
1	026425-E	Jar Lid Cover
2	026424-V	Jar Lid
3	503398	Jar with Blending Assembly (64 oz. Eastman)
4	503346	Jar with Blending Assembly (64 oz. stainless steel)
5	503348	Jar with Blending Assembly (32-48 oz. Eastman)
6	028538	Drive Clutch
7	026442	Jar Pad
8	028100	Motor
9	026437	Dampening Plate Gasket
10	028032-09	Top Housing (black)
11	028541	Motor Foam (2 Required)
12	026439	Dampening Plate Bushing (4 Required)
13	026453	Dampening Plate Sleeve (4 Required)
14	026459	Washer
15	028929	Screw (4 Required)
	026459	Washer (4 Required <i>older units</i>)
	026455	Screw (4 Required <i>older units</i>)
16	029809	Soft Start Control Panel
	028389	Control Panel (<i>2nd generation & older units</i>)
17	028248	Housing Foam Rear Baffle
18	028249	Housing Foam Front Baffle
19	028240	Motor Housing
20	002943	Washer (2 Required)
21	028247	Bottom Housing Foam Baffle
22	028542	Foam Baffle
23	026925	Cord Set
24	007556	Strain Relief
25	028241-09-x	Bottom Housing (black)
26	012505	Screw (4 Required)
27	026430	Corner Post (4 Required)
28	028928	Screw (4 Required)
	026459	Washer (4 Required <i>older units</i>)
	012505	Screw (4 Required <i>older units</i>)

Catalog	Model
MX1050XT	MX1050XT11
MX1050XTP	MX1050XT21
MX1050XTS	MX1050XT31

Waring Factory Service Center
 314 Ella T. Grasso Ave.
 Torrington, CT 06790
 Tele. 1-800-269-6640
 Fax 860-496-9017
 www.waringcommercialproducts.com

Illustration #	Part #	Description
29	503345	Blade Assembly
30	024271	O Ring
31	024268	Nut Gasket
32	029631	Bearing Holder Nut
33	026423-E	64 oz. Eastman Container
34	503308	32-48 oz. Eastman Container
35	026798	Support Washer
36	026648	64 oz. Stainless Steel Container
37	026649	Container Support
38	026797	Bearing Holder Gasket
39	026796	Bearing Holder Washer
40	026795	Stainless Steel Jar Bearing Holder Nut

Notes for 503398 & 503348 :

Torque 100-125 in/lbs

Sealant all around the threads, fill in flats.
 Dow Corning Sealant RTV 733

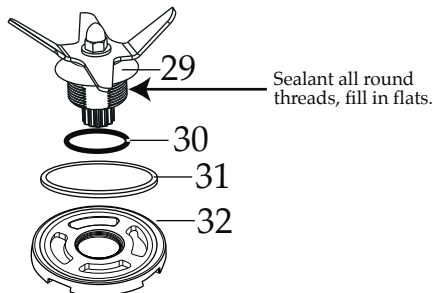

031060
Blending Assembly Kit

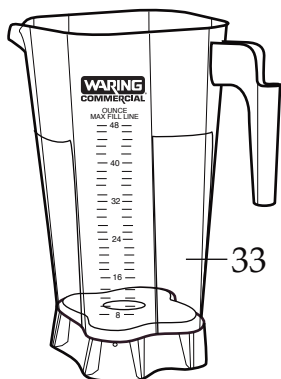

Notes for 503346 :

Torque 100-125 in/lbs

Sealant applied all around indicated areas.
 Dow Corning Sealant RTV 733

Lubricant applied to O Ring
 Dow Corning 200 (R) Fluid

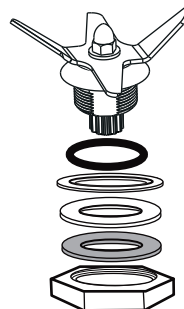

032483
Blending Assembly Kit

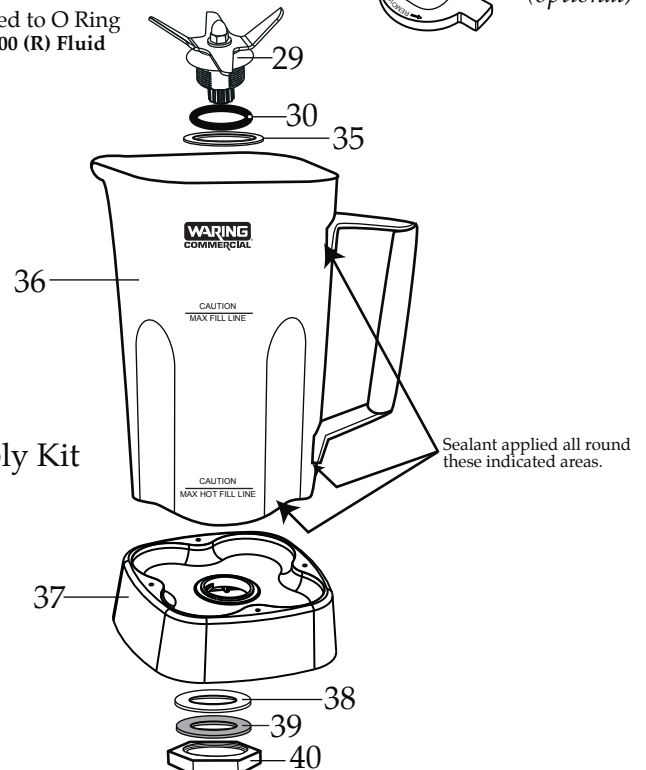
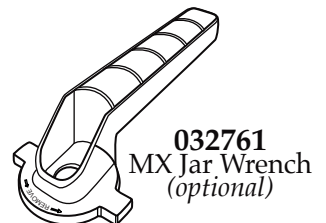

503346 - Stainless Steel Container