

# WARING COMMERCIAL®



**019972**  
Cleaning Brush



**013304**  
NSF Seal

**FP2000** *no longer in production*  
**FP2100** *no longer in production*  
**FP2200** /Batch Bowl & Continuous Feed  
**FP2200U** /Unipro with CAF22 & CAF26

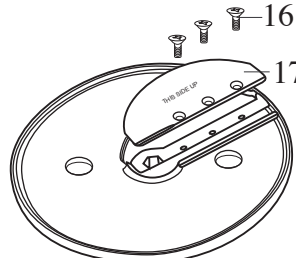
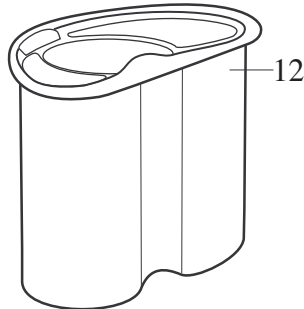
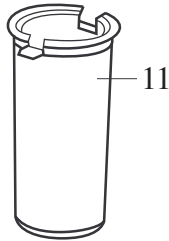
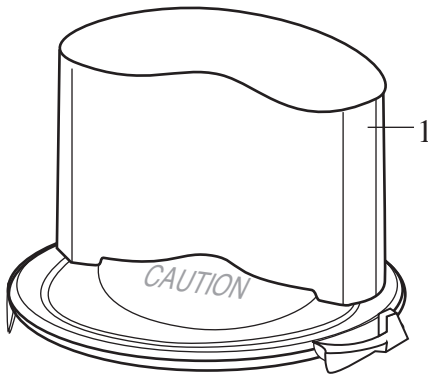

**024165**  
1/8" Slicer (CAF12)

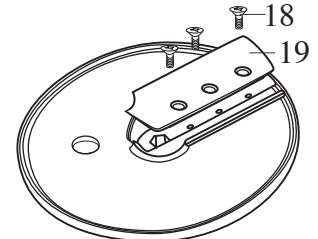

**024171**  
1/2" Slicer (CAF18)

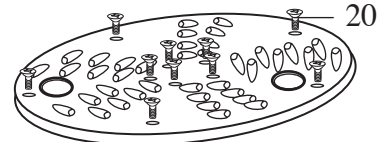

**024173**  
3/16" Shredder (CAF20)

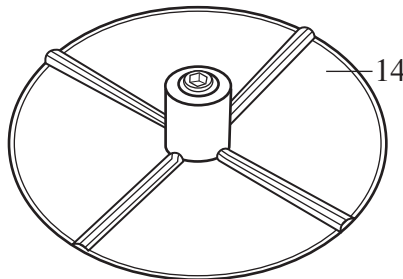
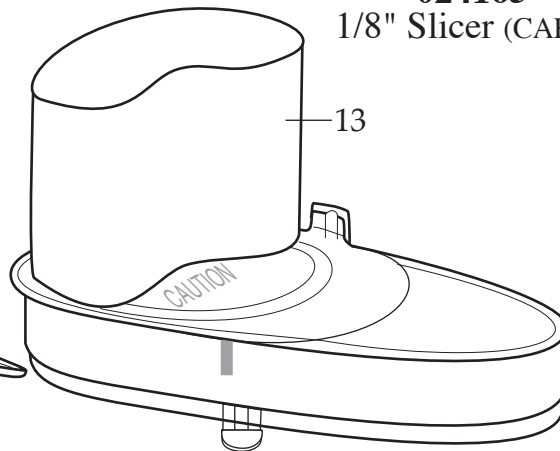

**024176**  
1/2" Dicer (CAF24)

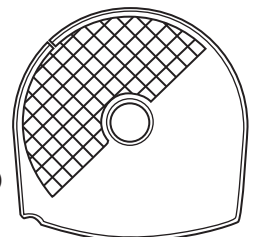
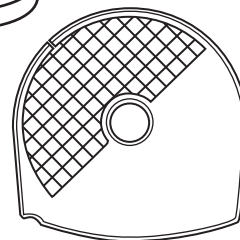

**024177**  
3/4" Dicer (CAF25)

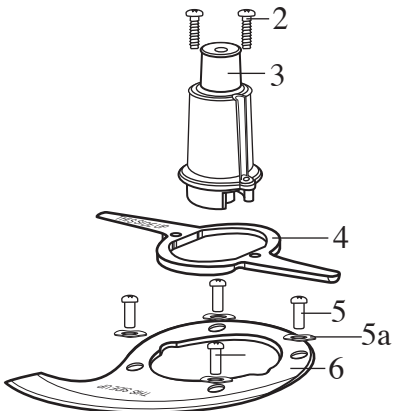

**503228** (*current production*)  
S Blade Cutter Assembly

**502499** (*older units & 2nd generation*)  
S Blade Cutter Assembly

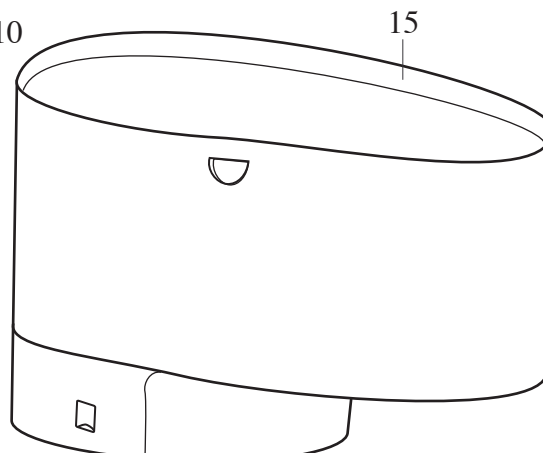
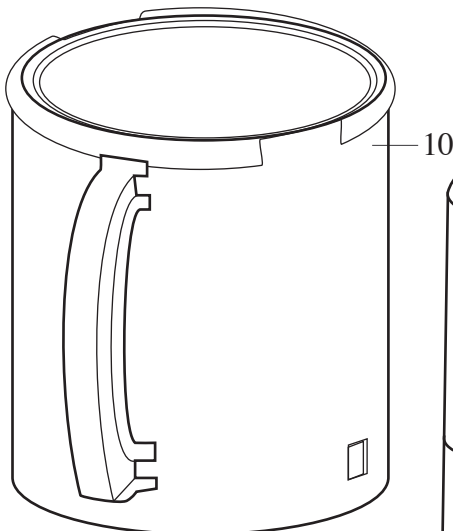

## Unit Information

50/60 HZ  
 12.0 Amps.  
 3/4 HP  
 Round work bowl can hold  
 4 qts. wet and 6 qts. dry  
 Continuous feed can process  
 1,400 lbs. per hour

# WARING COMMERCIAL<sup>®</sup>





**FP2000** *no longer in production*

**FP2100** *no longer in production*

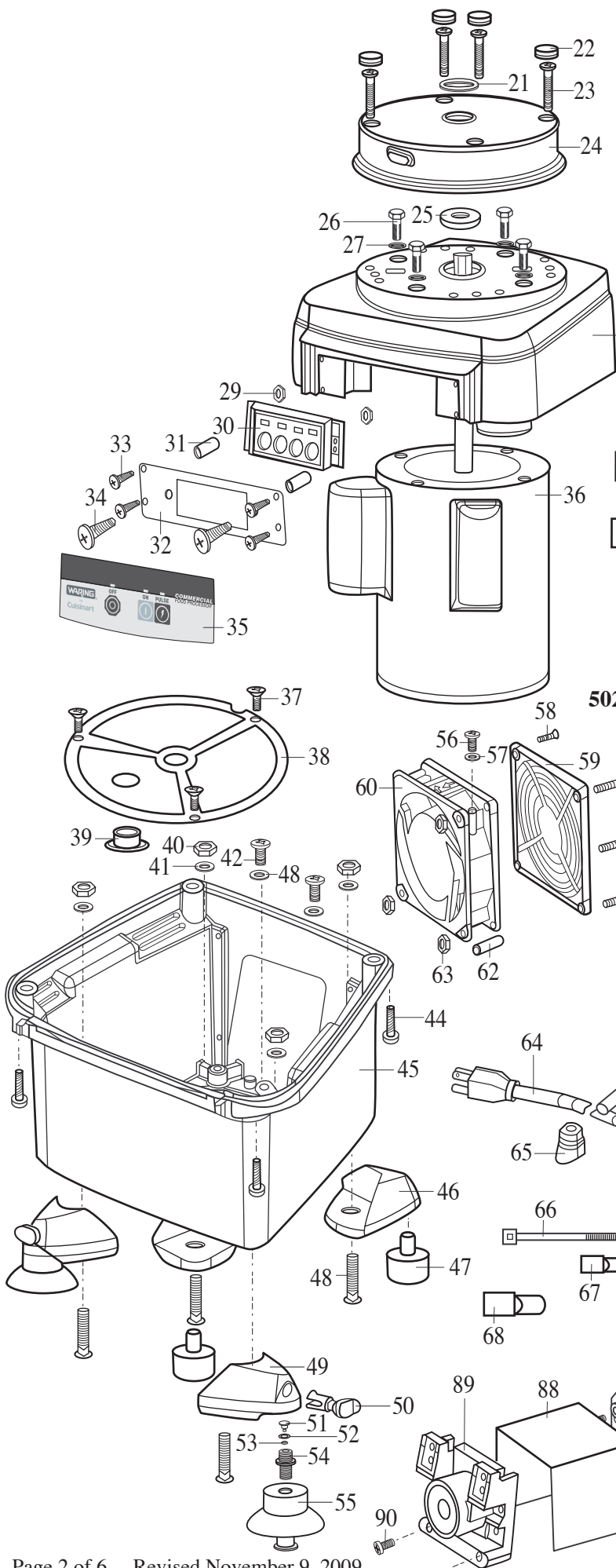
**FP2200** /Batch Bowl & Continuous Feed

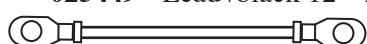
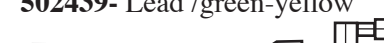
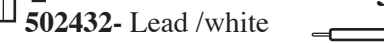
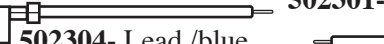
**FP2200U** /Unipro with CAF22 & CAF26





-  **023449** - Lead /black 12" 2 Req.'d
-  **502439**- Lead /green-yellow
-  **502431**- Lead /white
-  **502432**- Lead /white
-  **502301**- Lead /brown 2 Req.'d
-  **502304**- Lead /blue
-  **502302**- Lead /brown 2 Req.'d
-  **502434**- Lead /white
-  **502436**- Lead /white FP2200U (*older units*)

**Catalog**  
 FP2000  
 FP2100  
 FP2200/FP2200U

**Model**  
 32FP18  
 32FP19  
 32FP20

**Waring Factory Service Center**  
 314 Ella T. Grasso Ave.  
 Torrington, CT 06790  
 Tele. 1-800-269-6640  
 Fax 860-496-9017  
 www.waringproducts.com

<b>Illustration #</b>	<b>Part #</b>	<b>Description</b>
1	502503	Batch Bowl Cover Assy.
2	024005	Screw 2 Req.'d
3	029372 023988	Top Center Hub <i>(current production)</i> Top Center Hub <i>(2nd generation &amp; older units)</i>
4	019670	Mid Blade
5	029370 019984	Special Nut 4 Req.'d <i>(current production)</i> Special Nut 4 Req.'d <i>(2nd generation &amp; older units)</i>
5a	029371	Wave Washer 4 Req.'d <i>(current production)</i>
6	023940	Cutter Blade
7	029373 023989	Center Hub <i>(current production)</i> Center Hub <i>(2nd generation &amp; older units)</i>
8	023940 019580	Cutter Blade Lower "S" Blade Cutter <i>(2nd generation &amp; older units) N/A Use 503228</i>
9	029369 023029	Special Screw 4 Req.'d <i>(current production)</i> Special Screw 4 Req.'d <i>(2nd generation &amp; older units)</i>
10	019578	Batch Bowl
11	025285 024032 019834	Plunger Insert /dark gray <i>(current production &amp; 2nd generation)</i> Plunger Insert /light gray <i>(older units)</i> Plunger Insert /clear <i>(older units before Sept. 99)</i>
12	025284 019579	Plunger /dark gray- kidney shape  Plunger /white - half circle shape <i>(older units before Sept. 99)</i> 
13	502583 502504 502293	Continuous Feed Cover Assy. /kidney plunger <i>(current production)</i> Continuous Feed Cover Assy. /kidney plunger <i>(older units)</i> Continuous Feed Cover Assy. /half circle plunger <i>(older units before Sept. 99)</i>
14	025286	Slinger Disk /gray
15	025281 019581	Continuous Feed Bowl /dark gray <i>(current production &amp; 2nd generation)</i> Continuous Feed Bowl /light gray <i>(older units)</i>
16	019983	Flat Head Screw 3 Req.'d
17	019689	Slicing Blade
18	023464	Flat Head Screw 3 Req.'d
19	023055	Slicing Blade
20	019981	Screw 10 Req.'d
21	018008	Washer
22	025294 019812	Plug 4 Req.'d /dark gray <i>(current production &amp; 2nd generation)</i> Plug 4 Req.'d /light gray <i>(older units)</i> 4 Req.'d
23	019974	Screw 4 Req.'d
24	019566	Locking Ring
25	018004	Seal
26	020325	Hex Bolt 4 Req.'d
27	021082	Washer 4 Req.'d

**Catalog**

FP2000  
 FP2100  
 FP2200/FP2200U

**Model**

32FP18  
 32FP19  
 32FP20



<b>Illustration #</b>	<b>Part #</b>	<b>Description</b>
28	502963 502385	Top Housing /dark gray ( <i>current production &amp; 2nd generation</i> ) Top Housing /light gray ( <i>older units</i> ) N/A Use 502963
29	001856	Kep Nut 2 Req.'d
30	019954	Tap Touch Switch
31	019641	Switch Spacer 2 Req.'d
32	019572	Switch Plate
33	019096	Screw 4 Req.'d
34	019973	Screw 2 Req.'d
35	019573	Name Plate
36	019574	Motor 3/4 HP
37	016317	Screw 3 Req.'d
38	023233	Screen /punched
39	023211	Snap Bushing
40	023073	Nut 4 Req.'d
41	018314	Washer 4 Req.'d
42	017408	Screw 2 Req.'d
43	002943	Washer 2 Req.'d
44	019098	Screw 4 Req.'d
45	025282 019787	Bottom Housing /dark gray ( <i>current production &amp; 2nd generation</i> ) Bottom Housing /light gray ( <i>older units</i> ) N/A Use 025282
46	025292 019968	Rear Foot Support /dark gray 2 Req.'d ( <i>current production &amp; 2nd generation</i> ) Rear Foot Support /light gray 2 Req.'d ( <i>older units</i> )
47	018790	Foot 2 Req.'d
48	023072	Carriage Bolt 4 Req.'d
49	024293 024052	Front Foot Support /dark gray 2 Req.'d ( <i>current production &amp; 2nd generation</i> ) Front Foot Support /light gray 2 Req.'d ( <i>older units</i> )
50	024037	Front Foot Actuator 2 Req.'d
51	024039	Valve Foot Pin 2 Req.'d
52	024040	Curved Spring Washer 2 Req.'d
53	024042	Foot "O" Ring 2 Req.'d
54	024038	Actuator Shaft 2 Req.'d
55	024053	Suction Cup Foot 2 Req.'d
56	023437	Screw
57	002943	Washer
58	023436	Screw

**Catalog**

FP2000

FP2100

FP2200/FP2200U

**Model**

32FP18

32FP19

32FP20



<b>Illustration #</b>	<b>Part #</b>	<b>Description</b>
59	023412	Fan Guard ( <i>current production &amp; 2nd generation</i> )
	023454	Fan Guard ( <i>older units</i> )
60	023411	Fan
61	023416	Screw 3 Req.'d
62	002613	Insulating Sleeve
63	001856	Kep Nut 3 Req.'d
64	014236	Cord Set
65	018811	Strain Relief
66	013731	Cable Tie 3 Req.'d
67	012409	Crimp Connector /small 3 Req.'d
68	019123	Crimp Connector /large 2 Req.'d
69	025294	Plug /dark gray ( <i>current production &amp; 2nd generation</i> )
	019812	Plug /light gray ( <i>older units</i> )
70	019978	Screw
71	025288	Back Plate /dark gray ( <i>current production &amp; 2nd generation</i> )
	019055	Back Plate /light gray ( <i>older units</i> )
72	019980	Screw 2 Req.'d
73	019979	Clamp Sensor
74	019977	Screw 2 Req.'d
75	021741	Sensor
76	025289	Insert /dark gray ( <i>current production &amp; 2nd generation</i> )
	019562	Insert /light gray ( <i>older units</i> )
77	502578	Tower Assembly /dark gray
78	502306	Lead
79	023936	Lead /black 15 1/2"
80	025294	Plug /dark gray 4 Req.'d ( <i>current production &amp; 2nd generation</i> )
	019812	Plug /light gray 4 Req.'d ( <i>older units</i> )
81	023325	Screw 4 Req.'d
82	023328	Tower Gasket
83	002943	Washer 2 Req.'d
84	016716	Hex Nut 2 Req.'d
85	023326	Relay Bracket
86	002943	Washer 2 Req.'d
87	016690	Screw 2 Req.'d
88	023360	Splash Guard
89	019569	Relay
90	023347	Screw 2 Req.'d

