

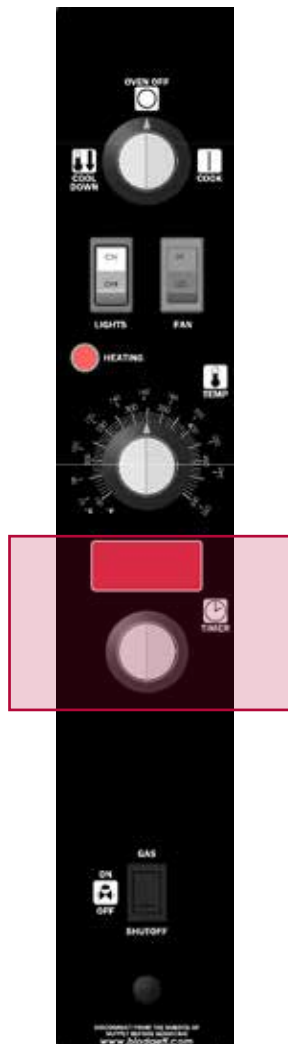

Specification Change Notification

To keep supply moving forward, we are switching specification of the Zephaire ovens to the proven, durable SSI-M control. Please see below for details.



SSI-D

Solid state infinite control with digital timer and dial thermostat. More accurate control with linear temperature referencing (LTR).

The only difference between these controls is the mechanism for entering cook time.

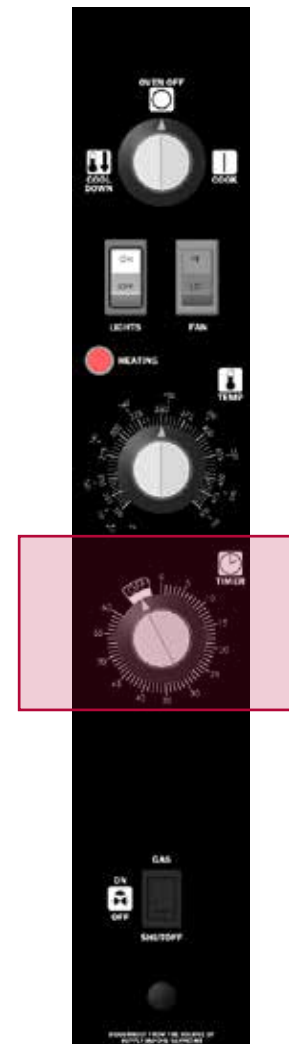

SSI-M

Solid state infinite control with separate dials for thermostat and timer. More accurate control with linear temperature referencing (LTR).



ZEPHAIRE-100-G-ES

ZEPHAIRE-100-G-ES

Full-Size, Standard Depth
Gas Convection Oven



Project _____

Item No. _____

Quantity _____

Standard depth baking compartment - accepts five 18" x 26" standard full-size baking pans in left-to-right positions. All data is shown per oven section, unless otherwise indicated.

Refer to operator manual specification chart for listed model names.

EXTERIOR CONSTRUCTION

- Full angle-iron frame
- Stainless steel front, top, and sides
- Dual pane thermal glass windows encased in stainless steel door frames
- Powder coated door handle with simultaneous door operation
- Triple-mounted pressure lock door design with turnbuckle assembly
- 1" solid block plus 1" mineral fiber insulation for a total of 2" of insulation

INTERIOR CONSTRUCTION

- Double-sided porcelainized baking compartment liner (16 gauge)
- Stainless steel combustion chamber
- Single inlet blower wheel
- Five chrome-plated racks, eleven rack positions with a minimum of 1-5/8" (41mm) spacing
- Interior lightsx

OPERATION

- Direct Fired Gas system
- Electronic spark ignition control system
- Removable inshot burners
- Internal pressure regulator
- Manual gas service cut-off switch located on the front of the control panel
- Solid state thermostat with temperature control range of 200°F (93°C) to 500°F (260°C)
- Two speed fan motor
- 3/4 horsepower blower motor with automatic thermal overload protection
- Control area cooling fan

STANDARD FEATURES

- SSI-D - Solid state infinite control w/digital timer
- 25" (635mm) adjustable stainless steel legs (for single units)
- 6" (152mm) adjustable stainless steel legs (for double sections)
- Two year parts and two year labor warranty
- Three year limited oven door warranty*

* For all international markets, contact your local distributor.

NOTE: The company reserves the right to make substitutions of components without prior notice

OPTIONS AND ACCESSORIES

(AT ADDITIONAL CHARGE)

- **Legs, casters & stands**
 - 6" (152mm) seismic legs
 - 6" (152mm) casters
 - 4" (102mm) low profile casters (double only)
 - 25" (635mm) stainless steel stand w/rack guides
 - 29" (737mm) stainless steel, fully welded open stand with pan supports
- **Gas hose w/quick disconnect restraining device**
 - 48" (1219mm) hose
 - 36" (914mm) hose
- SSD - Solid state digital control with LED display, Cook & Hold and Pulse Plus®
- Extra oven racks
- Stainless steel solid back panel
- Gas manifold (for double sections)
- Prison package (includes security control panel and stainless steel back)
- Flue connector
- Direct vent

OPTIONS AND ACCESSORIES

(AT NO ADDITIONAL CHARGE)

- Solid stainless steel doors
- SSI-M - Solid state infinite control w/manual timer



www.blodgett.com

42 Allen Martin Drive, Essex Junction, VT 05452
Phone: (802) 658-6600 | Fax: (802) 864-0183



ZEPHAIRE-100-G-ES

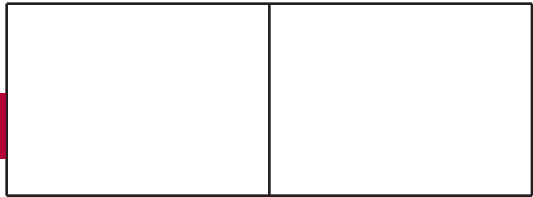

APPROVAL/STAMP

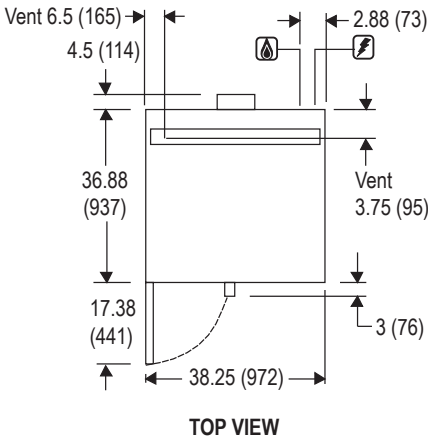

TOP VIEW

DIMENSIONS ARE IN INCHES (MM)

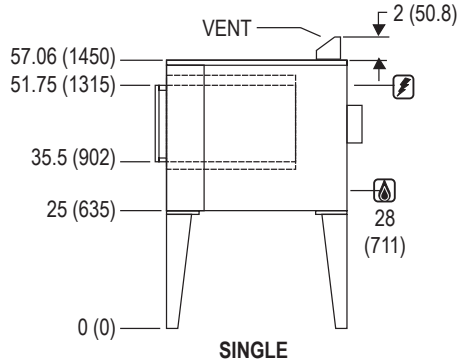

SINGLE

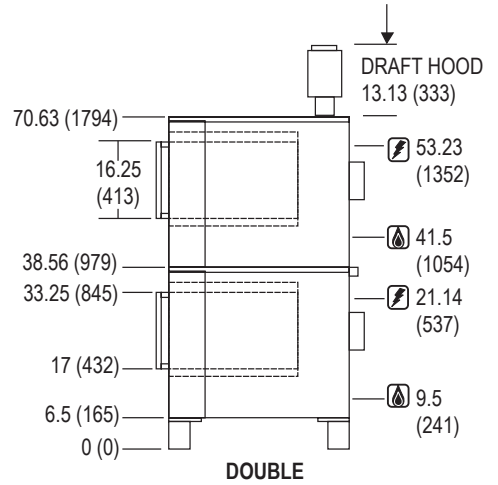

DOUBLE

SHORT FORM SPECIFICATIONS Provide Blodgett full-size convection oven model ZEPHAIRE-100-G-ES, (single/double) compartment. Each compartment shall have (porcelainized/stainless) steel liner and shall accept five 18" x 26" standard full-size bake pans. Stainless steel front, top and sides. Doors shall be (solid stainless steel/dual pane thermal glass windows) with single powder coated handle and simultaneous operation. Unit shall be gas heated with electronic spark ignition and shall cook by means of a direct fired system with a gas shutoff switch on the front of the control panel. Air in baking chamber distributed by single inlet blower wheel powered by a two-speed, 3/4 HP motor with thermal overload protection. Each chamber shall be fitted with two lamps and five chrome-plated removable racks. Control panel shall be recessed with Cook/Cool Down mode selector, solid state (manual) infinite thermostat (200- 500°F), and 60-minute timer. Provide two years parts and labor and three year door warranty. Provide options and accessories as indicated.

DIMENSIONS

- Floor space** 38-1/4" (972mm) W x 36-7/8" (937mm) D
- Interior** 29" (737mm) W x 20" (508mm) H x 24-1/4" (616mm) D
- If oven is on casters**
 - Single Add 4-1/2" (114mm) to height
 - Double Height dimensions remain the same
 - Double Low Profile Subtract 2.5" (64mm) from all height dimensions

PRODUCT CLEARANCE

- From combustible and non-combustible construction** 0" (0 mm)

MINIMUM ENTRY CLEARANCE

- Uncrated** 32-1/16" (814mm)
- Crated** 37-1/2" (953mm)

SHIPPING INFORMATION

- Approx. Weight**
 - Single 590 lbs. (268 kg)
 - Double 1095 lbs. (497 kg)

Crate Size

37-1/2" (952mm) x 43-1/2" (1105mm) x 51-3/4" (1315mm)
(2 crates required for double)

GAS SUPPLY (per section)

- 3/4" NPT
- Inlet Pressure**
 - Natural Gas 7.0" W.C. min. - 10.5" W.C. max.
 - Propane 11.0" W.C. min. - 13.0" W.C. max.
- Manifold Pressure**
 - Natural Gas 3.5" W.C.
 - Propane 10" W.C.

MAXIMUM INPUT

45,000 BTU/hr (13.2 Kw) per oven section

POWER SUPPLY

- 115 VAC, 1 phase, 8 Amp, 60 Hz., 2-wire with ground, 3/4 H.P., 2 speed motor, 1120 and 1680 RPM
- 6' (1.8m) electric cord set furnished on 115 VAC ovens only.
- 230V CE model, 1 phase, 3 Amp, 50 Hz., 2-wire with ground, 1/2 H.P., 2 speed motor, 1440/930