

Water Specialist - CWS-18 Cabinet

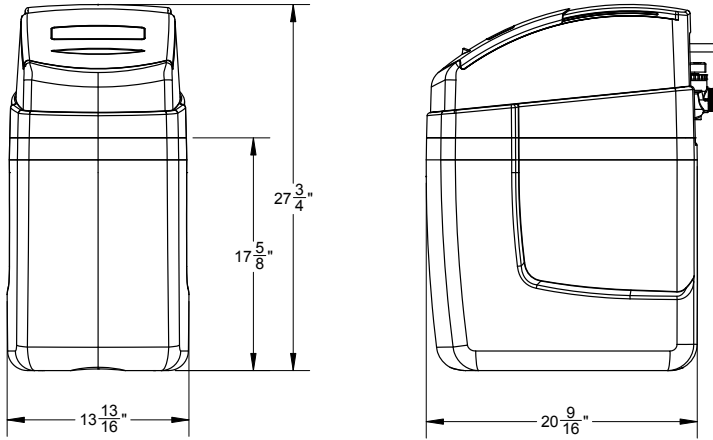

The Water Specialist - CWS-18 Cabinet accepts 18" tall mineral tanks.

Tank Size	Liquid Capacity		Salt Capacity		
	in.	gal.	liters	lbs.	Kg
8 x 18	14	3.7	142	64	
9 x 18	13	3.5	133	60	
10 x 18	12	3.3	124	56	

Water Specialist - CWS-35 Cabinet

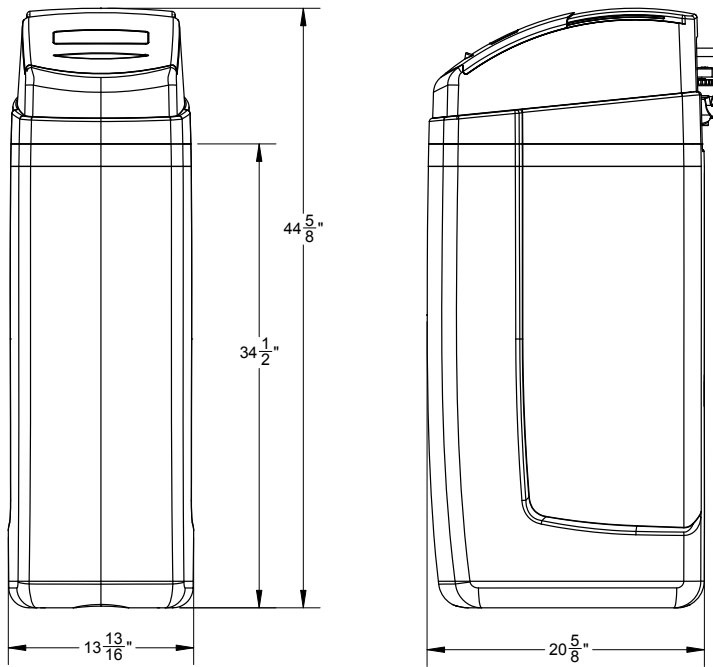

The Water Specialist – CWS-35 Cabinet accepts 35" tall mineral tanks up to a 12" diameter to maximize system capability.

Tank Size	Liquid Capacity		Salt Capacity		
	in.	gal.	liters	lbs.	Kg
8 x 35	28	7.5	285	129	
9 x 35	27	7.0	279	126	
10 x 35	25	6.5	258	117	
12 x 35	20	5.3	208	94	

The cabinet will be available for use with 18" and 35" tall media tanks including a 12" x 35" tank to maximize resin capacity. Control Valve and Mineral Tank not included.

ORDERING INFORMATION

The cabinet requires **two** part numbers when ordering, one part number for the base assembly with the brine system and one part number for the top trim plate and the cover assembly.

ORDER NUMBER	DESCRIPTION	QUANTITY PER CARTON	WEIGHT PER CARTON
J2TCWS-HEH	CWS Top Assembly Light Gray/Dark Gray	1	8 lbs.
J2TCWS-BEB	CWS Top Assembly Light Gray/Blue	1	8 lbs.
J2B18E	CWS18 Bottom Assembly Light Gray with 474 Assembly	1	10 lbs.
J2B35E	CWS35 Bottom Assembly Light Gray with 474 Assembly	1	17 lbs.