

FLECK 5800 SXT METERED WATER SOFTENER

› INSTALLATION GUIDE

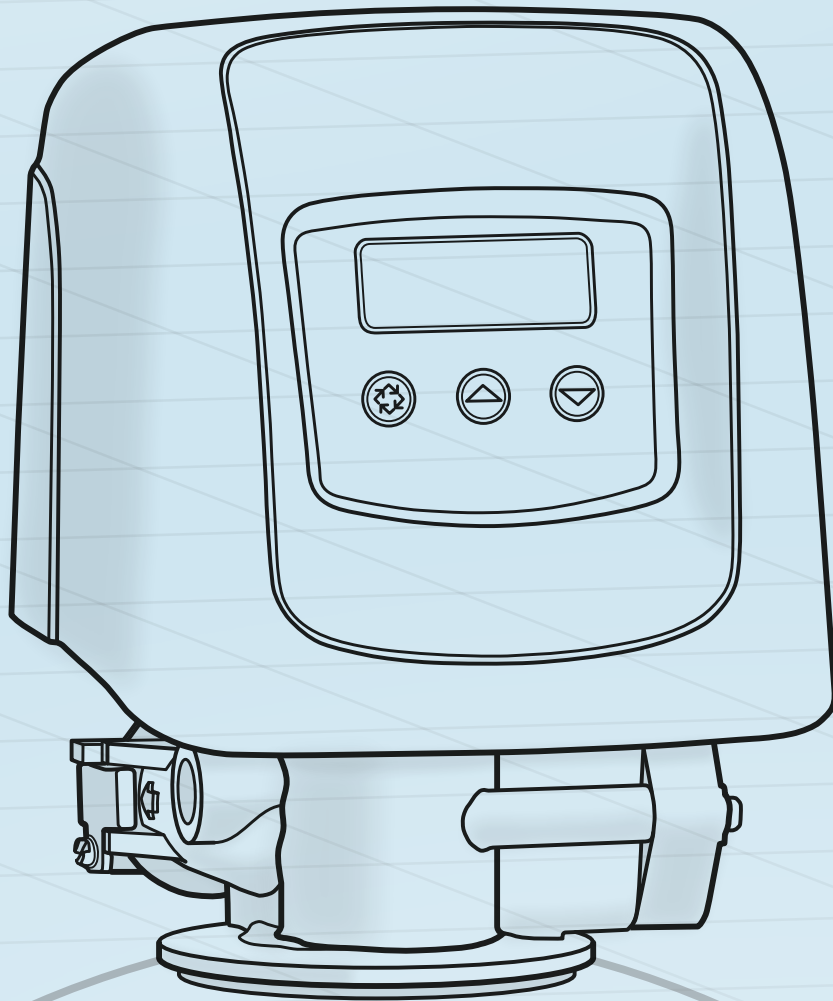

›GENERAL REFERENCE

Please take a moment to review this page in order to familiarize yourself with these ports on the valve and the programming values below. It is crucial not to mistake the inlet port with the outlet port. Mistaking and reversing the inlet and outlet ports will lead to failure of your softener system.

As you work through this guide, please make sure to follow all instructions exactly and to make special note of the bolded instructions and warning symbols. **PDF viewers may click underlined text to jump to that page or the page number in the bottom corner of every page to jump to the table of contents.** All our installation guides may be found on our site under "Information."

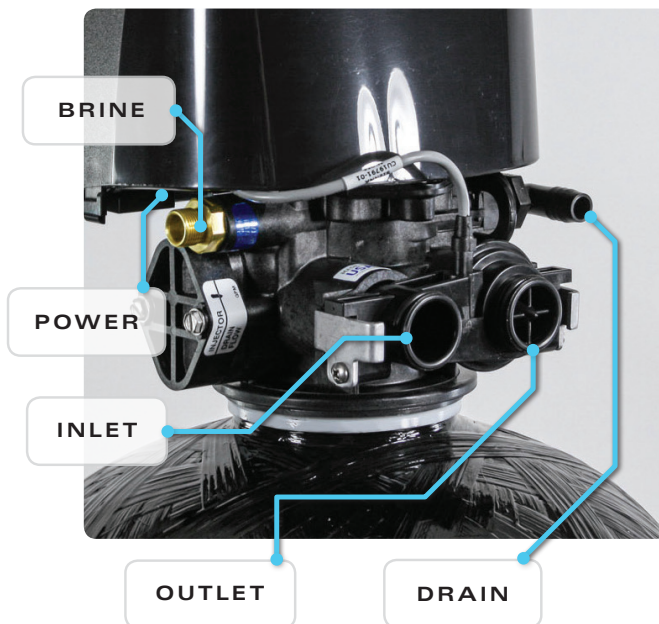

›QUICK START

To the right are the program settings for your softener. **If not all of the values are filled in, you can calculate the missing values on pages 4 and 5 of this guide.** There we will cover identifying the 3 essential values of **H - HARDNESS**, **C - UNIT CAPACITY**, and **BF - BRINE FILL**. The remaining values that are already filled in are general standards for all softener sizes and hardness levels.

MASTER PROGRAMMING MODE: To enter in/check the adjacent values of your system, follow these steps: With either the up or down arrow button, change the clock to 12:01 PM, set the time by clicking the left-most CYCLE / REGEN button, and then hold both the up and down arrow buttons for 5 seconds to enter master programming mode. Change values with the arrow buttons and set each value and advance to the next setting by clicking the CYCLE / REGEN button.

A more in-depth guide to programming the Fleck 5800 SXT is provided beginning on **page 12**.

SETTING	INPUT VALUE
DF - Display Format	GAL - Gallons
VT - Valve Type	5800
RF - Regeneration Flow	dF1b
CT - Control Type	Fd - Flow Delayed
C - UNIT CAPACITY	<u> </u> ,000 Grains
H - HARDNESS	<u> </u> Grains per Gallon
RS - Reserve Selection	SF
SF - Safety Factor	15%
DO - Day Override	14 Days
RT - Regen Time	2:00 AM
BW - Backwash	10 Minutes
BD - Brine Draw	60 Minutes
RR - Rapid Rinse	12 Minutes
BF - BRINE FILL	<u> </u> Minutes
FM - Flow Meter Type	t0.7 or P0.7
RE - Time Relay	OFF
VR - Flow Relay	OFF

FM - Flow Meter Type	
 t0.7	 P0.7

Job Number: _____

Model Number: _____

Mineral Tank Size: _____

PREFACE

Thank you for your purchase of a new water softener with Fleck 5800 SXT Meter Control Valve from QualityWaterForLess.com! We have put together these instructions as reference and to be used as general installation guidelines. **It is always recommended that a licensed plumber perform all installation work according to all local codes.** We at QualityWaterForLess.com cannot assume responsibility for improper installation, application, or injury or damage as a result of improper installation.

›TABLE OF CONTENTS

Page 2	Meter Control Valve Ports and Programming Reference
Page 3	Table of Contents
Page 4	Calculating your Hardness Level, and Salt Grid Table
Page 5	Tank Size, Hardness, Unit Capacity, Salt Setting, and Salt Grid Table
Page 6	Pre-Installation and Filling the Tank
Page 7	Installing the Fleck 5800 SXT Valve onto the Tank
Page 8	Plumbing the Fleck 5800 SXT Valve into your Home
Page 9	Making the Brine Tank Connection
Page 11	Making the Drain Connection
Page 12	Programming: Entering Master Programming Mode and Initial Programming
Page 13	Programming: Control Type, Capacity, Hardness, Reserve, Day Override
Page 14	Programming: Regeneration Time, Backwash, Brine Draw, Rapid Rinse, Brine Fill, and Meter Type
Page 15	Programming: Relay and Resetting the Time
Page 16	Initial System Start-Up

1 › CALCULATING HARDNESS, CAPACITY, AND BRINE FILL









- 1) **Water Test:** Before start-up, it is crucial that you know your water's **HARDNESS** and **IRON** levels in order to set up your unit properly. If your unit is not programmed with your particular hardness level, it will either regenerate too early or too late. If you do not know your water hardness or iron levels, you can take a sample of your untreated water to a local pool shop, hardware store, or well driller (**city water has no iron**)
- 2) **Initial Hardness:** Your Hardness test results may be recorded in Grains per Gallon (gpg), Parts per Million (PPM), or Milligrams per Liter (mg/L). Note that **PPM and mg/L are the same measure** and both figures can be used interchangeably. **If you get a hardness level in PPM or mg/L, please divide this number by 17.1 to get Grains (gpg).** Ex: If your hardness is measured at 300 PPM, take $300 / 17.1 = 18$ gpg before iron

$$\text{_____ PPM Hardness} \div 17.1 = \text{_____ gpg Hardness before Iron}$$

- 3) **H - COMPENSATED HARDNESS:** Your Iron results should also be measured in either PPM or mg/L. **Take your level of iron multiplied by 5 and add it to the hardness level from the previous step.** This final figure will be your **Compensated Hardness Level** that we will program into your softener system. Ex: If your iron level is measured at 2 PPM, add $2 \times 5 = 10$ Grains of hardness to existing hardness total. $18 + 10 = 28$ Grains Total

$$\text{_____ gpg Hardness} + (\text{_____ PPM Iron} \times 5) = \text{_____ gpg } \mathbf{H - COMPENSATED HARDNESS}$$

- 4) **The compensated hardness level you just calculated will be the "H" value you use to program your softener. You may record this in the table on page 2.** Depending on your compensated hardness level, you will be able to use a different salt setting for programming and running your softener unit. The lower the hardness level, the more efficient you will be able to be with salt consumption for regeneration

	11X11" GRID	15X17" GRID	18" DIAMETER GRID
PLAIN GRID			
GRID + 3" LEGS			
GRID + 6" LEGS			

- 5) **C - UNIT CAPACITY:** In the first column, identify the **section** containing your softener tank size and then within this section, find the **row** pertaining to your **H - Compensated Hardness** level. Then look under the **C - Capacity** column to find the most efficient program value to enter for your **C - Unit Capacity** and record it **in the table on page 2**. **Note that your unit capacity program value may actually be lower than the tank's rated capacity.** This is to accommodate a lower salt dose for regeneration.
- 6) **BF - BRINE FILL:** In the first column, identify the **section** containing your softener tank size and then within this section, find the **row** pertaining to your **H - Compensated Hardness** level. Then look under the **BF - Brine Fill** column to find the most efficient program value to enter for your **BF - Brine Fill** and record it **in the table on page 2**.
- 7) **Example:** If you ordered a 64K grain capacity system and have 28 gpg compensated hardness, you would look under the 64K, 2.0 cu ft section and then look under the 25+ gpg row for your particular programming values. Note that the 11x11" and the 15x17" brine tanks are too small for the amount of brine needed to regenerate a 64K grain capacity system with 25+ gpg hardness. According to the table you would opt for an 18" diameter brine tank with a grid plus 6" legs

Tank Size	H HARDNESS	C CAPACITY	BF BRINE FILL	lbs of Salt	11x11" Grid	15x17" Grid	18x33" Grid	18x40" Grid	24x41" Grid	24x50" Grid
24K 0.75 cu ft 8x44"	0 - 12 gpg	15K	6 Min	4.5 lbs	Grid	NO GRID	NO GRID	NO GRID	TOO LARGE	TOO LARGE
	12 - 25 gpg	20K	10 Min	7.5 lbs	Grid	Grid	NO GRID	NO GRID		
	25+ gpg	24K	14 Min	11.25 lbs	Grid + 3" Legs	Grid	Grid	Grid		
32K 1.0 cu ft 9x48"	0 - 12 gpg	20K	8 Min	6 lbs	Grid	NO GRID	NO GRID	NO GRID	TOO LARGE	TOO LARGE
	12 - 25 gpg	27K	14 Min	10 lbs	Grid + 3" Legs	Grid	Grid	Grid		
	25+ gpg	32K	20 Min	15 lbs	Grid + 6" Legs	Grid + 3" Legs	Grid	Grid		
40K 1.25 cu ft 10x44"	0 - 12 gpg	25K	10 Min	7.5 lbs	Grid	Grid	NO GRID	NO GRID	TOO LARGE	TOO LARGE
	12 - 25 gpg	34K	18 Min	12.5 lbs	Grid + 3" Legs	Grid	Grid	Grid		
	25+ gpg	40K	26 Min	18.75 lbs	TOO SMALL	Grid + 3" Legs	Grid + 3" Legs	Grid + 3" Legs		
48K 1.5 cu ft 10x48"	0 - 12 gpg	30K	14 Min	9 lbs	Grid + 3" Legs	Grid	Grid	Grid	TOO LARGE	TOO LARGE
	12 - 25 gpg	41K	20 Min	15 lbs	Grid + 6" Legs	Grid + 3" Legs	Grid	Grid		
	25+ gpg	48K	30 Min	22.5 lbs	TOO SMALL	Grid + 6" Legs	Grid + 3" Legs	Grid + 3" Legs		
64K 2.0 cu ft 12x52"	0 - 12 gpg	40K	16 Min	12 lbs	Grid + 3" Legs	Grid	Grid	Grid	Grid + 5" Legs	Grid + 5" Legs
	12 - 25 gpg	54K	28 Min	20 lbs	TOO SMALL	Grid + 6" Legs	Grid + 3" Legs	Grid + 3" Legs		
	25+ gpg	64K	40 Min	30 lbs	TOO SMALL	TOO SMALL	Grid + 6" Legs	Grid + 6" Legs		
80K 2.5 cu ft 13x54"	0 - 12 gpg	50K	20 Min	15 lbs	Grid + 6" Legs	Grid + 3" Legs	Grid	Grid	Grid + 5" Legs	Grid + 5" Legs
	12 - 25 gpg	68K	34 Min	25 lbs	TOO SMALL	Grid + 6" Legs	Grid + 3" Legs	Grid + 3" Legs		
	25+ gpg	80K	50 Min	37.5 lbs	TOO SMALL	TOO SMALL	TOO SMALL	Grid + 6" Legs		
96K 3.0 cu ft 14x65"	0 - 12 gpg	60K	24 Min	18 lbs	TOO SMALL	Grid + 3" Legs	Grid + 3" Legs	Grid + 3" Legs	Grid + 6" Legs	Grid + 6" Legs
	12 - 25 gpg	81K	40 Min	30 lbs	TOO SMALL	TOO SMALL	Grid + 6" Legs	Grid + 6" Legs		
	25+ gpg	96K	60 Min	45 lbs	TOO SMALL	TOO SMALL	TOO SMALL	TOO SMALL		
120K 4.0 cu ft 16x65"	0 - 12 gpg	80K	32 Min	24 lbs	TOO SMALL	Grid + 6" Legs	Grid + 3" Legs	Grid + 3" Legs	Grid + 8" Legs	Grid + 8" Legs
	12 - 25 gpg	108K	54 Min	40 lbs	TOO SMALL	TOO SMALL	TOO SMALL	TOO SMALL		
	25+ gpg	120K	80 Min	60 lbs	TOO SMALL	TOO SMALL	TOO SMALL	TOO SMALL		

⚠️ PRE-INSTALLATION

Before assembly of your new system, be sure that the following conditions have been met for the placement of your system:

- Level, firm surface, such as concrete, on which to place the softener and salt tank (also known as a **brine** tank)
- Un-switched power source, standard US plug, 120v 60hz (the softener system includes a 5 ft power cord and plug)
- Access to the water main coming into your home. You will need to install the softener at this point to assure that water for the home is going through the system
- Nearby floor drain or standpipe to connect to the softener for use during each regeneration

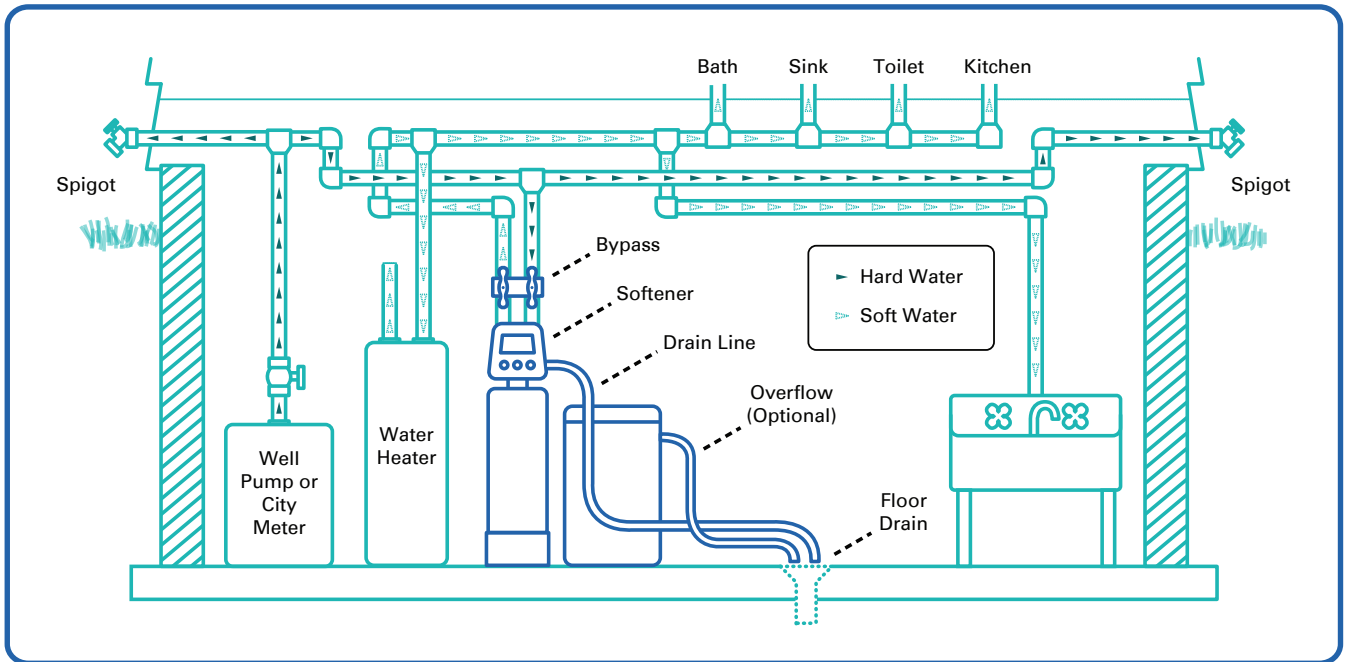

2 PLACING AND FILLING THE TANK

- 1) Choose the final location for your water softener tank and place the tank upright and level on the surface. Filling the tank may be necessary on some systems. Your tank may have also come pre-filled, and in this case you only need to unscrew the protective cap as shown in **Figure 6-A**
- 2) **If your tank is not filled**, place the riser tube into the tank as shown in **Figure 6-B**. Please make sure that the riser tube seats into the bottom of the tank and that the top of the tube is flush with the top of the tank opening



FIGURE 6-A

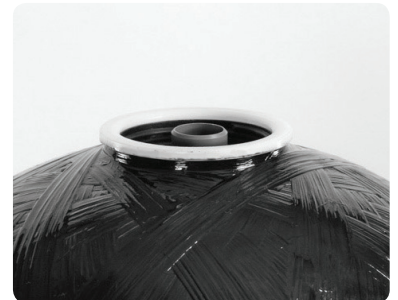

FIGURE 6-B

- 3) Before filling the tank, place a piece of painter's tape over the top of the riser to prevent resin from dropping down inside the riser tube as shown in **Figure 7-A**. **⚠ Avoid using duct tape which leaves behind unwanted residue**



FIGURE 7-A

- 4) Place the included filling funnel over the top of the tank as shown in **Figure 7-B** and prepare to fill the tank. If your softener system came with **gravel**, please pour this into the tank **first**, then pour in the included resin media afterwards



FIGURE 7-B

3 › INSTALLING THE FLECK 5800 SXT VALVE

- 1) Remove the filling funnel and tape and while using the included silicone lubricant packet, lubricate the inner and outer o-rings on the bottom of the Fleck 5800 SXT Meter Valve as shown in Figures 7-C and 7-D



FIGURE 7-C



FIGURE 7-D

- 2) Next, install the **top screen (standard OR fine mesh)** to the bottom of the Fleck 5800 SXT Meter Valve as seen in Figure 7-E and then place the valve onto the top of the tank, being sure that the riser tube fits into the central o-ring on the valve, as shown in Figure 7-F. **Hand-tighten** the valve to the tank. **Do not use Teflon tape or pipe dope on the valve or tank threading**



FIGURE 7-E



FIGURE 7-F

- 3) Locate the plumbing adapter that was shipped with your system and disassemble the plumbing adaptor clips as shown in Figure 8-A



FIGURE 8-A

- 4) Using the included silicone lubricant packet, lubricate the o-rings on the Fleck 5800 SXT Meter Valve as shown in Figure 8-B

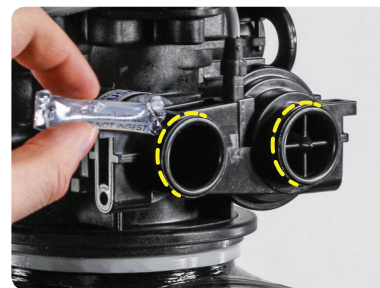

FIGURE 8-B

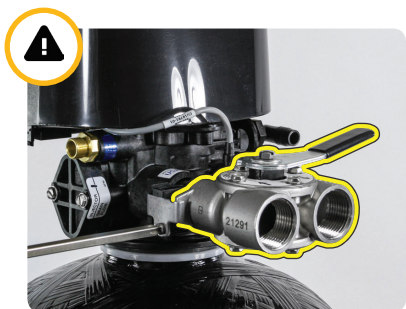

FIGURE 8-C

- 5) Finally, assemble the plumbing adaptor to the valve as shown in Figure 8-C (your bypass/ plumbing adapter model may vary). When assembling the clips back onto the valve, leave the first clip loose, tighten the second clip, and complete the assembly by tightening the first clip. **⚠ Please lightly tighten the screws into the meter as overtightening will easily cause cracking**

4 › PLUMBING YOUR FLECK 5800 SXT VALVE

- 1) Before beginning your installation, please first familiarize yourself with the IN and OUT ports on the Fleck 5800 SXT Meter Valve. **⚠ In order to prevent damage to your home and to the softener system, install the softener according to the IN and OUT arrows on the softener valve**
- 2) Locate the main shut-off valve for your house and turn it to the OFF position. If you have a private well, this valve should be near your well pressure tank. If you have a city water supply, your valve should be near your water meter
- 3) Depressurize and drain your home of water by turning on all faucets and fixtures in your home, including those outside
- 4) Pick your installation point and cut a section of pipe out to run to and from your softener. **In most cases it is preferred to keep outside lines UNSOFTENED. If you wish to keep your outside lines unsoftened, you must plumb BYPASS lines to run hard water to these fixtures**
- 5) Using soldered copper, PVC plastic pipe, or flexible connections, plumb the system according to all local plumbing codes. **If using copper pipe, please pre-fabricate at least a 12" section of pipe for the IN and OUT bound lines and use a wet rag on the lines being soldered to prevent heat damage during soldering**
- 6) Once all connections have been made, place the system into bypass by either using your existing 3-valve bypass (if ordered with a YOKE adaptor), or by switching your included bypass ON (if ordered with a bypass)
- 7) Next, gradually open your main valve and allow all air in your plumbing lines to escape slowly. Also, you may turn off all outside and inside faucets and fixtures
- 8) Check for leaks at your plumbing site for signs of slow drips and rectify if necessary. **Please do NOT take the softener out of BYPASS as the installation is not completed yet. Please take this opportunity to check and re-check the IN and OUT ports to make sure they are correct**

5 MAKING THE BRINE TANK CONNECTION

- 1) Attach the brine nut, tapered ferrule, metal tube insert, and brine line screen to one end of the included brine tubing as shown in Figure 9-A. **⚠ Be sure to face the tapered side of the ferrule towards the end of the brine line**
- 2) Next, connect this prepared end of the tubing to the Fleck 5800 SXT Meter Valve as shown in Figure 9-B. Tighten the nut to the valve using a wrench until snugly in place. Be careful not to over tighten, as you may sever the brine line

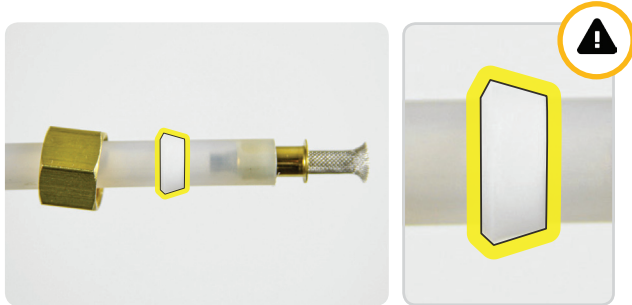

FIGURE 9-A



FIGURE 9-B

- 3) Locate the brine well and remove the cap. **You may also take this moment to prepare and insert the brine support grid determined from pages 4 and 5.** Then pull the **474 Brine Float Assembly** out of the brine well as shown in Figure 9-C
- 4) Next, fix the 474 Brine Float Assembly to the brine well through the pre-drilled hole and hand-tighten as shown in Figure 9-D



FIGURE 9-C

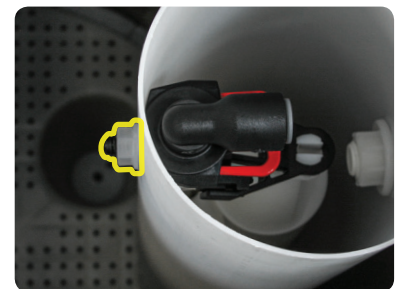

FIGURE 9-D

- 5) Take the other end of your brine line tube, make sure this end is clean cut, recut if it is not clean, mark 3/4" from the end of the tube, and insert the tube through the small hole drilled through the brine tank and brine well (Figure 9-E)
- 6) Firmly insert the tubing end 3/4" into the tube opening on the 474 Brine Float Assembly as shown in Figure 9-F. **⚠ Make sure the tube is fully inserted into the assembly**



FIGURE 9-E

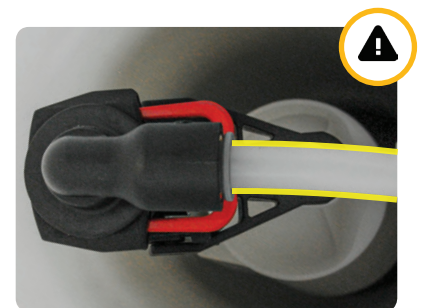

FIGURE 9-F

- 7) If you ever need to remove the tube, evenly press on both sides of the grey ring surrounding the tube and pull out as shown in Figure 10-A. ⚠ **Be sure to recut the end of the tube each time you remove it to ensure a proper seal when the tube is inserted**

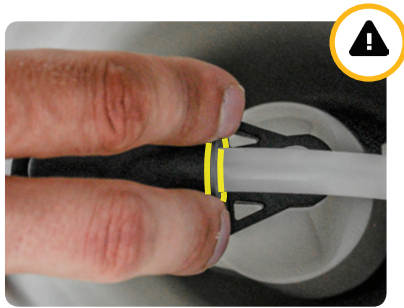

FIGURE 10-A

- 8) Finally, use 1/2" inner diameter (I.D.) tubing to connect the drain barb fitting on the brine tank to a floor drain as shown in Figure 10-B. Note that this is not necessary as the 474 assembly is designed to prevent an overflow from occurring, but it is a good precaution

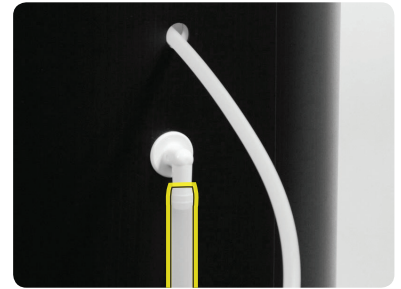

FIGURE 10-B

6 › DRAIN CONNECTION

- 1) Locate the barbed fitting and use Teflon tape to wrap the threading as shown in Figure 11-A. **Be careful to wrap the tape clockwise with the threading towards you.** Attach the barbed fitting to the DLFC fitting and ⚠ **Please use caution not to over tighten the barbed fitting**
- 2) Move to the rear of the Fleck 5800 SXT control valve, find the drain fitting pin and remove it to allow you to insert the DLFC/barbed drain fitting as seen in Figure 11-B



FIGURE 11-A

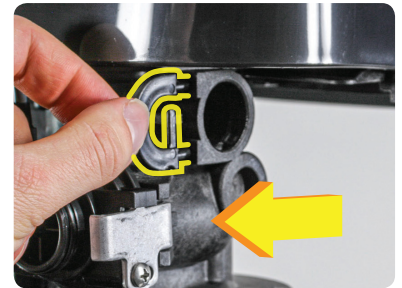

FIGURE 11-B

- 3) Insert the DLFC/Barbed fitting as seen in Figure 11-C. **Be sure that the fitting is fully inserted into the drain port by clicking it into place**
- 4) Reinsert the drain fitting pin to lock the DLFC/barbed drain fitting into the Fleck 5800 SXT control valve as seen in Figure 11-D

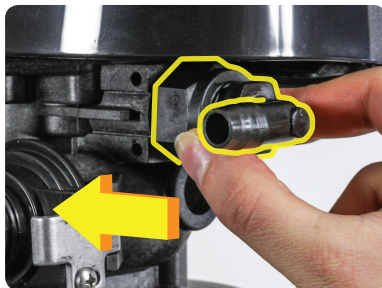

FIGURE 11-C

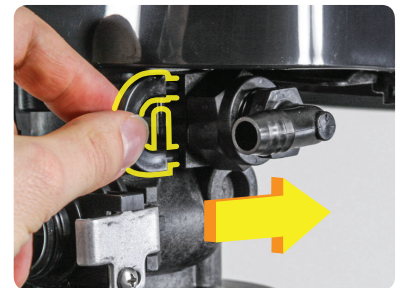

FIGURE 11-D

- 5) Next, assemble your 1/2" I.D. drain line to the drain barb as shown in Figure 11-E. **Be sure to use rigid wall 1/2" I.D. tubing that will not flatten.** Wrap electrical tape over the drain tubing to prevent a tube split and clamp the tubing securely into place with the included blue clamp as shown in Figure 11-F
- 6) Connect the other end of this drain line tubing securely to a standpipe or drain in accordance with all local plumbing codes. **Be sure that the drain line is securely in place before putting your softener in service. During regeneration, there will be increased flow via this tubing which may cause the tubing to become loose**

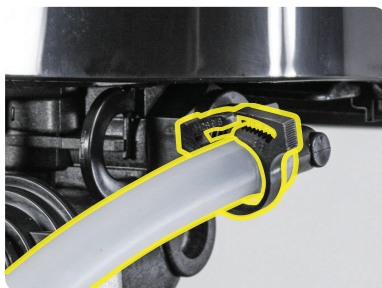

FIGURE 11-E



FIGURE 11-F

7 › PROGRAMMING THE FLECK 5800 SXT VALVE

- 1) To begin programming, first plug in your 5800 SXT Valve to a nearby wall outlet. The power port is located on the right side of the valve in front of the brine port (12-A). The system will illuminate 4 digits. The system will show the time of day and the amount of gallons remaining before the next regeneration. This display will switch between these values about every 10 seconds
- 2) Set the time on the system to 12:01 PM by pressing either the UP or DOWN button as shown in Figure. **⚠ Be careful to confirm the presence of the PM symbol in the top right corner.** You may hold the button to allow the time to scroll faster. Once the time display is set to 12:01 PM, press the REGEN button once as shown in Figure 12-B

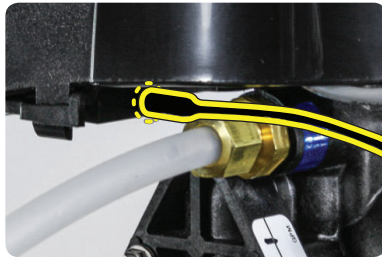

FIGURE 12-A



FIGURE 12-B

- 3) To enter MASTER PROGRAMMING MODE, press the UP and DOWN buttons TOGETHER and HOLD both for 5 seconds as shown in Figure 12-C
- 4) The display should now show **DF / GAL** as shown in Figure 12-D. This indicates U.S. Operational Mode measuring consumption in gallons. **Do not change this value and press the REGEN button once to advance to the next setting**



FIGURE 12-C



FIGURE 12-D

- 5) The display should now show **VT / 5800** as shown in Figure 12-E. This indicates Valve Type 5800 Mode. Do not change this value and press the REGEN button to advance to the next setting
- 6) The display should now show **RF / dF1b** as shown in Figure 12-F. This indicates Regeneration Flow Downflow Single Backwash. Do not change this value and press the REGEN button to advance to the next setting



FIGURE 12-E



FIGURE 12-F

- 7) The display should now show **CT / Fd** as shown in Figure 13-A. This indicates Control Type Meter Delayed Mode. Do not change this value and press the REGEN button to advance to the next setting



FIGURE 13-A

- 8) The display should now show **C / 32.0**. This indicates the Capacity is 32,000 grains. **Use the UP or DOWN button to change this value to the one listed on page 2/calculated on pages 4 and 5** and press the REGEN button as shown in Figure 13-B



FIGURE 13-B

- 9) The display should now show **H / 20**. This indicates the Hardness is 20 gpg. **Use the UP or DOWN button to change this value to the total hardness level of your water listed on page 2/calculated on page 4** and press the REGEN button as shown in Figure 13-C



FIGURE 13-C

- 10) The display should now show **RS / SF** as shown in Figure 13-D. This indicates that the Reserve Selection is Safety Factor percentage. Do not change this value and press the REGEN button to advance to the next setting



FIGURE 13-D

- 11) The display should now show **SF / 10**. This indicates the Safety Factor is 10%. This means the system will leave 10% of the softening capacity for the day before regeneration. **Use the UP button to change the value to 15 %** and press the REGEN button as shown in Figure 13-E



FIGURE 13-E

- 12) The display should now show **DO / 14** as shown in Figure 13-F. This indicates the Day Override is 14 days; the system will regenerate in 14 days if the meter has not measured water consumption to have reached the calculated capacity. Do not change this value and press the REGEN button



FIGURE 13-F

- 13) The display should now show **RT / 2:00** as shown in Figure 14-A. This indicates the system will regenerate at 2:00 AM following the day the water consumption has passed the calculated capacity. If you prefer an alternate regeneration time, please enter it here and then press the REGEN button to advance



FIGURE 14-A

- 14) The display should now show **BW / 10** as shown in Figure 14-B. This indicates Backwash time is 10 minutes long. Do not change this value and press the REGEN button to advance to the next setting



FIGURE 14-B

- 15) The display should show **BD / 60** as shown in Figure 14-C. This indicates Brine Draw time is 60 minutes long. Do not change this value and press the REGEN button to advance to the next setting



FIGURE 14-C

- 16) The display may now show **RR / 12** as shown in Figure 14-D. This indicates Rapid Rinse time is 12 minutes long. Do not change this value and press the REGEN button to advance to the next setting



FIGURE 14-D

- 17) The display may now show **BF / 10**. This indicates the length of the Brine Fill cycle during regeneration. **⚠ Use the value listed on page 2/ calculated on pages 4 and 5** and then use the UP or DOWN button to adjust this. Then press REGEN as shown in Figure 14-E



FIGURE 14-E

- 18) The display may now show **FM / t0.7** as shown in Figure 14-F. This indicates Flow Meter type 3/4" Turbine. Set the setting to t0.7 if you have the 3/4" turbine meter or P0.7 for the 3/4" paddle wheel meter. Press the REGEN button to advance to the home screen



FIGURE 14-F

19) The display may now show **RE / OFF** as shown in Figure 15-A. This indicates Time Relay Off. Do not change this value and advance



FIGURE 15-A

20) The display may now show **VR / OFF** as shown in Figure 15-B. This indicates Flow Relay Off. Do not change this value and advance



FIGURE 15-B



FIGURE 15-C

21) The system will now exit Master Programming mode and the display should now show the time of day followed by the number of gallons remaining as shown in Figure 15-C. Now change the time of day to your current time with either the UP or DOWN button. **Be careful to note the presence or absence of the PM indicator in the top right corner.** Confirm the time with the REGEN button

8 › INITIAL START-UP

- 1) With one nearby softened faucet running in the COLD position, slowly open your bypass valve or 3-valve bypass to about $\frac{1}{4}$ open to allow the air trapped in the softener to escape via your running faucet.
NOTE: Opening the bypass too quickly or too open may damage your softener or plumbing
- 2) Allow the softener tank to slowly fill with water. After a few minutes, you will see a trickle of water coming from the cold water faucet. Allow the water to run slowly in this manner for an additional 5 minutes. Next, with the cold water faucet still running, gradually move your bypass valve to the fully open position.
NOTE: You may see some initial discoloration from the softened water – this is normal and should dissipate within the first 40-50 gallons of water used. Turn off the running cold water faucet when the water runs clear
- 3) **⚠ To test the integrity of your new system and all connections, it is strongly encouraged that you perform a short form regeneration to check for leaks before service.** Begin this process by adding approximately 5 gallons of water/the amount of water needed to cover the brine grid into the brine tank. Start the regeneration sequence by HOLDING the REGEN button for 5 seconds. Once the screen stops flashing BW, let BW - Backwash run for about 1 minute to observe the water leave out the drain line and check for leaks. If you notice any leaks, **return to page 11** to review preparing the drain connection. Click the REGEN button ONCE to move on to BD - Brine Draw
- 4) Once the screen stops flashing BD, let BD - Brine Draw run for about 1 minute to observe the water level in the brine tank being drawn lower. Also check the brine line and the float valve in the brine well for leaks. If the water level doesn't lower or there is a leak, **return to pages 9 and 10** to review preparing the brine tank connection. Click the REGEN button ONCE to move on to RR - Rapid Rinse
- 5) Once the screen stops flashing RR, advance from RR - Rapid Rinse to BF - Brine Fill by clicking the REGEN button ONCE more. Once the screen stops flashing BF, let BF - Brine Fill run for about 1 minute to observe the water level in the brine tank rise. Also check the brine line and float valve in the brine well for leaks. If the water level doesn't rise or there is a leak, **return to pages 9 and 10** to review preparing the brine tank connection. Click the REGEN button ONCE to finish
- 6) Now you may add 120-160 pounds of pellet, solar, or block salt to your brine tank. **Always keep your brine tank filled with salt to at least above the water level.** You do not need to perform a regeneration immediately after installation as the new resin arrives at full softening capacity. Simply let your softener meter automatically trigger regenerations by tracking the water consumption

› CONGRATULATIONS

Your new softener with Fleck 5800 SXT Meter Valve is now properly installed and programmed! Please maintain your system by keeping the softener plugged-in and always keep your brine tank filled with salt to at least above the water level. We appreciate your business, and hope that you enjoy years of trouble-free softened water!