



Performa Valve Specifications

263 and 268 Configurations



Specifications

Flow Rates (Valve Only) – Logix and 900 Series Controllers

Service @ 15 psi (1.03 bar) drop	25.0 gpm (5.7 m ³ /h)
Backwash @ 25 psi (1.72 bar) drop	20.0 gpm (4.5 m ³ /h)
Service	Cv = 6.50 (Kv = 5.6)
Backwash	Cv = 4.00 (Kv = 3.5)

Flow Rates (Valve Only) – 400 Series Controllers

Service @ 15 psi (1.03 bar) drop	25.0 gpm (94.6 Lpm)
Backwash (Softener) @ 25 psi (1.72 bar) drop	13.3 gpm (50.4 Lpm)
Service	Cv = 6.50 (Kv = 5.6)
Backwash Softener	Cv = 2.68 (Kv = 2.30)

Valve Connections/Dimensions

Tank Thread	2-1/2-inches – 8, male
Inlet/Outlet Threads	1-3/4-inches – 12 UNC-2A male
Drain Line	3/4-inch NPT, male
Brine Line	3/8-inch NPT, male
Distributor Tube Diameter	1.050-inches (27 mm)
Distributor Tube Length	1/2 ± 1/2-inches (13 ± 13 mm) above top of tank

Design Specifications/Ratings

Valve Body	Glass-filled Noryl® – NSF listed material
Rubber Components	Compounded for cold water – NSF listed material
Valve Materials Certification	NSF/ANSI 44 rated component for material safety
Weight (Valve with Control)	5.34 lbs (2.42 kg)
Recommended Operating Pressure	20 - 120 psi (1.38 - 8.27 bar)
Canada	20 - 100 psi (1.38 - 6.89 bar)
Hydrostatic Test Pressure	300 psi (20.69 bar)
Water Temperature	35° - 100°F (2° - 38°C)
Ambient Temperature*	35° - 120°F (2° - 48.9°C)

*Recommended use of outdoor cover for direct sunlight applications.

Options

Turbine for Demand Systems	Internal standard Autotrol 1-inch (25 mm) turbine
Bypass Valve, Model 1265	Noryl®, 1-inch flow path

Bypass Fitting Kits:

Copper, Sweat Tube Adapter	1-1/4-inches, 1-inch or 3/4-inch (32 mm, 25 mm or 19 mm)
CPVC, Solvent Weld Tube Adapter	1-inch or 3/4-inch (25 mm or 19 mm)
Plastic NPT Pipe Adapter	1-inch male or 3/4-inch male (25 mm or 19 mm)
Plastic BSPT Pipe Adapter	1-inch male or 3/4-inch male (25 mm or 19 mm)
Brass NPT Pipe Adapter	1-inch male or 3/4-inch male (25 mm or 19 mm)
Brass BSPT Pipe Adapter	1-inch male or 3/4-inch male (25 mm or 19 mm)
Brine Refill Controls	.17 gpm (.64 Lpm) fixed; .33 gpm (1.25 Lpm) fixed; .77 gpm (2.91 Lpm) fixed

Compatible with Regenerants/Chemicals	Sodium chloride, potassium chloride, potassium permanganate, sodium bisulfite†, sodium hydroxide†, hydrochloric acid†, chlorine†† and chloramines††
---------------------------------------	---

† See owners manual for specific concentrations.

††Valve for use on potable water supply.

Injector* Performance – Logix Series Controllers

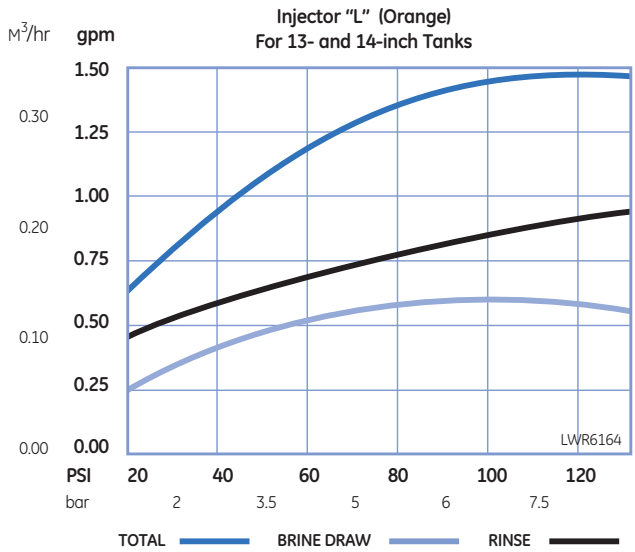
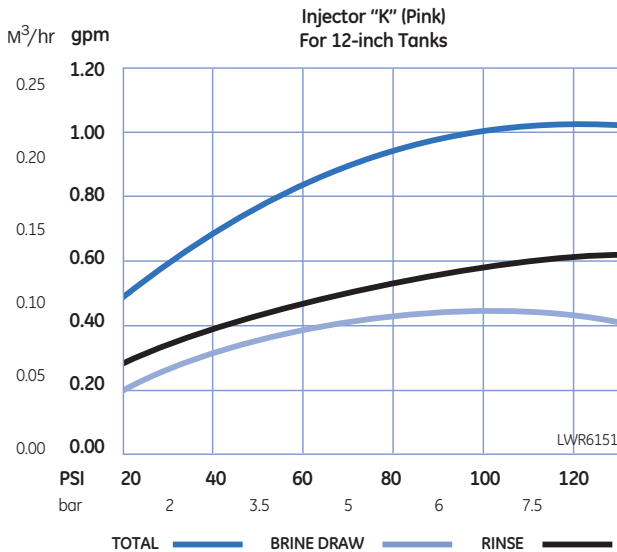
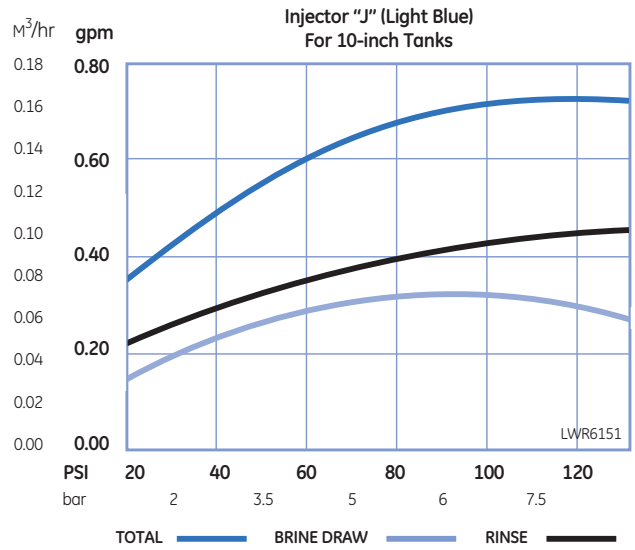
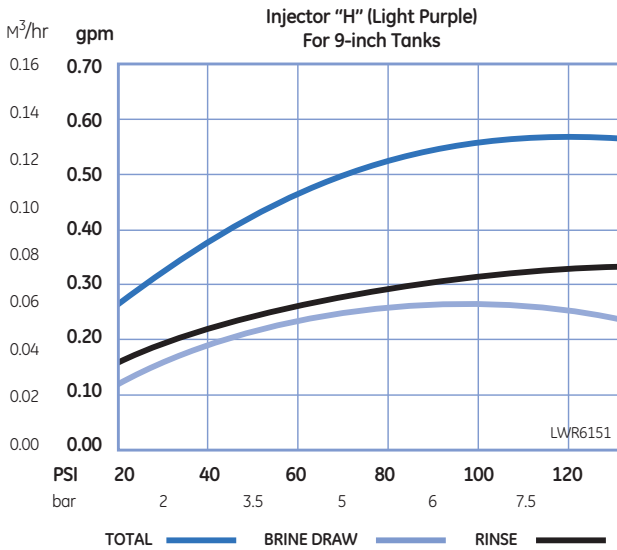
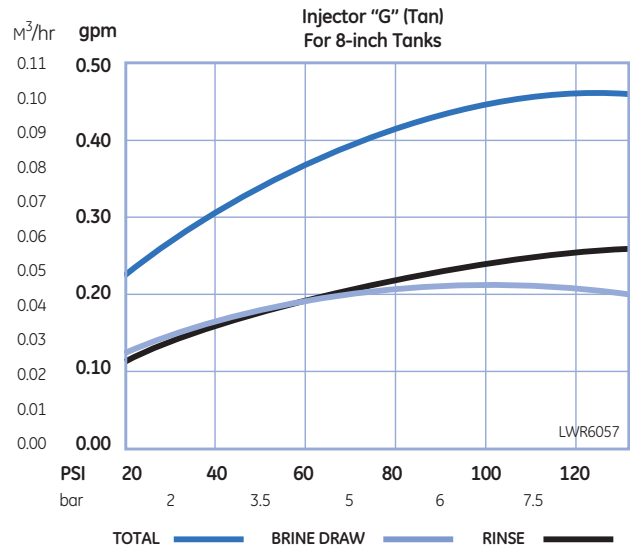
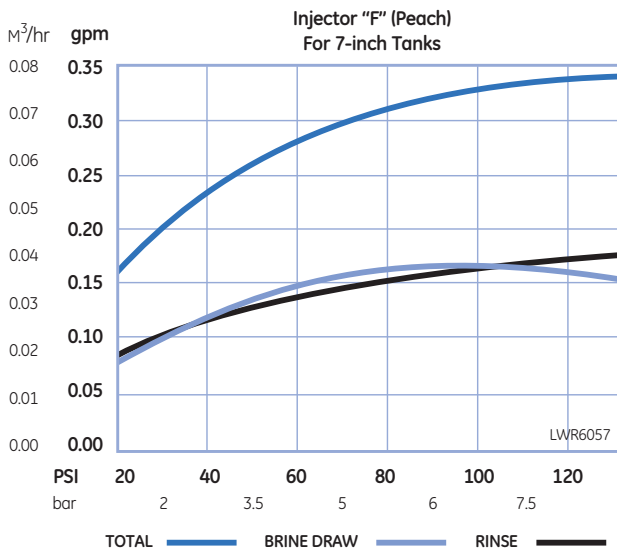

*New injectors for high-efficiency regeneration sequence are standard with Logix Controllers.

NOTE: Actual injector performance is dependent on the resin used, tank geometry, elevated drain, etc. This injector data was taken using an empty tank (no resin).



400 and 900 Series Controllers

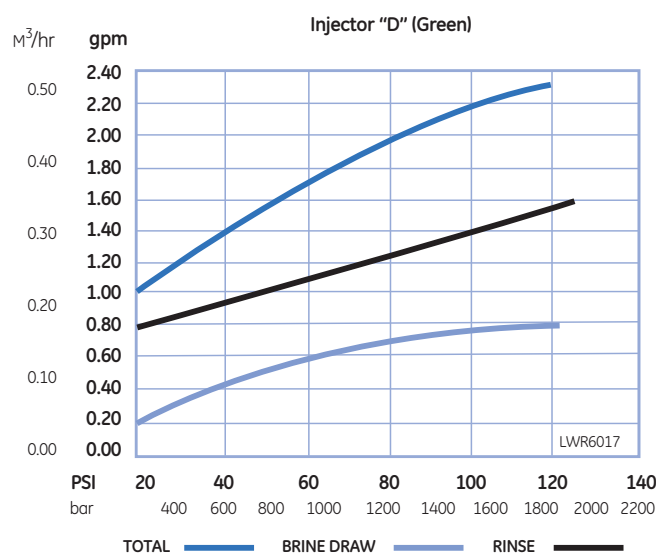
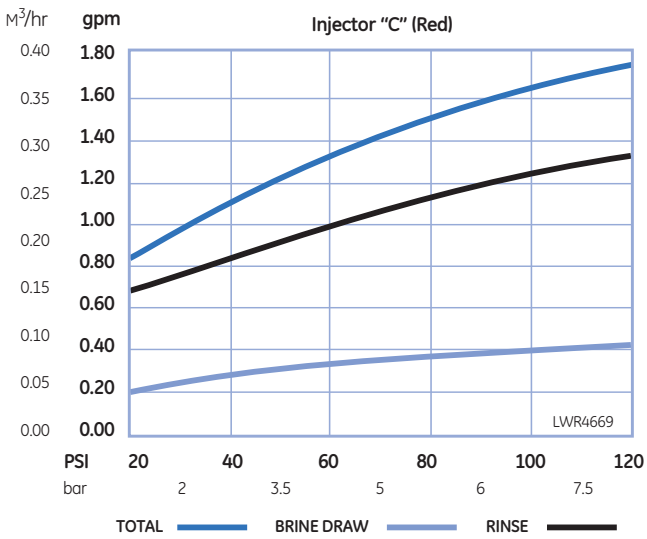
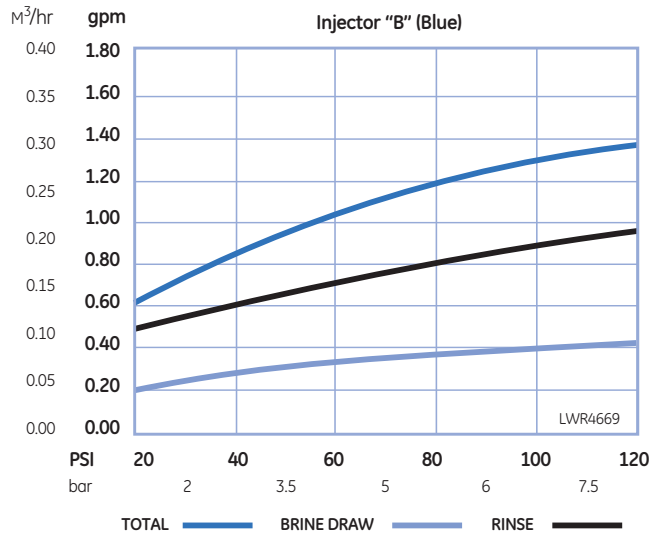
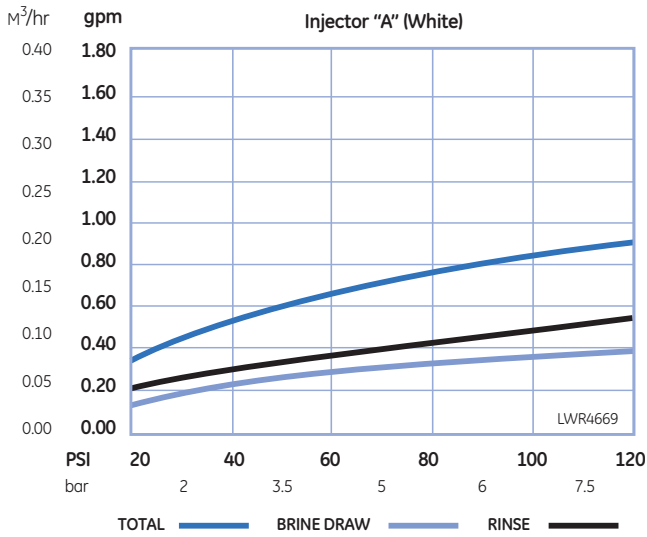

Valve Flow Rate Characteristics

Logix and 900 Series Controllers

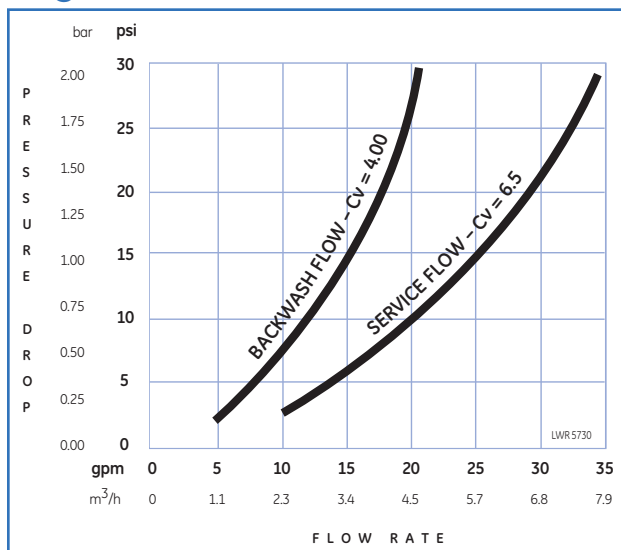

400 Series Controllers

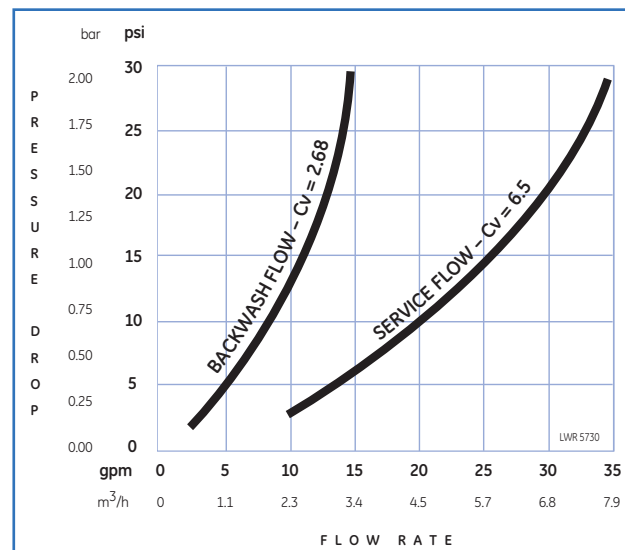

Controller Series

GE offers a full range of valve controllers to meet all residential water-conditioning applications.

Logix Series

740 Time Clock

- Simple, economic electronic time clock (chronometric)
- 7- or 99-day regeneration setting
- High efficiency regeneration sequence
- 12-volt operation
- Filter or conditioner setting in one control
- Operates 255, 263, 268 with one controller



760 Demand

- Simple, economic electronic demand (volumetric)
- Calendar override
- 12-volt operation
- 28-day variable reserve
- High efficiency regeneration sequence
- Automatic capacity calculations
- Operates 255, 263, 268 with one controller



742 Time Clock

Same features as the 740 time clock, plus:

- Fully programmable cycle times
- Salt setting in 1-pound increments
- Optional no-salt detector
- Operates 255, 263, 268, 278, and Magnum IT with one controller

762 Demand

Same features as the 760, plus:

- Fully programmable cycle times
- Salt setting in 1-pound increments
- Optional no-salt detector
- Operates 255, 263, 268, 278, and Magnum IT with one controller

400 Series

440i Time Clock

- Value priced, reliable mechanical control
- Time-clock regeneration
- Set it and forget it
- 12-volt or 120-volt versions available
- 6- or 7-day regeneration
- Operates 255, 263, 268 valves



460i Time Clock

- Economical electronic-demand control
- Simple set-up and programming
- Calendar override
- 12-volt operation
- 7-day variable reserve
- Operates 255, 268 valves









Electrical Specifications

Controller Operating Voltage	12 Volt – AC (Requires use of GE Infrastructure supplied transformer)
Input Supply Frequency	50 or 60 Hz (Controller configuration dependent)
Motor Input Voltage	12 Volt – AC
Electronics Operating Voltage (Logix Series)	3.5 Volt – AC
Controller System Power Consumption	3 Watts average

Transformer Specifications – All Controllers

All Controllers require the use of a GE Infrastructure supplied transformer.

Transformer Output Voltage	12 Volt – AC 400mA
Transformer Input Options	115 Volt – AC 50/60 Hz; 230 Volt – AC 50/60 Hz; 100 Volt – AC 50/60 Hz
Transformer Plug Options	Indoor North American Plug 
	Outdoor North American (UL Listed for outdoor use) 
	Japanese Plug 
	Taiwan/Korea Plug 
	Australian Plug 
	United Kingdom Plug 
	Mainland Europe Plug 
	Additional transformers may be available – call for more information

Controller valve manufactured by:

North American Sales
5730 N. Glen Park Road
Milwaukee, WI
53209-4403
USA
(262) 238-4400 Phone
(262) 238-4402 Fax

For More Information:
Call GE Infrastructure
Water & Process Technologies;
Household Water Group at
(262) 238-4400 or
(800) 279-9404,
or visit www.gewater.com/equipment/valve/index.jsp

Backwash Flow Control Table

Backwash Number**	Flow Rate (gpm)	Flow Rate (Lpm)	Backwash Number**	Flow Rate (gpm)	Flow Rate (Lpm)
7	1.3	4.9	12	3.9	14.7
8	1.7	6.4	13	4.5	17.0
9	2.2	8.3	14	5.3	20.0
10	2.7	10.2			

**Backwash flow controls sized for 5.0 gpm/ft².

Perma Valve Outline Dimensions

Logix Series Controllers

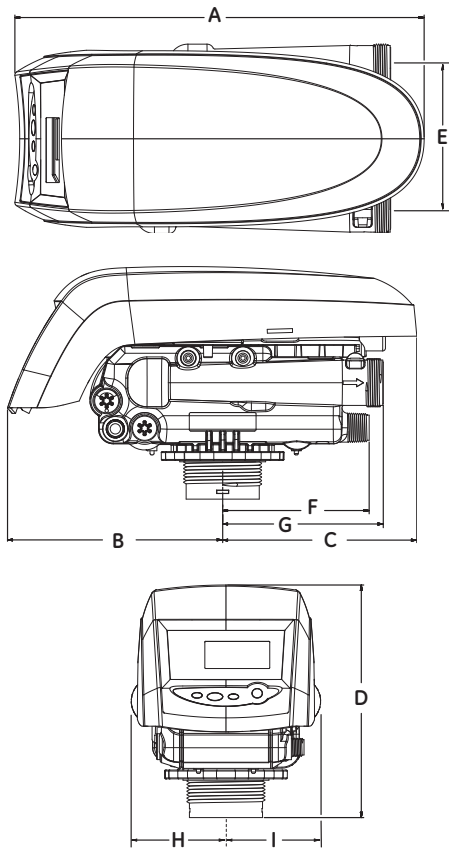

400 Series Controllers

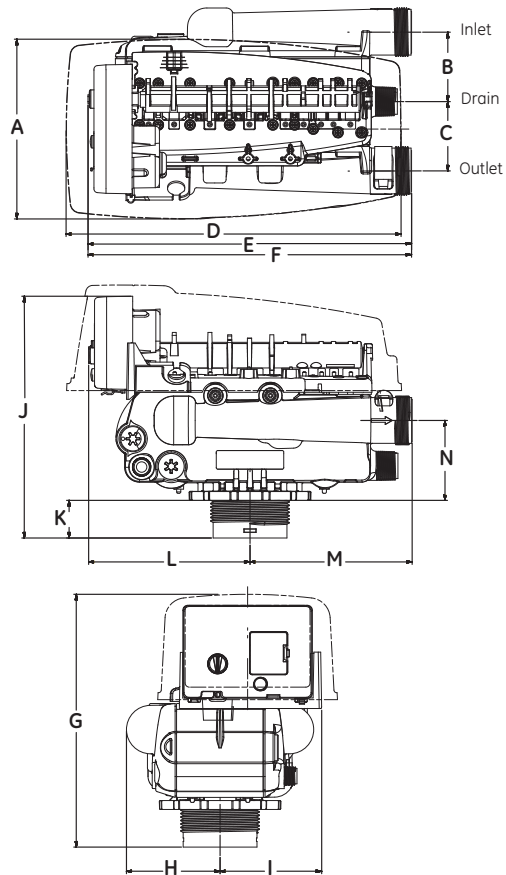

Perma Valve – Logix Series Controller

	in	cm		in	cm
A	14.89	(39)	F	5.33	(13.5)
B	7.83	(20)	G	5.84	(15)
C	7.06	(18)	H	3.44	(9)
D	8.46	(21.5)	I	3.44	(9)
E	5.00	(12.5)			

Perma Valve – 400 Series Controller

	in	cm		in	cm		in	cm
A	6.48	(16.5)	F	11.66	(29.6)	K	1.36	(3.4)
B	2.50	(6.3)	G	9.11	(23.1)	L	5.82	(14.8)
C	2.50	(6.3)	H	3.37	(8.6)	M	5.82	(14.8)
D	12.07	(30.7)	I	3.66	(9.3)	N	2.88	(7.3)
E	11.66	(29.6)	J	8.71	(22.1)			

