

Supreme®

**SAVE THESE
INSTRUCTIONS**

HY-Drive Pump

CARE AND OPERATING INSTRUCTIONS

MODELS	ITEM#
WFP1600	02583
WFP2100	02582
WFP2600	02581
WFP3200	02580
WFP4000	02575
WFP4800	02570
WFP6000	02572

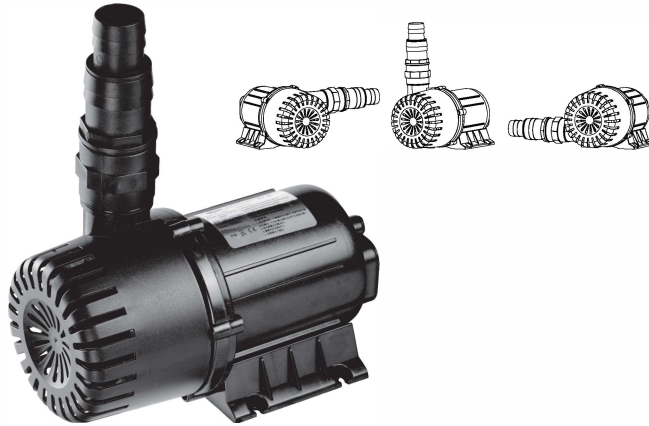

Subscribe to our YouTube Channel and view all of our product videos.

WARNING! PONDS ARE DANGEROUS TO SMALL CHILDREN!
NEVER LEAVE CHILDREN UNSUPERVISED NEAR A POND.

Thank you for purchasing this Supreme product. This continuous duty pump is designed to move large volumes of water silently and efficiently through filtration systems or to a waterfall, stream or fountain. It incorporates a high efficiency vortex impeller in conjunction with a ceramic impeller shaft and bearings to provide energy savings while maintaining high output.

This pump can be used submersed or inline, indoors or outdoors. Note that when used inline it should be placed below the water level since it is not self-priming. Never run this pump dry.

Rotor assembly is removable for simple cleaning maintenance. The unique design reduces the frequency of pump cleaning while maintaining optimum water flow. Overload protection is built in by means of a self resetting thermal overload switch.



ELECTRICAL PRECAUTIONS

Always use a properly grounded outlet. Do not immerse the plug in water. **DO NOT REACH INTO THE WATER TO REMOVE THE PLUG. TURN OFF CIRCUIT FIRST.** A "drip loop" in the cords should be used. A "drip loop" is a loop in the cord below the level of the receptacle or plug that prevents water from traveling along the cord. The national Electric Code requires that a ground fault interrupter circuit (GFCI) be installed in every branch circuit supplying the fountain or pond equipment. Your dealer can supply GFCI units. **NEVER REMOVE GROUND PIN FROM PLUG.**

WARNING: FOR YOUR PROTECTION, ALWAYS UNPLUG THE UNIT FROM ITS POWER SOURCE BEFORE INSTALLING OR SERVICING PUMP OR WHEN CARRYING OUT POND MAINTENANCE. DO NOT REACH, REMOVE OR DISASSEMBLE BEFORE YOU DISCONNECT POWER.

OPERATION PRECAUTIONS

Never run pump dry. Only use this pump with clean water. It is not intended to move water containing large non-dissolved solids. Never use pump for liquids other than water. Never pull the pump from a pond by pulling the power cord. Never remove the plug or shorten the power cord. Keep the connectors (Plug and Socket) dry. The pump is not suitable for use in swimming pools, swimming ponds and other situations where persons could make bodily contact with the water.

NEVER ALLOW STANDING WATER TO FREEZE IN PUMP OR CONNECTIONS.

Operation Instructions

Attach hoses using Teflon tape on fittings. This will aid in future disassembly.

Make certain that all electrical connections have a GFCI installed.

If pump is to be installed submersed, use a separate pump bag or skimmer to help protect the intake from leaves and other debris getting drawn into the impeller. To avoid pulling air into the pump, it should be submerged at least 6 inches (15cm) below the water surface.

If pump is used inline, place it a minimum of 6 inches (15CM) below water level otherwise it will be necessary to prime it. A separate in-line check valve is strongly recommended to prevent loss of prime if power is interrupted.

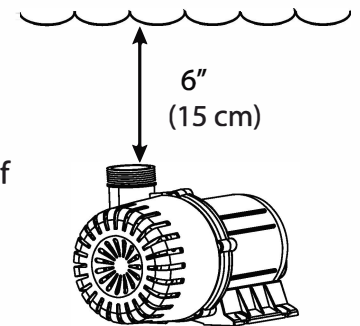

MAINTENANCE & CLEANING

This pump does not require any lubrication or special maintenance. Periodically cleaning the impeller will maintain pump performance and extend pump life.

- Completely disconnect pump from power supply.
- Remove hoses and bring pump to clear work area.
- Pull intake strainer with strainer adapter off.
- Remove screws to detach impeller housing. Be careful not to lose nuts in motor housing recesses.
- Pull the impeller out from the chamber.
- Clean impeller with fresh water only, never any solvents.
- Reverse steps to reassemble. If rubber seal became detached, press it back into the track on the motor housing. Pay careful attention to align openings on impeller assembly plate with molded pins on motor housing.

PUMPGUARD™ maintenance INSTRUCTIONS

- 1) DISCONNECT POWER TO PUMP.
- 2) REMOVE PUMP FROM WATER.
- 3) POSITION PUMP WITH VOLUTE INLET FACING UPWARDS.
- 4) POUR PUMPGUARD INTO VOLUTE INLET UNTIL FULL.
- 5) ALLOW TO SOAK FOR 2 TO 3 MINUTES.
- 6) THOROUGHLY RINSE WITH CLEAN WATER.
- 7) PLACE PUMP BACK INTO SERVICE.

PUMPGUARD™ is available in three sizes:
 4 oz. - Impeller /Volute treatment --- ITEM # 03905
 32 oz. - Soak/Dunk impeller treatment -ITEM # 03907
 128 oz. - Commercial Size ----- ITEM # 03909

WINTERIZATION: Do not allow standing water to freeze in pump.

Supreme® HY-Drive PARTS LIST

NOTE: Parts vary for different models.
 Write your Model and Item number here for reference.

MODEL :

ITEM #

#	Description
1	Outlet
2	O-ring
3	Outlet Connector
4	O-ring
5	Outlet Connector
6	O-ring
7	Intake
8	Intake Strainer
9	Strainer Adapter
10	Stainless Steel Screws
11	Motor Cover
12	Impeller
13	Large O-ring
14	Motor
15	Pump Base

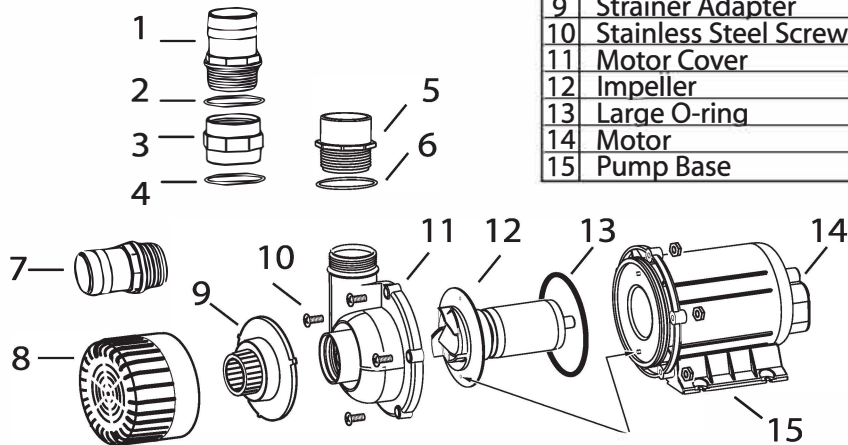

Align holes with pins

HY-DRIVE MODEL	ITEM #	OUTLET SIZE	NOMINAL	AMPS	WATTS	GALLONS PER HOUR										SHUTOFF
						AT 0'	AT 1'	AT 3'	AT 5'	AT 7'	AT 10'	AT 15'	AT 20'	AT 25'		
1600	02583	1"	1600	1.0 A	120	1750	1700	1575	1400	1250	1000	375	-	-	17'	
2100	02582	1"	2100	1.5 A	190	2125	2075	1900	1750	1600	1300	850	300	-	22.5'	
2600	02581	1"	2600	2.2 A	270	2700	2550	2525	2450	2225	1975	1625	1250	300	26.5'	
3200	02580	1 1/2"	3200	1.6 A	200	3500	3300	2700	2050	1650	650	-	-	-	12'	
4000	02575	1 1/2"	4000	1.9 A	230	4300	4000	3300	2700	2350	1475	-	-	-	13'	
4800	02570	1 1/2"	4800	2.0 A	250	5100	5000	4500	3900	3150	2350	800	-	-	18.5'	
6000	02572	2"	6000	5.5 A	675	5700	5500	5100	4700	4200	3400	2450	1150	-	22.5'	

LIMITED WARRANTY

E.G. Danner Mfg. Inc. will repair or replace any unit found to be defective within three years of original purchase. Cutting or altering cord removing or defacing product labels voids any warranty consideration. For warranty repair return only the part that is defective to our factory. Please include a dated proof of purchase and \$20.00 for postage and handling. Damages or injuries resulting from negligence, shipping, handling, improper installation, maintenance or misuse of the product are not covered by warranty. This warranty gives you specific legal rights. You may have other rights which vary from state to state.

To validate this warranty keep your proof of purchase (Copy of sales receipt).

DANNER MFG. INC. • Islandia, New York 11749-1489 • (631) 234-5261
 Visit our web site at www.dannermfg.com