

ESF1250



Submersible Pump/Filter/UV Combo

Thank you for purchasing the EasyPro Submersible Pump/Filter/UV Combo. This compact all-in-one unit works efficiently to keep the water in your pond or water feature clear and clean. In addition to removing solids this unit provides biological filtration and includes a ultraviolet clarifier to kill free floating algae. The UV clarifier has its own plug to be used only when needed to kill floating algae. A set of nozzles is included to provide the option of a decorative fountain in your pond.

Please read this instruction booklet carefully before use to assure that you safely and correctly use this product.

Model	ESF1250
Pump	650 GPH Mag Drive
Voltage	115 Volt/60Hz
Max Flow	650 GPH
Pond Size	250-1250 Gallons
Wattage	50 Watts
Power Cables	15 feet
Fountain Nozzles	Three-tier, two-tier, waterbell
UV-C Lamp	11 Watt
Ballast	cUL listed 115V / 60Hz

Safety and Warnings:

1. Be sure to read and follow all safety instructions
2. Always disconnect the electrical supply before handling, maintaining, repairing or installing any pond equipment.
Do not immerse or attempt to use a wet plug.
3. **WARNING:** Risk of electric shock. Install unit only to a covered Class A 115 volt GFCI protected receptacle that is weatherproof with the power unit connect to the receptacle.
4. Provide a "drip loop" with the power cords by making a "loop" of cord below the power receptacle. This prevents water from traveling along the cord into the receptacle.
5. This unit has not been approved for use in swimming pools or spas.
6. Do not use if power cord is damaged. Cord is not repairable and damaged unit should be discarded.
7. The integrated pump must be fully submersed underwater at all times when operating. Never let the pump run dry, as this can damage the impeller or overheat and possibly burn out the pump.
8. Do not use to pump oil or other non-intended liquids.
9. **DANGER:** Do not operate the UV lamp outside the housing of the unit. UV radiation can be harmful to skin and eyes.



UV Installation and Maintenance



WARNING: Disconnect the unit from power source before performing any maintenance or installation on the unit.

USE A CLEAN CLOTH TO HANDLE THE UV LAMP, TOUCHING THE LAMP CAN GREATLY REDUCE ITS LIFE

Instructions for replacing and cleaning UV lamp and quartz sleeve. Periodic cleaning of the quartz sleeve may be necessary for the UV light to reach the bacteria. If the UV lamp is functional and intact, the sleeve may be replaced or cleaned with a soft cloth and reassembled. After a year of continuous use the lamp may still light but the UV effectiveness is diminished.

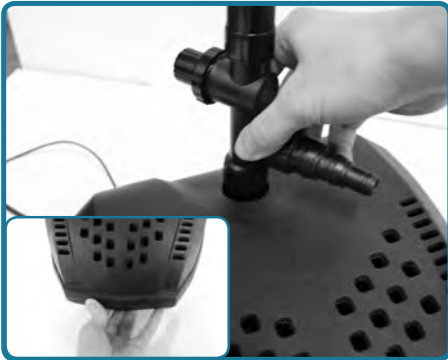

1. Unscrew fountain assembly, then remove top cover from unit.



2. Remove three Phillips screws on pump, pull pump out of base and set aside.



3. Unscrew and remove the large threaded cap on the UV housing to reveal inner UV assembly.



4. If the UV lamp is functional and intact, sleeve may be replaced or cleaned with a soft cloth and reassembled.



5. To replace lamp, unscrew threaded ring that holds the quartz sleeve in, and remove sleeve from UV assembly.

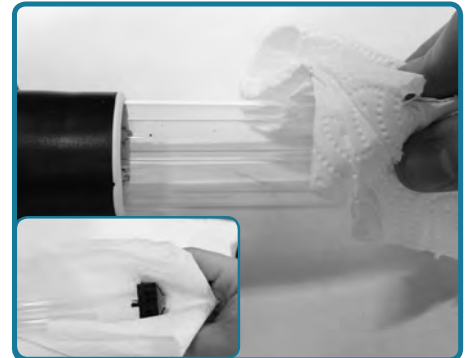

6. Remove grommet from end of the lamp and set aside, gently pull lamp out of the socket and discard.



7. Using a clean soft cloth remove the new lamp from its package and gently push the lamp into the socket. **Do not touch the UV lamp with your fingers.**



8. Replace grommet to the end of the lamp and reinsert into quartz sleeve.

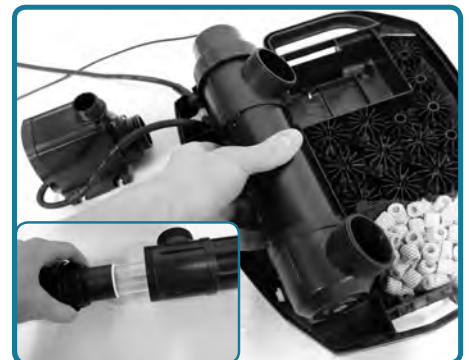

9. Reinsert UV assembly into plastic housing, tighten cap and replace everything back into base.

Installation & Operation



WARNING: Disconnect the unit from power source before performing any maintenance or installation on the unit.

1. Determine the exact place to install filter. The filter base must be completely submerged and sit on a flat level surface.
2. Choose your fountain nozzle and use diagram below to build fountain assembly and attach to pump body.
3. Level the fountain assembly using ball-joint.
4. Plug in the pump and adjust diverter valve to desired fountain spray.
5. Only operate UV unit when the pump is running.
6. If regular beneficial bacteria treatments are used in the pond, turn the UV unit off for at least 24 hours to allow treatments to be most effective.

Fountain Assembly

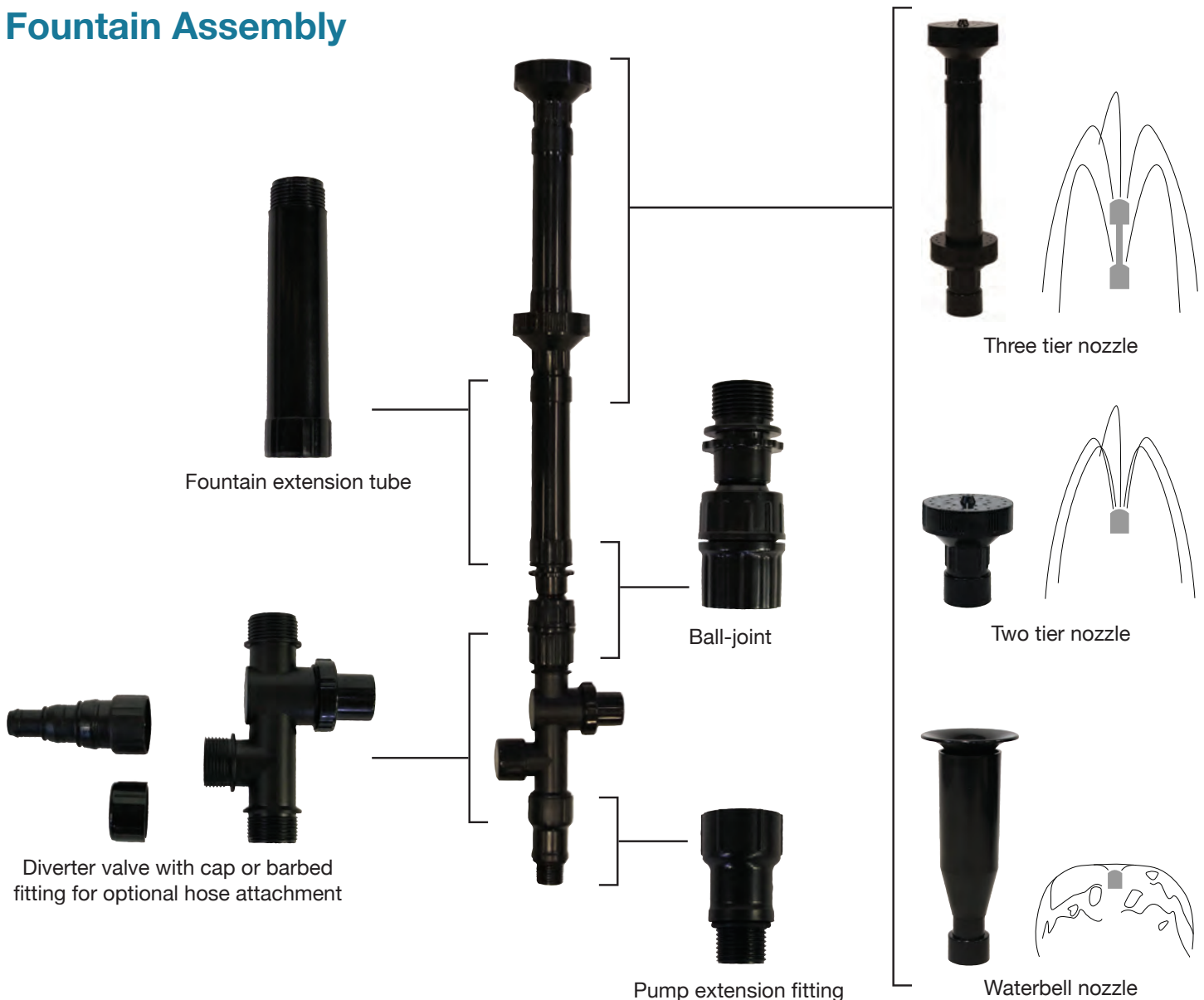

Maintenance

Refer to previous page for UV lamp and quartz sleeve replacement. Filter pads and media are wearable items that may be replaced periodically.

1. Pick up unit out of water and unscrew fountain assembly. **Do not pick up filter by power cord.**
2. Remove top cover from unit and take out filter pads and media.
3. Flush filter pads and media with water or replace.
4. Reassemble filter pads with the correct orientation and replace top cover.
5. Reattach fountain assembly and return unit to water.
6. In freezing climates be sure to remove the unit from the pond and store during the winter.

Replacement Parts

Part #	Description
ESF1250B	Ultraviolet Lamp
ESF1250S	Quartz Sleeve
ESF1250I	Pump Impeller
ESF1250F	Filter Pad & Media



EasyPro Pond Products Limited Warranty

EasyPro Pond Products ("EasyPro") warrants to the purchaser that this product ("Product") will be free from any mechanical or material defects for a period of **one year** from the date of purchase. UV lamp, quartz sleeve, pump impeller and filters are considered wearable items and are not covered under this limited warranty. This warranty only covers properly installed and maintained Products sold by authorized EasyPro Sellers who are subject to and follow EasyPro's quality control standards. Please note that because EasyPro is unable to control the quality of Products sold by unauthorized sellers, unless otherwise prohibited by law, this warranty does not cover Products purchased from unauthorized sellers.

This warranty does not cover normal wear and tear, nor any deterioration suffered through overloading, improper use, negligence, improper installation, acts of God or accident. Similarly, any modification made by the purchaser to the Product will cause the warranty to be null and void. This warranty does not cover any cost associated with the installation or removal of the Product subject to a warranty claim.

All returned items will be inspected to determine cause of failure before a warranty claim is approved.

The exclusive remedies provided hereunder shall, upon EasyPro's inspection and option, be either repair or replacement of the Product or parts covered under this warranty.

Making a Claim: A Return Authorization ("RA") number must first be obtained by calling EasyPro at 800-448-3873 or via email at warranty@easypro.com. It is the purchaser's responsibility to pay the return shipping charges. Be sure to include the RA number, original receipt (in the form of an invoice or sales receipt), your name, your return address and your phone number inside of the package. No warranty claims will be honored without the original receipt that shows that your purchase was made from an Authorized EasyPro Seller. Ensure the product is properly packaged and insured for the replacement value. Damage due to improper packaging is the responsibility of the sender.

ALL OTHER EXPRESS OR IMPLIED WARRANTIES INCLUDING MERCHANTABILITY OF FITNESS FOR A PARTICULAR PURPOSE ARE HEREBY LIMITED IN DURATION TO THE DURATION OF THE WARRANTY AS DESCRIBED ABOVE. Some States do not allow limitations on how long an implied warranty lasts, so the above limitations may not apply to you.

EasyPro shall not be held liable for any damages caused by defective components or materials of this Product; or for loss incurred because of the interruption of service; or any consequential/incidental damages and expenses arising from the production, sale, use or misuse of this Product. Some States do not allow the exclusion or limitation of incidental or consequential damages, so the above limitation or exclusion may not apply to you.

EasyPro shall not be held liable for any loss of fish, plants or any other livestock as a result of any failure or defect of this Product. This warranty gives you specific legal rights, and you may also have other rights that vary from State to State.



800-448-3873 • Grant, Michigan
www.easypro.com