



## User Manual

### Easy Electric Coffee & Spice Grinder

Model: AusGrind-E09



AUSPURE - SUPPORT

[www.auspure.com/au](http://www.auspure.com/au) | [support.au@auspure.com](mailto:support.au@auspure.com)

# Thank you

Thank you for purchasing the Coffee and Spice Grinder by Auspure Kitchen. We are committed to providing our customers with high quality products for having a reliable facilitated kitchen in their house.

Should you have any questions or concerns about using your Auspure products, feel free to contact our helpful customer support team at [support.au@auspure.com](mailto:support.au@auspure.com) We hope you enjoy using this product and we will be more than happy to assist our valued customers for any inquiry related to Auspure products.

## TABLE OF CONTENTS

---

SAFETY INSTRUCTION	4
PARTS NAME	5
GETTING TO KNOW YOUR COFFEE & SPICE GRINDER	6
BEFORE THE FIRST-TIME USE	7
GETTING STARTED	8
CLEANING AND CARE	11
STORAGE	12
DISPOSAL	12
TROUBLESHOOTING	13
WARRANTY INFORMATION	14
DEFECTIVE PRODUCT AND RETURN	17
AUSPURE CUSTOMER SUPPORT	17

## PACKAGE CONTENTS

---

- 1 × Easy Electric Coffee & Spice Grinder
- 1 × Coffee Grinder Container
- 1 × Power Cord
- 1 × User Manual
- 1 × Warranty Card

## TABLE OF SPECIFICATIONS

---

<b>Product Model</b>	AusGrind-E09
<b>Product Brand</b>	Auspure Kitchen
<b>Power Supply</b>	220-240 V~, 50/60 Hz
<b>Rated Power</b>	300 W
<b>Rotational Speed</b>	22,000 RPM
<b>Max Capacity</b>	90 gr
<b>Material</b>	Stainless Steel
<b>Safety Lock</b>	✓
<b>Detachable Container</b>	✓
<b>Thermostat</b>	✓
<b>Product Weight</b>	1.37 kg
<b>Dimension</b>	12 × 12 × 24 cm

# SAFETY INSTRUCTION

---

Please read carefully and make sure following all instructions provided in this user manual before using the product. Failure to comply with the instructions given in this user manual may result in serious injury and/or damage to the product.

- Before using the product for the first time, REMOVE and DISPOSE OF all packaging material and promotional labels carefully.
- Before discarding the packaging, double-check that you have received all indicated parts when unpacking the product.
- **MAKE SURE** power supply matches with voltage indicated on this product before use.
- **DO NOT** touch any live part of the appliance when it is powered on.
- **DO NOT** attempt to activate the motor without using the container and its cover.
- **DO NOT** leave foreign objects such as spoons, forks, and knives inside the container as this will damage the blades and other components when operating the appliance. Doing so may also cause injury.
- Handle this appliance with care, the blades are sharp.
- **DO NOT** place any part of product on or near gas, electric burner and in a heated oven.
- **DO NOT** immerse appliance, cord, or plug in water or other liquid.
- **DO NOT** let cord hang over edge of table or counter or touch the hot surface.
- **DO NOT** place the appliance in a cabinet when in use.
- **Switch off** the appliance and disconnect from supply before changing accessories or approaching parts that move in use.
- **DO NOT** operate the product with a damaged cord or plug, if its main cord is damaged, it must be replaced by the manufacturer, the nearest service agent, or a qualified person.
- **DO NOT** plug the appliance into the power supply until it is fully assembled and always unplug before disassembling the appliance or handle the blade.
- The max capacity is no more than the max mark, so **DO NOT** overfill over its capacity.
- **Short time operating ONLY**; use the appliance for **NO** longer than 1 minute, then take at least a 2-minute break.
- **DO NOT** process more than three batches without interruption. Let the appliance cool down to room temperature before you continue to process.
- Using an accessory **NOT** recommended by the manufacturer for use with this appliance may result in fire, electric shock, or injury to persons.
- **DO NOT** immerse appliance, cord, or plug in water or any other liquid.
- **DO NOT** place the base in dishwasher.
- **ALWAYS** unplug from outlet when not in use and before cleaning.
- **TO** disconnect the machine from power outlet, gently grasp the plug and remove, **DO NOT** pull the cord.
- **DO NOT** use the product for other unintended purpose and place it in a dry storage.
- **DO NOT** leave the appliance unattended while it is operating.
- Close supervision is necessary when this appliance is used near children
- The appliance should **NOT** be operated by children **NOR** shall play with the appliance.
- **DO NOT** let children or people with reduced physical or mental capabilities to use or clean the appliance.
- **MAKE SURE** to stand the appliance on a table or flat surface.
- **DO NOT** use cleansers, steel wool pads, or other abrasive material for cleaning the unit. When cleaning, only use a soft cloth and mild detergent.
- For reducing the risk of fire, **DO NOT** store anything directly on top of the appliance when it is in operation mode.
- **DO NOT** operate the appliance without full assembling of all parts.
- When assembling, using, or storing the product, **DO NOT** put anything on top of it.
- **MAKE SURE** to keep your appliance clean at all times. Follow the cleaning instructions in this user manual.
- **DO NOT** attempt to disassemble this appliance for any reason. If the appliance is broken or no longer functions properly, immediately discontinue use and contact customer support.
- **DO NOT** use outdoors.
- This appliance is intended to be used in household and similar applications such as:
  - staff kitchen areas in shops, offices and other working environments
  - farm houses
  - by clients in hotels, motels and other residential type environments
  - bed and breakfast type environments
- Misuse may cause injury.

**KEEP THESE IMPORTANT SAFETY INSTRUCTIONS IN  
A SAFE PLACE FOR FUTURE REFERENCE**

# PARTS NAME

---

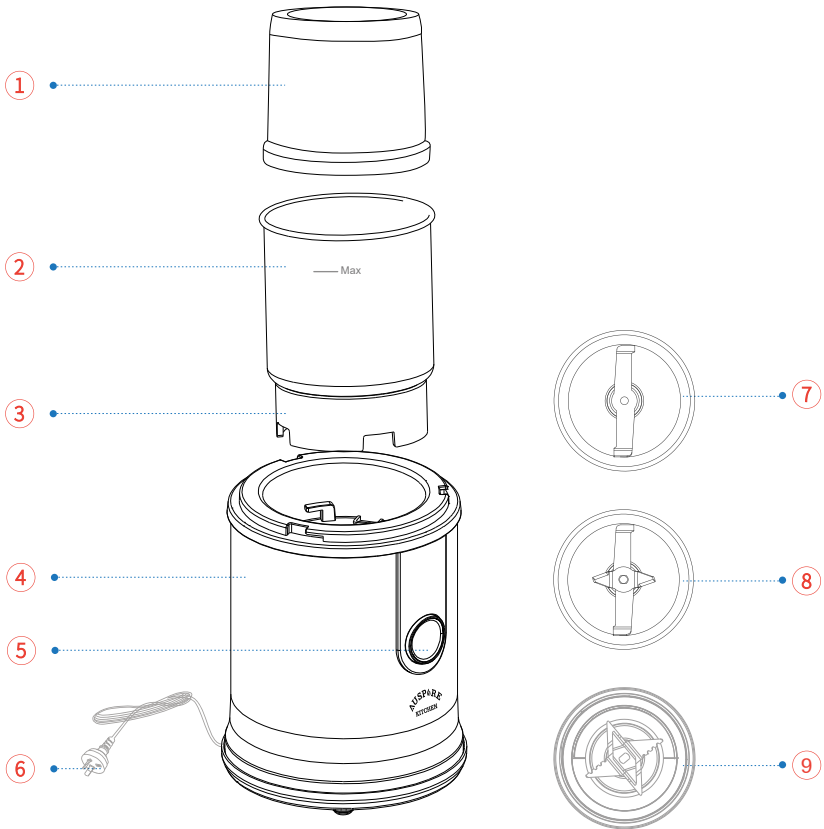

① Transparent Grinding Lid

② Removable Grinding Container

③ Grinding Container Base

④ Power Base

⑤ Power Control Switch (Push Button)

⑥ Power Plug

⑦ Stainless Steel Grinding  
Container 2-Blade

⑧ Stainless Steel Chopping  
Container 4-Blade

⑨ Plastic Portable Blending  
Container 6-Blade

## GETTING TO KNOW YOUR APPLIANCE

---

AusGrind-E09 is an advanced and robust electric coffee and spice grinder designed by Auspure kitchen. It features One-press/Push-button operation, easy cleaning and compact structure which makes it perfect kitchen appliance to provide you a rich aroma and taste. Choose between accessories, grinding cup for coffee bean and spice, chopping cup for wet ingredients, and portable Jar plus its blade for making your favourite blended fruits or vegetable juice.

**Note:** in main packaging, only grinder container is included, other accessories can be purchased separately to enable you for multipurpose operation.

# BEFORE THE FIRST-TIME USE

---

## Preliminary Check

1. After removing the packaging, make sure the product is complete and undamaged and that all accessories are present. Do not use the appliance if it is visibly damaged and contact customer support for technical assistance, troubleshooting or replacement if required.
2. Connecting the appliance; check that the mains power supply voltage corresponds to the value indicated on the rating label.  
If the power socket does not match the plug on the appliance, have the socket replaced with a suitable type, or change the plug by a qualified person.

## Accessories and Functionalities

### **Stainless Steel Grinding Container 2-Blade:**

Contains two blades and included in the package. It is used for grinding fresh coffee beans, dried herbs & spices. Too oily ingredients such as peanuts should not be used with this grinder to avoid mess and an inconvenience cleaning.

### **Stainless Steel Chopping Container 4-Blade:**

Contains four blades and is not included in the package. The main function is chopping wet foods such as onions, vegetables, fruits, earth-pea, garlic, herbs, and dry bread. It is better to not fill over 2/3 container capacity while using for chopping vegetables and fruits.

### **Plastic Portable Blending Container 6-Blade:**

The glass jar is perfectly suited for preparing juice, and baby food as well as for mixing and milkshakes. This accessory is a portable bottle/jar with a detachable 6-blade blending container and is not included in the package. It is also used for both blending vegetables or fruits and as an easy-carry and portable juice bottle.

# GETTING STARTED

---

The appliance is perfectly suited for coffee beans, nuts, herbs, beans as well as other ingredients to be considered with its suitable container.

For starting to operate your Auspure coffee and spice grinder, follow the steps below.

1. Place the appliance on a flat surface and the detachable container directly on it.

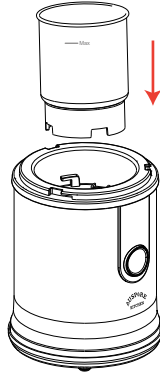

2. Pour the coffee beans/ingredients into the grinding container and fill to desired level not increasing from MAX level. As per general indications, consider one tablespoon of beans per cup.

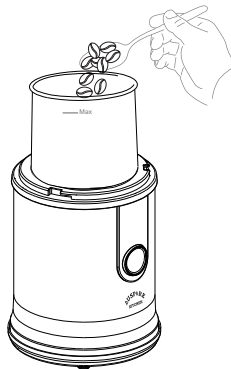



3. Tighten the lid by turning it fully home in an anti-clockwise direction. For safety reason it prevents switch-on if the lid is not well inserted.

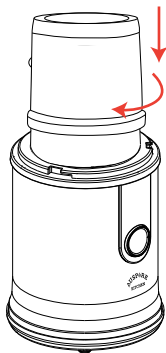

4. Do not attempt operation without the cover being in place.
5. Plug the appliance into the wall socket ensuring to use correct power supply.

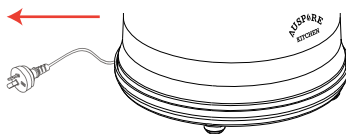

6. Press switch button to active the coffee grinder and hold it down until the desired level of grinding is obtained.

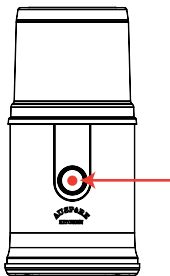

8. Unplug the unit gently and have a container ready to hold your coffee ground.

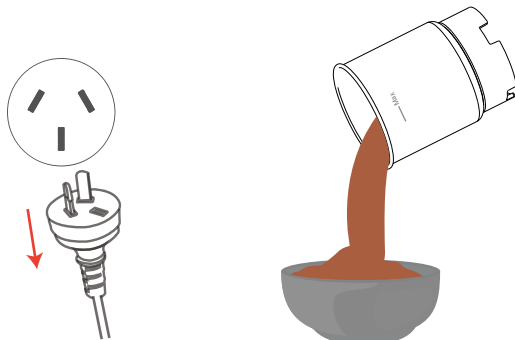

### General Tips and Recommendation for Use

- a. Coffee grounds left in your grinder can become stale and affect the flavour of freshly. Be sure to clean grinding bowl, blades and cover after each use.
- b. Use a small soft-bristled brush to remove grounds at the bottom of the grinding container after completing the job.
- c. The Coffee grinder container (included in the package) can only handle dry, brittle foods. Do not grind oil seeds (e.g. peanuts) or hard products (e.g. rice).
- d. As per general indications, consider one tablespoon of beans per cup. Naturally, optimal amounts, defined on the basis of personal taste, will be identified with time.
- e. Always keep the lid of bean container closed hermetically in order to preserve the flavour and the aroma of the coffee beans.
- f. Only grind the amount of coffee necessary at the time and never overfill the bean container.

## CLEANING AND CARE

---

Care should be taken for last longing and perfect operation of your Auspure Coffee and Spice Grinder. It is highly recommended to clean grinding bowl, blades, and cover after each use since the ingredients or coffee grounds left in your grinder can become stale and affect the flavour of your next time output. For safe cleaning follow the instructions below.

1. Make sure the appliance is unplugged from electrical outlet before cleaning.
2. The blades are sharp, always use caution when cleaning.
3. After each use, rinse out any remnants of the mixture with clean water. If necessary, use a sponge or cleaning brush to scrub off any tough food stains.
4. For deep cleaning and to remove residue or aromas left behind by nuts, grind one tablespoon of baking soda in the bowl then wipe thoroughly.
5. To avoid the risk of electric shock, do not clean the base or the power cord with water and do not immerse them.
6. Wash containers and transparent cover with warm soapy water and allow them to dry completely.
7. Wipe and dry the appliance with a soft cloth.
8. The containers and transparent cover are dishwasher-safe, it is recommended to place them on the top rack for washing.
9. Store excess cord by pushing a section at a time into the cord storage area in the base of the unit.
10. Store the cleaned parts in safe place away from children

## STORAGE

---



If not using your Coffee and Spice Grinder for an extended period of time, the following points must be considered for safe storage.

- Turn OFF the machine and then unplug from the power outlet.
- Follow the instructions on “CLEANING AND CARE” section to clean the unit and ready for storage.
- Store in a dry and safe place in upright position.
- Do not store anything on the top of the coffee grinder.

## DISPOSAL

---



- To prevent possible harm to the environment or human health from uncontrol waste disposal, separate the unneeded Coffee and Spice Grinder and its related accessories from other types of wastes.
- Ask your local council where to dispose of your coffee grinder and its related accessories.
- You should not throw your Coffee and Spice Grinder and its related accessories away with the daily normal household waste.

# TROUBLESHOOTING

NO	PROBLEM !	POSSIBLE CAUSE	SOLUTION ✓
1	The appliance cannot be turned on	<ol style="list-style-type: none"> <li>1. The lid might not be well positioned.</li> <li>2. There might be issues with plug or power source.</li> </ol>	<ol style="list-style-type: none"> <li>1. Check and replace the lid to be fairly positioned.</li> <li>2. Ensure that the appliance is plugged properly into a functioning outlet.</li> <li>3. If the issue is not resolved, contact customer support <a href="mailto:support.au@auspure.com">support.au@auspure.com</a>.</li> </ol>
2	The appliance stops circulating while grinding	<ol style="list-style-type: none"> <li>1. The blade might be stuck.</li> <li>2. Overheat protection is activated.</li> </ol>	<ol style="list-style-type: none"> <li>1. Remove the plug from power source. To loosen the coffee beans stuck on the blade, use a spatula. During the next grinding, lower the amount of ground ingredients.</li> <li>2. Remove the plug from power source and let the appliance to cool down for 30 min before operating again.</li> <li>3. If the issue is not resolved, contact customer support <a href="mailto:support.au@auspure.com">support.au@auspure.com</a>.</li> </ol>
3	There is an unusual smelling while grinding	<ol style="list-style-type: none"> <li>1. Overloading issue.</li> <li>2. Overtime usage.</li> </ol>	<ol style="list-style-type: none"> <li>1. Lower the amount of ingredients under the indicated MAX line in the container.</li> <li>2. Stop and let the appliance cool down for 30 min before operating the machine again.</li> <li>3. If the issue is not resolved, contact customer support <a href="mailto:support.au@auspure.com">support.au@auspure.com</a>.</li> </ol>
4	The grinding output is being too finely	The push button is pressed for longer time.	For a coarser grind size, hold the push button for shorter period.
5	The grinding outputs are inconsistent	Push button is not held consistently while grinding.	Do not let it go while holding the push button for a consistent output size.

# WARRANTY INFORMATION

---

Auspure Coffee and Spice Grinder is designed and manufactured to the highest quality standards. Your appliance is covered for parts and labour for 2 years, which includes 1 year standard warranty and 1-additional year upon registration (free of charge within 14 days) from the date of purchasing.

## WARRANTY INFORMATION TABLE

Product Name	Easy Electric Coffee & Spice Grinder
Model	AusGrind-E09
Default Warranty	1-Year Standard Warranty
Additional Warranty	1-Year extendable warranty by simply registering to <a href="http://www.auspure.com/au">www.auspure.com/au</a> within 14-day of original purchase
Purchasing Date	...../...../.....
Order Number	
Purchasing Store	

This warranty and disclaimer applies to all products purchased via the website [www.auspure.com/au](http://www.auspure.com/au) (hereinafter "Products") or a third party seller authorised by Auspure.

**Note:** When the product is purchased from an authorised third party seller, for warranty claim, return and replacement of a defective product, the inquiry should be lodged on the related third party seller.

## (1) Warranty Against Defects

### 1.1 For Brand-new Products:

We provide a 12-month standard warranty against defects with the Products, from the date of purchase.

We provide an optional additional free 12-month extended warranty against defects with the Products (resulting in a 24-month warranty against defects with the Products, from the date of purchase).

In order to claim the additional 12-month extended warranty, you must register your Product (free of charge) online at [www.auspure.com/au](http://www.auspure.com/au), within 14 days of the date of purchase. While registration, make sure that the related data entry including the date of purchasing are accurate.

In the event of a defect with the Product, you may be entitled to have the Product replaced. In order to be entitled to a replacement Product, you must:

- immediately stop using the Product; and
- notify us of the defect during the warranty period.

In order to claim a replacement Product, you must contact us using the details at the CUSTOMER SUPPORT section, to notify us of the defect, providing your proof of purchase and warranty registration confirmation as well as your contact details.

You may either:

- return the product for our further investigation; or
- send us a video of the defective Product, which demonstrates to our reasonable satisfaction that the Product is defective and undertake to safely dispose the defective Product. For safety reasons you must not continue to use the defective Product.

Upon receipt of the defective Product, or a video of the defective Product, we will inspect it. If the defect is the result of a manufacturer fault, we will determine if the fault requires a replacement or repair and either send you a replacement Product or effect a repair.

This warranty against defects is in addition to any other rights and remedies to which you may be entitled under Australian law.

To Clarify:

**What is covered by the warranty:**

- The repair or replacement of your Auspure product (at Auspure's discretion) if the product is found to be defective due to faulty manufacture. Auspure reserves the right to determine if the fault requires a replacement or repair.
- Packaging and instructions of a faulty product may also be replaced if damaged.
- This warranty is valid for using your personal use of your device within Australia only.

**What is not covered by the warranty:**

- Using the products for commercial purposes, or anything other than normal domestic personal use.
- Use of the product outside Australia.
- Accidental damage or faults caused by negligence, misuse, vandalism or neglect.
- Damage or faults caused by not following the instructions in the user manual.
- Unsupervised use by children under the age of 18.
- Repairs or alterations carried out by parties other than Auspure or an authorised agent.
- Any other conditions not listed above, are not covered by Auspure warranty.

## **1.2 For Renew Products:**

A renew Product, which is purchased from a seller that is authorised by Auspure, is only covered under six months warranty and is not eligible for the free warranty extension.

## **1.3 For Replacements:**

Replacement of a brand-new Product is only covered by the one-year standard warranty from the date of replacement arrangement and is not eligible for the one-additional year free warranty extension.

Replacement of a renew Product that is purchased from a seller and is authorised by Auspure is only covered by six months warranty from the date of replacement arrangement and is not eligible for the free warranty extension.

## **(2) Australian Consumer Law**

Our goods come with guarantees that cannot be excluded under the Australian Consumer Law. You are entitled to a replacement or refund for a major failure and compensation for any other reasonably foreseeable loss or damage. You are also entitled to have the goods repaired or replaced if the goods fail to be of acceptable quality and the failure does not amount to a major failure.

## **(3) Disclaimer**

You are solely responsible for evaluating the Product and determining whether it is fit for your purpose.

You acknowledge and agree that Product is not safe for use by children.

You acknowledge and agree that working with the Product is dangerous and carries the risk of electric shock, burns, lacerations, other injuries and death.

You acknowledge that you use the Product at your own risk and that you are responsible at all times for evaluating whether or not it is safe to use the Product.

## **(4) Limitation of Liability**

In addition to the requirements set out in clause 1 of this warranty and disclaimer document, the warranty provided under that clause will not apply:

- if a defect with the Product results in any way from some act or omission by you in relation to the appropriate care, maintenance and/or use of the Product; or
- if a defect with the Product results from ordinary wear and tear; or
- if you fail to follow our or the manufacturer's instructions for care, maintenance and/or use of the Product; or
- if you are unable to provide proof of purchase.



Except as otherwise provided by law, we accept no liability for any loss, damage or injury which may arise in any way from the use of the Product by you or by any other person.

Except as otherwise provided in this warranty and disclaimer, to the maximum extent permitted by law, we exclude all conditions and warranties implied by custom, law or statute, and we expressly disclaim all warranties of any kind including but not limited to implied warranties that the Product is fit for a particular purpose.

You hereby agree that we are not liable for any direct, indirect, consequential or incidental loss or damage which may result from your use of the Product.

Except as otherwise provided by law or as otherwise set out in this warranty and disclaimer, our liability to you shall be limited to the cost of replacement of the Product, together with your reasonable costs of postage and/or delivery in connection with your returning of the Product.

## **(5) Indemnity**

You agree to defend, indemnify and hold us and our officers, directors, employees, contractors, members, agents and licensees harmless from and against any and all claims, charges, actions, liabilities, investigations, demands and similar including but not limited to any costs, losses, damages whether direct, indirect, consequential or special and all legal fees resulting from your use of the Product, including but not limited to any third party claims.

## **DEFECTIVE PRODUCTS AND RETURNS**

---

Proved defective product meeting the specified warranty period, should be contacted Customer Support via [support.au@auspure.com](mailto:support.au@auspure.com) addressing your order number. Make sure to NOT dispose of your product before contacting us. Once our Customer Support Team has reached to your request approval, please return the unit with its order number.

## **AUSPURE CUSTOMER SUPPORT**

---

Feel free to contact our helpful customer support team with any questions regarding your product!

Your satisfaction is our priority.

Ausbrilliant. PO Box 2, Ermington NSW 1700, Australia

[www.auspure.com/au](http://www.auspure.com/au)

[support.au@auspure.com](mailto:support.au@auspure.com)

Please provide your order number when you contact our customer support services.





# AUSPURE KITCHEN



Questions or Inquiries?  
[support.au@auspure.com](mailto:support.au@auspure.com)  
V1.0622