

GENERAL NOTES:

1. GUARDRAIL SHALL BE DESIGNED IN ACCORDANCE WITH THE IBC 1607.8.2015 BUILDING CODE
 - 1.1. HANDRAILS AND GUARDRAILS SHALL BE DESIGNED TO RESIST A LINEAR LOAD OF 50 POUNDS PER LINEAR FOOT. HANDRAILS AND GUARDRAILS SHALL BE DESIGNED TO RESIST A CONCENTRATED LOAD OF 200 POUNDS.
 - 1.2. INTERMEDIATE RAILS, BALUSTERS AND PANEL FILLERS SHALL BE DESIGNED TO RESIST A CONCENTRATED LOAD OF 50 POUNDS.
2. CONTRACTOR SHALL BEAR RESPONSIBILITY FOR PROVIDING ALL WORK AND MATERIALS IN ACCORDANCE WITH APPLICABLE CODES AND STANDARD (FEDERAL, STATE, AND COUNTY), HAVING JURISDICTION OVER SUCH WORK. ALL APPLICABLE REQUIREMENTS IN THESE REGULATIONS SHALL BE FOLLOWED THE SAME AS IF NOTED ON THE DRAWINGS.
3. VERIFY THAT REQUIRED CLEARANCES ARE OBTAINED PRIOR TO COMMENCEMENT OF THE WORK.
4. D.H CHARLES ENGINEERING, INC. OR INLINE DESIGN GROUP, INC. WILL NOT SUPERVISE, DIRECT, CONTROL OR HAVE AUTHORITY OVER OR BE RESPONSIBLE FOR CONTRACTOR'S MEANS, METHODS, TECHNIQUES, SEQUENCES OR PROCEDURES OF CONSTRUCTION , OR SAFETY PRECAUTIONS AND PROGRAMS INCIDENT THERE TO, OR FOR ANY FAILURE OF CONTRACTOR TO COMPLY WITH LAWS AND REGULATIONS APPLICABLE TO THE FURNISHING OR PERFORMANCE OF WORK
5. STRUCTURAL STEEL SHOP DRAWINGS SHALL BE SUBMITTED TO THE ENGINEER-OF-RECORD FOR REVIEW. SHOP DRAWING REVIEW AND APPROVAL BY THE ENGINEER ARE NOT CHANGE ORDERS. ENGINEER'S REVIEW AND APPROVAL IS ONLY TO CONFIRM CONTRACTOR UNDERSTANDS THE DESIGN CONCEPT BY INDICATING WHICH MATERIAL IS INTENDED TO BE FURNISHED AND INSTALLED AND BY DETAILING THE INTENDED FABRICATION AND INSTALLATION METHODS.
6. ADEQUACY OF EXISTING STRUCTURE TO PASS LOADS IMPOSED BY EQUIPMENT SHOWN ON THESE PLANS HAS NOT BEEN VERIFIED BY, NOR IS THE RESPONSIBILITY OF , D.H. CHARLES ENGINEERING, INC OR INLINE DESIGN GROUP, INC . AND MUST BE VERIFIED BY THE ENGINEER OF RECORD (EOR) FOR USE.
7. ATTACHMENT OF THE GUARDRAIL SYSTEM TO THE EXISTING STRUCTURE SHALL BE DESIGNED BY A PROFESSIONAL ENGINEER.
8. ANY CHANGES TO THE EQUIPMENT LOADING OR LAYOUT SHOWN ON THESE PLANS MUST BE VERIFIED PRIOR TO SYSTEM USE.
9. IT IS THE SOLE RESPONSIBILITY OF THE PROJECT ARCHITECT TO CERTIFY THAT THE RAIL SYSTEM IS APPROPRIATE FOR THIS BUILDING.
10. CONTRACTOR IS FULLY RESPONSIBLE FOR PATCHING AND WEATHERPROOFING ALL PENETRATIONS IN ROOF AND/OR WALL COVERINGS DUE TO INSTALLATION OF NEW ASSEMBLIES.
11. MATERIALS:
 - 11.1 STEEL:
 - 11.1.1 ALL STAINLESS STEEL PLATES AND SHAPES TO BE ASTM A240 SS316 WITH YIELD STRESS EQUAL TO OR GREATER THAN 40 KSI U.O.N
 - 11.1.2 ALL STAINLESS STEEL TUBE MEMBERS TO BE ASTM A240 SS316 WITH YIELD STRESS EQUAL TO OR GREATER THAN 40 KSI U.O.N
 - 11.1.3 ALL STAINLESS STEEL SCREWS SHALL BE ASTM B18.3.5, DIN 7791 SS316: WITH YIELD STRESS EQUAL TO 100 KSI OR GREATER U.O.N
 - 11.1.4 ALL CABLE SHALL BE ASTM A492-95 AISI316 1X19 WITH MINIMUM TENSILE STRENGTH OF 22 KSI U.O.N
 - 11.1.5 ALL STAINLESS STEEL PLATES AND SHAPES FINISHES SHALL BE ASTM A480 11.1.9 NO 4 LINEARLY TEXTURED FINISH WITH A RA UP TO 25 MICRO-INCHES.
 - 11.2 WELDING:
 - 12.1.1 WELDING SHALL BE PERFORMED BY A CERTIFIED WELDER IN STRICT ACCORDANCE WITH THE LATEST EDITION OF THE AMERICAN WELDING SOCIETY (A.W.S) D1.1
 - 12.1.2 USE 316I FILLER METAL.
 - 12.1.3 WELDING SHALL BE INSPECTED AND APPROVED BY AN INDEPENDENT AGENT.

The above drawings and specifications and ideas, designs and arrangements represented thereby are and shall remain the property of the Inline Design Group and no part thereof shall be copied, disclosed to others, resold or used in connection with any work or project other than the specified project for which they have been prepared and developed without the written consent of Inline Design Group. Visual contact with these plans or specifications shall constitute conclusive evidence of acceptance of these restrictions. Written dimensions on these drawings shall have precedence over scaled dimensions; contractor or homeowner shall verify and be responsible for all dimensions and conditions on the job, and Inline Design Group must be notified on any variations from the dimensions and conditions shown by these drawings. Shop details must be submitted to Inline Design Group for approval before proceeding with fabrication.

SCALE:



DRAWING:

GENERAL NOTE

6335 1st Ave. South Unit Main
Seattle, WA 98108
Tel: 425 405 5505
Fax: (866) 864-0608

<https://inlinedesign.com>
sales@inlinedesign.us
support@inlinedesign.us

SKU:

DIMENSIONS ARE IN INCHES

REVISION:

REV 1.01

MATERIAL:

ASTM A240

TOLERANCE:

+/- 1/16"

SIGNED

VT 12/09/18

TV 01/13/19

SHEET: 1 OF 1

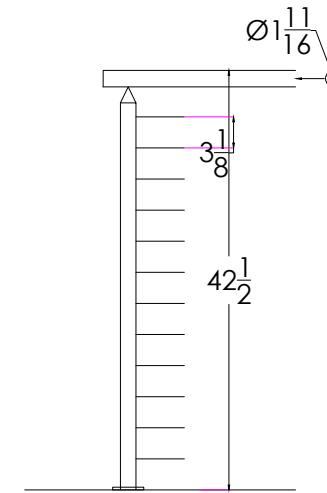
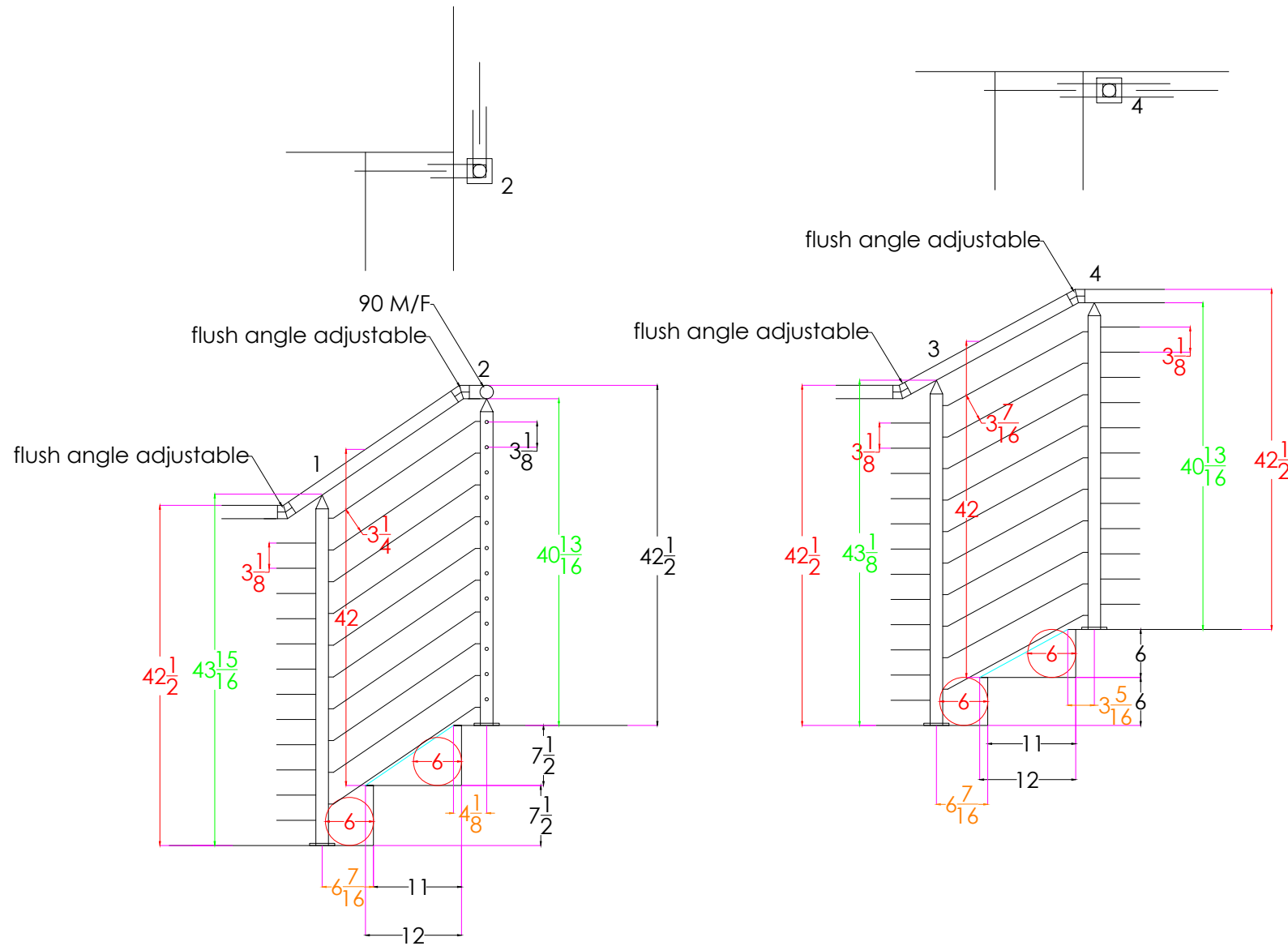

Stock Post

End Post - Qty: 2
Middle Post - Qty: 16
Corner Post - Qty: 3

42" Stock Top Mount Specs

- Custom posts
1. Lower 180
 2. Upper 90 Left
 3. Lower 180
 4. Upper 180

The above drawings and specifications and ideas, designs and arrangements represented thereby are and shall remain the property of the Inline Design Group and no part thereof shall be copied, disclosed to others, resold or used in connection with any work or project other than the specified project for which they have been prepared and developed without the written consent of Inline Design Group. Visual contact with these plans or specifications shall constitute conclusive evidence of acceptance of these restrictions. Written dimensions on these drawings shall have precedence over scaled dimensions; contractor or homeowner shall verify and be responsible for all dimensions and conditions on the job, and Inline Design Group must be notified on any variations from the dimensions and conditions shown by these drawings. Shop details must be submitted to Inline Design Group for approval before proceeding with fabrication.

SCALE:

n/a



CUSTOMER NAME:

Debra Ramirez

ORDER NUMBER:

R11204949

REVISION:

REV 1.01

MATERIAL:

ASTM A240

TOLERANCE:

+/- 1/16"

SIGNED

VT

VT

DATE

06/27/2023

06/29/2023

SHEET:

1 OF 1

6335 1st Ave. South Unit Main
Seattle, WA 98108
Tel: 425 405 5505
Fax: (866) 864-0608

<https://inlinedesign.com>
sales@inlinedesign.us
support@inlinedesign.us

DIMENSIONS ARE IN INCHES