



WARNING

Serious injury or death can occur if caution is not used. To reduce the risk of serious injury, read the following instructions and warnings. Keep these instructions for future reference. Before beginning any exercise program, consult your physician. This is especially important for those over the age of 35 or those with pre-existing health conditions.

1. This product meets industry standards for stability when used for its intended purpose in accordance with the instructions provided.
2. Using this rack for support during stretching or attaching resistance bands, straps, ropes, or any other means to this rack may result in serious injury.
3. It is the responsibility of the owner to ensure that all users of this rack are adequately informed of all precautions.
4. Inspect and properly tighten all parts regularly. Replace any worn parts immediately.
5. Keep children and pets away from this product at all times.
6. Keep this product indoors, away from moisture and any other water.
7. Place the rack on a clean, flat, and level surface.
8. Manufacturer is not responsible for any injury or death caused by improper use or improper assembly.
9. This product is designed and intended for **consumer/home use only** in an indoor environment. Do not use it in a commercial, rental, or institutional setting.

MAINTENANCE

The safety and integrity designed into this rack can only be maintained when the equipment is regularly examined for damage and repaired. It is the sole responsibility of the user/owner to ensure that regular maintenance is performed. Worn or damaged components should be replaced immediately and stop using the equipment until the repair is made.

1. Wipe rack regularly to prevent accumulation of dust.
2. Use a dry cloth to clean the metal frames.
3. Avoid acid chlorine based cleaners and those containing abrasives as these could scratch or damage the equipment.
4. Check regularly to ensure all parts are tight and in working condition. If a part is damaged, do not use until the parts are replaced or repaired.

**EPIC
FITNESS**

OWNERS MANUAL

5-Tier A-Frame Dumbbell Rack

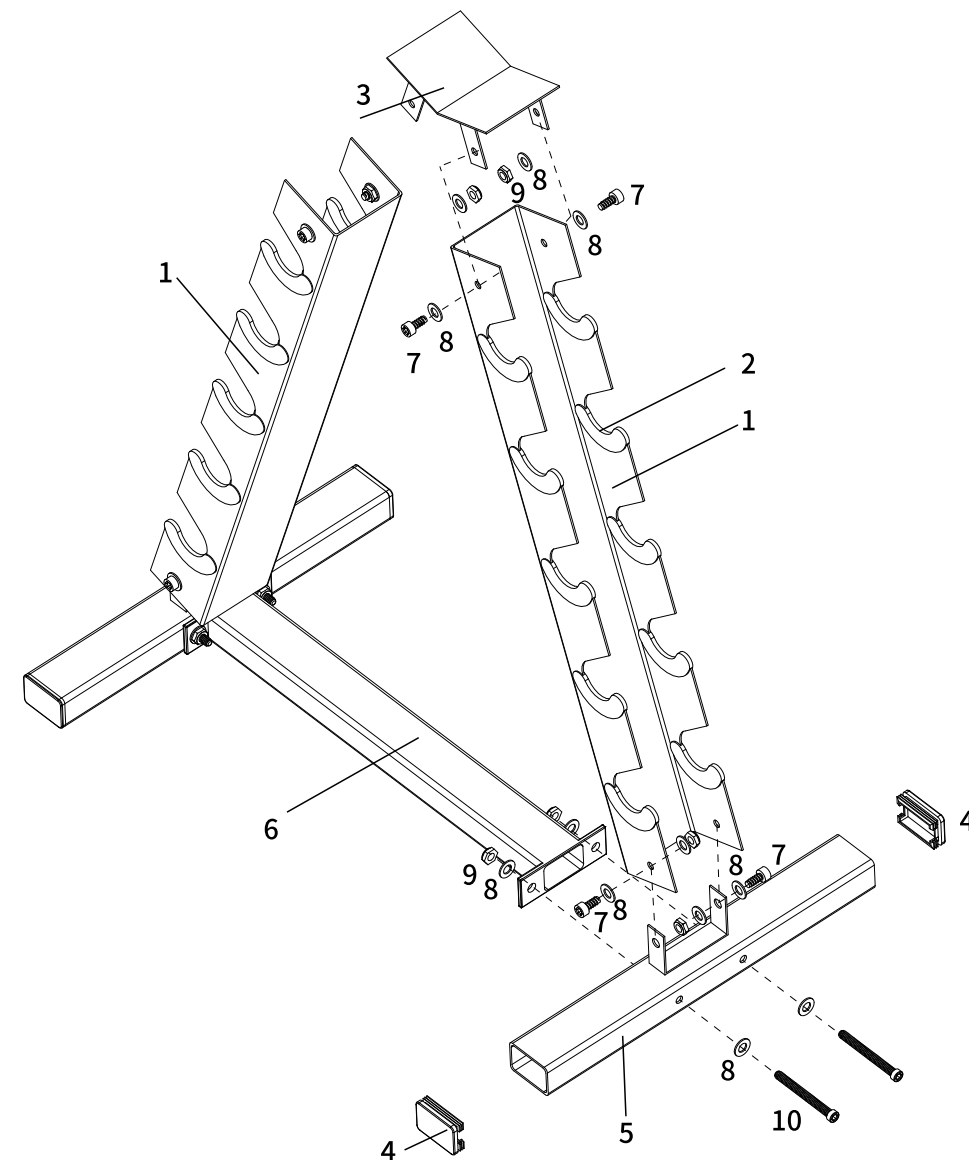

ASSEMBLY

STEP 1

Connect the two U-Frame Supports (#5) to the Center Cross Base (#6) using two bolts (#10), four washers (#8) and two nuts (#9) on each side. Insert the end caps (#4) on the U-Frame Supports (#5) if not already attached.

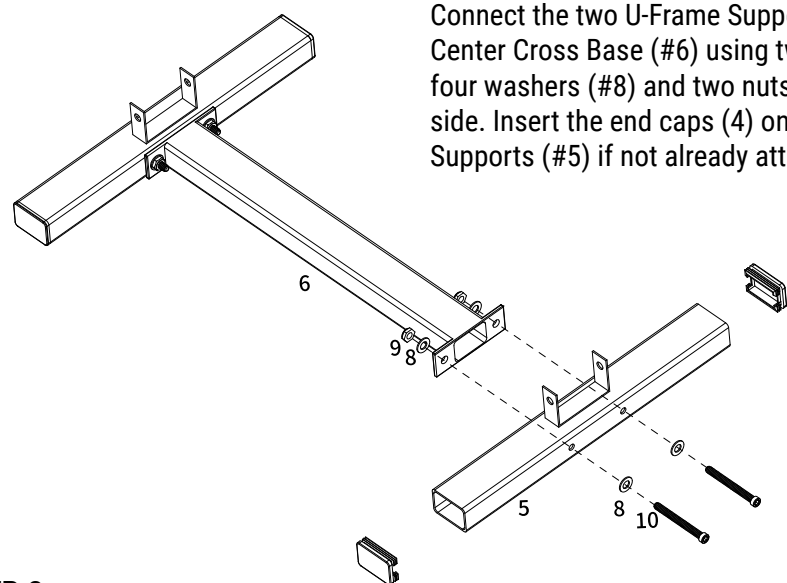

STEP 2

Insert the two Main Frames (#1) into the U-Frame Supports (#5) using two bolts (#7), four washers (#8), and two nuts (#9) on each side.

STEP 3

Place the Top Cap (#3) onto the Main Frames (#1), secure them with four bolts (#7), eight washers (#8), and four nuts (#9). Place the 20 Dumbbell Cradles (#2) onto the dumbbell slots to cushion the dumbbell handles. Secure each cradle with the included 20 plugs.

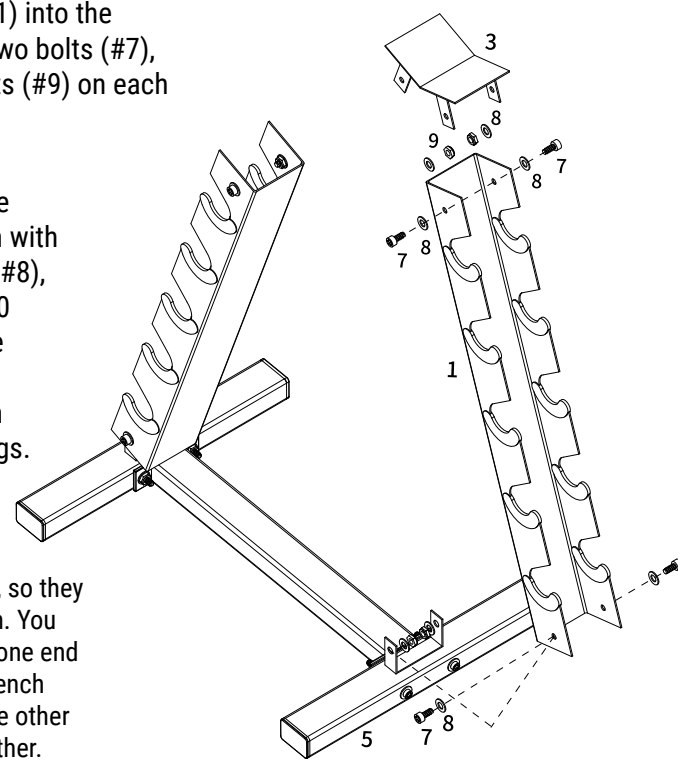

Fully Tighten Your Hardware:

These particular nuts are lock nuts, so they are near impossible to hand-tighten. You need the included allen wrench on one end tightening the bolt, along with a wrench (not included) around the nut on the other end to fully tighten everything together.

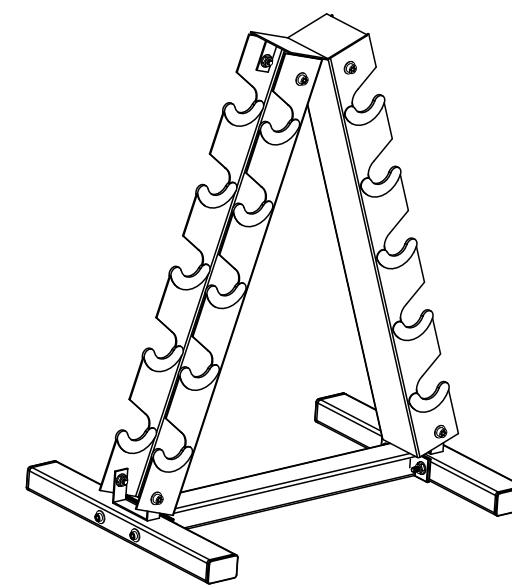

PART LIST

	1) Main Frame (X2)		7) Bolts M10x19mm (X8)
	2) Dumbbell Cradles (X20)		8) Washers M10 (X24)
	3) Top Cap (X1)		9) Nuts M10 (X12)
	4) End Caps (X4)		10) Bolts M10x86mm (X4)
	5) U-Frame Supports (X2)		11) Allen Wrench (X1)
	6) Center Cross Base (X1)		12) Cradle Plugs (X20)



Not included: Wrench for Self-Locking Nuts