



Service Manual

Rol-Lift

Series: T and E

This manual is intended for basic service and maintenance of the Rol-Lift pallet jack.

The pallet jacks you are servicing are tools that make moving products easier. Operating pallet jacks with rusty, broken or worn parts makes usage and maintenance more difficult.

Pallet jack parts are inexpensive and easy to replace. To ensure maximum life from the jack, always replace the parts that are broken or worn. Remember that all parts on a pallet jack depend on the adjoining parts to work properly and to perform to their full potential. When used in conjunction with our catalog, this service manual will explain how and when to replace a pallet jack part.

Remember, when in doubt... replace it.

888-999-7715

Contents

2	Suggested Assemblies
2	Commonly Used Tools
2	Helpful Reminders
3	Axles
3	Bushings
4	Load Rollers and Load Roller Brackets
6	Steer Wheels and Axle
7	Traverse
8	Push Rods
10	Lifting Link
12	Handle Removal and Installation
	Hydraulic Unit
13	Inspection
14	Service Hints
15	Removal
15	Installation

Copyright © 2016 Fast Lift Parts. All rights reserved.
Rol-Lift pallet jacks (all models) are products of L & L Fabrications.

Suggested Assemblies to Save Repair Time

- RL T5B0K-F-Super
Super Seal Kit for Foot Control
- RL T5B0K-H-Super
Super Seal Kit for Hand Control
- RL-32
Ultra-Poly Steer Wheel Assembly
- RL-31-A-D-Super
Super Ultra-Poly Load Roller Kit
- RL-31-D
Ultra-Poly Load Roller
- RL -31-3-Super
Super Poly Load Roller Kit



Commonly Used Tools

- Hammer
- Jack Stand
- 45° Snap ring pliers (large and small)
- 3/4" Wrench
- 9/16" Wrench
- 1/4" Allen wrench
- 1/4" Pin punch
- 3/16" Pin punch
- Soft hammer (nylon mallet)
- Anti-seize compound
- Lubricant (i.e. WD40 may be necessary to remove rusted parts)

PIN PUNCH

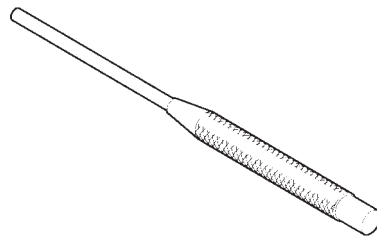

SNAP RING PLIERS

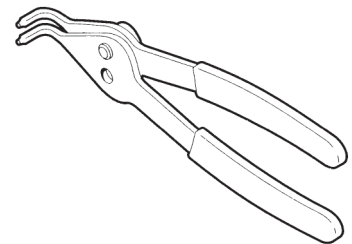

Helpful Reminders

- Never hammer directly on an axle; always use a pin punch.
- Always replace old roll pins and snap rings.
- Replace accessible bushings whenever the jack is torn down.

Axles

Inspection

If the axle is bent, out-of-round or shows signs of wear, replace it. Check for worn snap ring grooves and roll pin holes. If these are damaged or worn, replace the axle. The standard height jacks have a knurl on one end of the axle to prevent it from spinning. Insert the end of the axle **without** the knurl first for easier installation.

Bushings

Bushings are designed to wear out sooner than the mating parts. They are made of softer material and are expendable. It is recommended that anytime the jack is torn down to a point where the bushings are accessible, they be replaced. This will ensure longer life of the jack and will reduce the amount downtime. Bushings are very inexpensive and it is cost-effective to change them regularly.

Inspection

If the bushings are cracked, broken, egg-shaped or worn more than 1/16" from the original size, replace them.

Remember: If the jack is already disassembled, replace all accessible bushings.

Tip: Coating axles and bushings with anti-seize compound before installation makes future maintenance easier.

Load Rollers and Load Roller Brackets

Inspection

Load rollers - Load rollers should not have flat spots or large pieces of metal imbedded in them (i.e. tacks, nails or metal shavings). Any chips in the wheel that keep it from rolling smoothly indicate the need for replacement. If the wheel has cracks, loose tread or does not turn freely, replace both wheels. Always change the wheels in pairs to reduce uneven wear. New load rollers have an outside diameter of 3" or 3 1/4". If the diameter is worn more than 1/4" from normal size, replacement is necessary.

Load roller brackets - Inspect the bracket for cracks or broken welds. Ensure the axle holes are not out of round. Replace the bracket if it has worn thin due to prolonged rubbing on the floor. Also check the bushings closely (see Bushing Inspection).

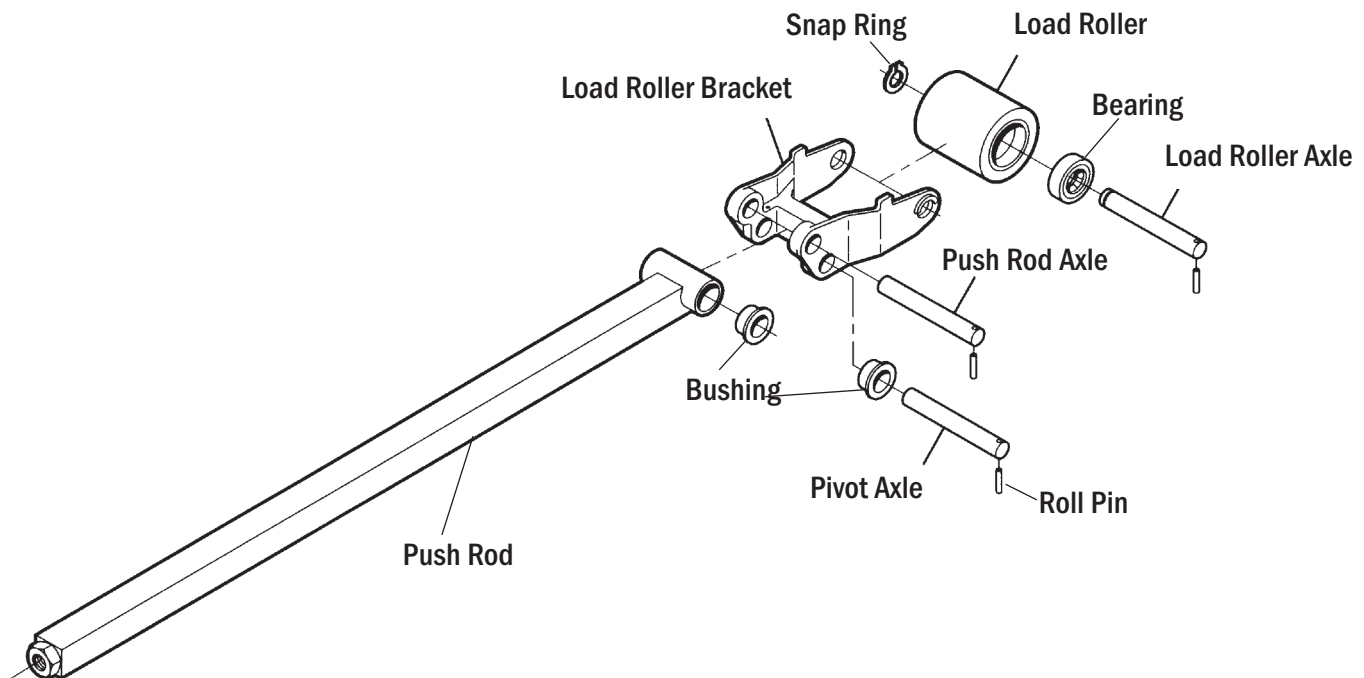

Load Rollers and Load Roller Brackets

Removal

Tip: We recommend servicing one load roller assembly at a time, using the other assembly as a reference.

Load rollers

Standard height - Turn the jack over onto its side. Remove one of the snap rings and punch the axle out of the wheel and bracket. (10 minutes)

Lowered height - Turn the jack over onto its side. Remove the roll pin and punch the axle out of the wheel and bracket.

(10 minutes)

Load roller brackets

Standard height - Turn the jack over onto its side and remove the load roller. Remove the snap ring on the pivot axle and punch it out of the frame and bracket. Remove the snap ring and drive the push rod axle out of the bracket.

(15 minutes)

Lowered height - Turn the jack over onto its side and remove the load roller. Remove the roll pin securing the pivot

axle in place and punch the axle out. Remove the roll pin fastening the push rod axle to the bracket and drive the axle out.

(15 minutes)

Installation

Load roller brackets

Standard height - With the jack on its side, insert the axle through the bracket and the push rod. Secure it in place with the snap rings. Attach the bracket to the frame by inserting the pivot axle through the frame and bracket. Secure in place with the snap rings. Install the load roller. Insert the end of the axle without the knurl first for easier installation.

(15 minutes)

Lowered height - With the jack on its side, insert the push rod axle into the bracket and push rod. Secure it in place with the roll pin. Fasten the bracket to the frame by inserting the pivot axle through the frame and bracket and securing

the axle in place with the roll pin. Install the load roller. (15 minutes)

Load rollers

Standard height - With the jack on its side, insert the axle through the bracket and wheel. Secure it in place with the snap ring. Insert the end of the axle without the knurl first for easier installation.

(10 minutes)

Lowered height - With the jack on its side, insert the axle through the bracket and wheel. Secure the axle in place by replacing the roll pin. (10 minutes)

Steer Wheels and Axle

Inspection

Steer wheels should not have flat spots or large pieces of metal imbedded in them (i.e. tacks, nails or metal shavings). Chips in the wheel, which keep it from rolling smoothly, indicate the need for replacement. Steer wheels should turn freely. They should not rub the bottom of the traverse. If they do, check for the correct installation of the snap ring under the traverse. Rol-Lifts older style steer wheel has an 8" diameter and their newer style has a 7 1/2" diameter. If the wheel is worn more than 1/4" from the normal diameter, replacement is necessary.

Removal

Steer wheels

Standard height - With the jack on its side, remove the roll pin and the wheel will be free to slide off. (10 minutes)

Lowered height - Turn the jack onto its side, remove the snap ring and the wheel will be free to slide off. (10 minutes)

Steer wheel axle

Standard height - Turn the jack onto its side and remove the steer wheels. Remove the snap ring on the pin that fastens the axle to the stem of the hydraulic unit. Punch the pin out of the stem and the steer wheel axle will be free to remove. (15 minutes)

Lowered height - Turn the jack onto its side and remove the steer wheels. Remove the snap ring on the pin that fastens the axle to the stem of the hydraulic unit. Punch the pin out of the stem and the steer wheel axle will be free to remove. (15 minutes)

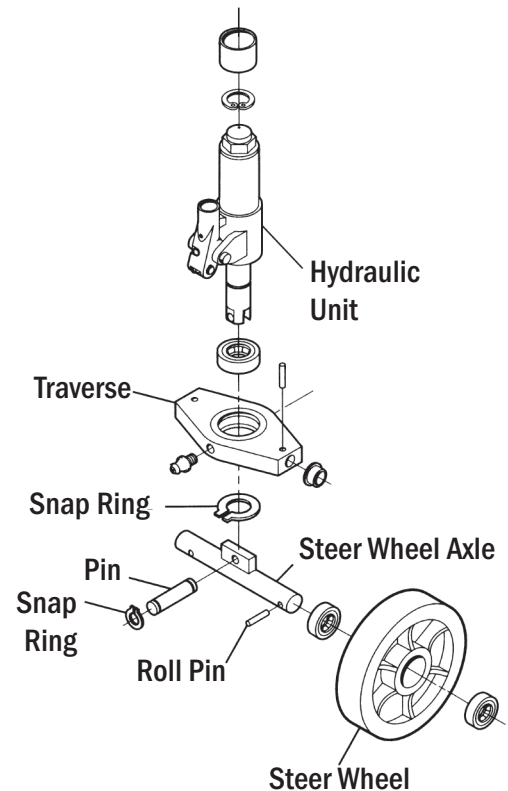

Installation

Steer wheel axle

Standard height - With the jack on its side, line up the pivot hole on the steer wheel axle with the hole in the stem of the hydraulic unit and insert the pin that attaches the axle to the hydraulic unit. Secure the pin in place with its snap rings. Slide the steer wheels onto the axle and secure them in place with the roll pins. (15 minutes)

Lowered height - With the jack on its side, line up the pivot hole on the steer wheel axle with the hole in the stem of the hydraulic unit and insert the pin that attaches the axle to the hydraulic unit. Secure the pin in place with its snap rings. Slide the steer wheels onto the axle and secure them in place with the snap rings. (15 minutes)

Steer wheels

Standard height - Slide the steer wheels onto the axle and secure them in place with the roll pins. (10 minutes)

Lowered height - Slide the steer wheels onto the axle and secure them in place with the snap rings. (10 minutes)

Traverse

Inspection

There are few things that can be wrong with the traverse. Wear can occur on the bearing shoulder or where the shoulder pins attach to the lifting link. If these areas are egg-shaped or out-of-round, replace the traverse.

Removal

Pump up the jack to gain access to the snap ring that secures the thrust bearing assembly, on top of the ram, to the A-Frame. Turn the jack onto its side and remove the steer wheels, steer wheel axle (see *Steer Wheels and Axle*) and the snap ring that holds the traverse in place on the stem of the hydraulic unit. Turn the jack back over and carefully lower the stem of the hydraulic unit onto the ground. Remove the snap ring securing the upper thrust bearing assembly in place, and lift the frame off of the ram. Pull the hydraulic unit out of the traverse with the traverse bearing. Punch out the roll pins that fasten the shoulder pins to the traverse. Remove the shoulder pins and the traverse. (25 minutes)

Installation

Position the traverse between the ears of the lifting link. Insert the shoulder bolts through the lifting link and into the traverse. Secure the shoulder pins with their roll pins. Position the traverse bearing onto the stem of the hydraulic unit and slide the hydraulic unit into the traverse. Raise the frame and insert the top of the ram, with the thrust bearing assembly still in place, into the top of the A-Frame. Pump the jack up to its maximum height and insert the snap ring that secures the thrust bearing assembly in place. Install the snap ring under the traverse onto the stem of the hydraulic unit. Assemble the steer wheel axle and the steer wheels (see *Steer Wheels and Axle*) to the hydraulic unit. (25 minutes)

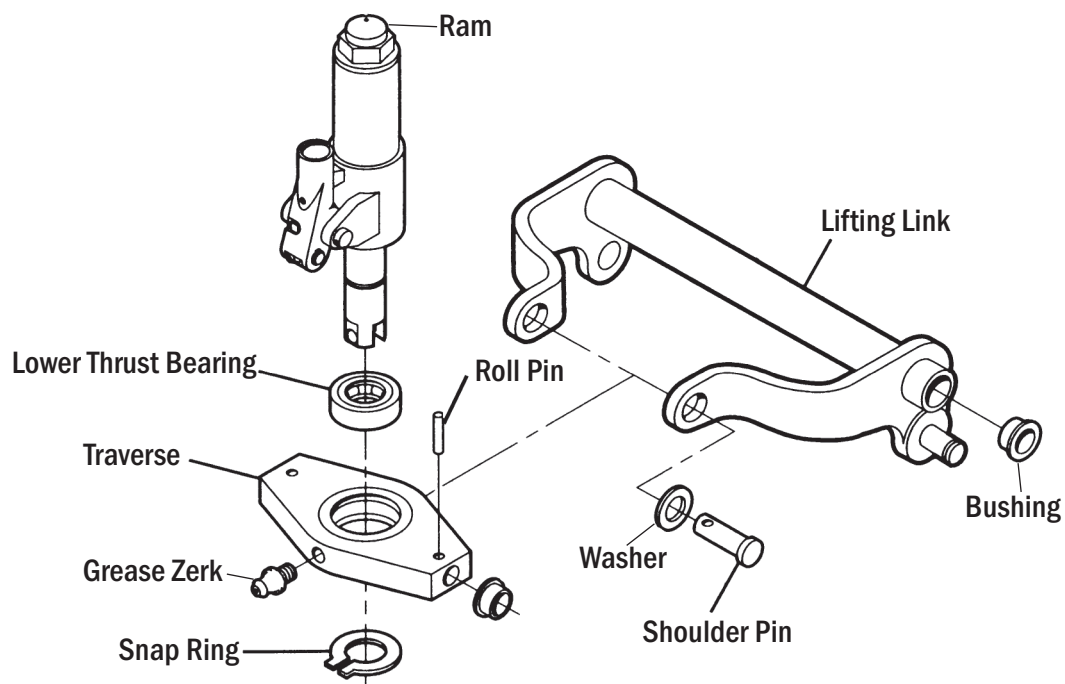

Push Rods

Inspection

When inspecting the push rods, look for broken or cracked welds, bends, missing roll pins and worn bushings. It is best to mark the position of the eyebolt and nut in relation to the push rod to ensure proper adjustment during installation.

Removal - T Series

Standard height - Fully lower the jack and then turn the jack over so that the undercarriage is facing up. Remove one of the snap rings on the pivot axle and drive the pivot axle out of the bracket and frame. Remove one of the snap rings on the push rod axle and drive the axle out of the bracket. Loosen the set screw holding the eccentric in the proper adjustment, remove the snap ring securing the eccentric to the lifting link and drive the eccentric out of the lifting link through the access hole in the frame. It is helpful to mark the adjustment of the eccentric for easier adjustment of the push rods during assembly.

(25 minutes)

Lowered height - Fully lower the jack and then turn the jack over so that the undercarriage is facing up. Drive out the roll pin fastening the pivot axle to the load roller bracket and remove the pivot axle. Drive the roll pin out that fastens the push rod axle to the load roller bracket and remove the axle. Unscrew the push rod from the eye bolt and remove the axle. Unscrew the push rod from the eye

bolt. It is helpful to mark the adjustment of the eye bolt for proper installation. (20 minutes)

Removal - E Series

Standard height - Fully lower the jack and then turn the jack over so that the undercarriage is facing up. Remove one of the snap rings on the pivot axle and drive the pivot axle out of the bracket and frame. Remove one of the snap rings on the push rod axle and drive the axle out of the bracket. Loosen the nut and unscrew the push rod from the eye bolt. It is helpful to mark the adjustment of the eye bolt for proper installation. (20 minutes)

Lowered height - Fully lower the jack and then turn the jack over so that the undercarriage is facing up. Drive the roll pin fastening the pivot axle to the load roller bracket out and remove the pivot axle. Drive the roll pin that fastens the push rod axle to the load roller bracket out and remove the axle. Unscrew the push rod from the eye bolt. It is helpful to mark the adjustment of the eye bolt for proper installation. (20 minutes)

E Series - Standard Height

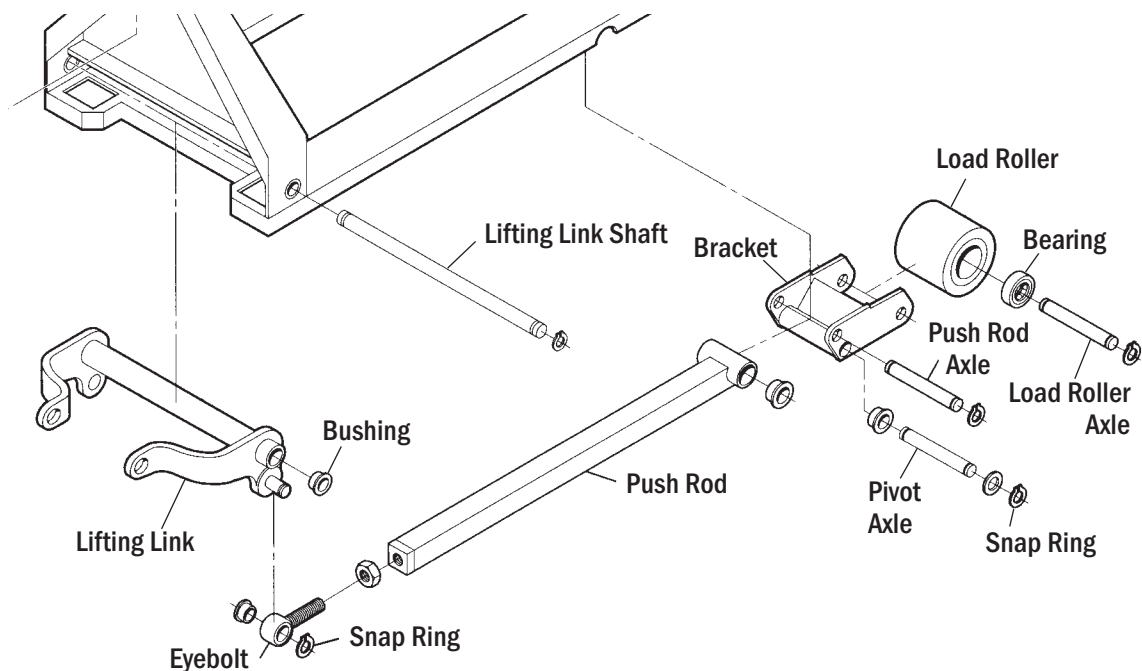

Push Rods

Installation - T Series

Standard height - Insert the eccentric through the lifting link and push rod. Secure it with its snap ring. Insert the push rod axle through the bracket and push rod. Secure with its snap rings. Slide the pivot axle through the frame and bracket.

Secure the axle in place with its snap rings.

Turn the jack upright and fully lower it. Adjust the push rod by turning the eccentric with a large screwdriver through the access hole on the side of the frame. By turning the eccentric you effectively lengthen or shorten the push rod.

Test the adjustment by pumping the jack up and then lowering it. If the forks hit bottom at the same time, then it is adjusted correctly. If one fork hits bottom before the other, then further adjustment is necessary.

Turn the eccentric about 1/8 to 1/4 of a turn and test the adjustment again. Once the push rods are adjusted correctly, turn the jack over onto its side and tighten the set screw down to keep the eccentric from turning. (30 minutes)

Lowered height - Thread the push rod onto the eye bolt and try to match the other side if it is still assembled. If it isn't, adjust the length after you have assembled the load roller bracket onto the push rod.

Insert the push rod axle through the bracket and push rod. Secure the axle in the bracket with the roll pin. Insert the pivot axle through the frame and bracket. Secure the axle in the bracket with the roll pin.

If you have not adjusted the push rod yet, place the lifting link in a position that matches a fully lowered position. Spin the push rod and bracket one way or the other until the pivot axle hole on the bracket lines up with the frame. Then insert and secure the pivot axle.

Test the adjustment by pumping the jack up and then lowering it. If the forks hit bottom at the same time, then it is adjusted correctly.

If one fork hits bottom before the other, then further adjustment is necessary. You can either shorten the push rod on the fork that hits first or lengthen the push rod on the fork that hits second.

It is easier if you do the adjustment on the eye bolt end once the load wheel bracket is attached to the frame. Remove one of the snap rings on the pin that fastens the eye bolt to the lifting link, and punch the pin out. Pull the eye bolt away from the lifting link and turn it one way or the other to adjust as needed.

Assemble the eye bolt and the lifting link with the pin and its

snap rings. Turn the jack over and test the adjustment. Keep adjusting until both forks hit bottom at the same time.

(25 minutes)

Installation - E Series

Standard height - Thread the push rod onto the eye bolt. Try to match the other side if it is still assembled. If it isn't, adjust the length after you have assembled the load roller bracket onto the push rod. Insert the push rod axle through the bracket and push rod. Secure the axle with the snap rings. Insert the pivot axle through the frame and bracket. Secure the axle in the frame with the snap rings.

If you have not adjusted the push rod yet, place the lifting link in a position that matches a fully lowered position. Spin the push rod and bracket one way or the other until the pivot axle hole on the bracket lines up with the frame. Then insert and secure the pivot axle.

Test the adjustment by pumping the jack up and then lowering it. If the forks hit bottom at the same time, then it is adjusted correctly. Turn the jack over onto its side and tighten the nut on the eye bolt up to the push rod to secure the adjustment during any other repairs. If one fork hits bottom before the other, then further adjustment is necessary. You can either shorten the push rod on the fork that hits first or lengthen the push rod on the fork that hits second. Keep adjusting until both forks hit bottom at the same time. (25 minutes)

Lowered height - Thread the push rod onto the eye bolt. Try to match the other side if it is still assembled. If it isn't, adjust the length after you have assembled the load roller bracket onto the push rod. Insert the push rod axle through the bracket and push rod. Secure the axle in the bracket with the roll pin. Insert the pivot axle through the frame and bracket. Secure the axle in the bracket with the roll pin.

If you have not adjusted the push rod yet, place the lifting link in a position that matches a fully lowered position. Spin the push rod and bracket one way or the other until the pivot axle hole on the bracket lines up with the frame. Then insert and secure the pivot axle.

Test the adjustment by pumping the jack up and then lowering it. If the forks hit bottom at the same time, then it is adjusted correctly. If one fork hits bottom before the other, then further adjustment is necessary. You can either shorten the push rod on the fork that hits first or lengthen the push rod on the fork that hits second. Keep adjusting until both forks hit bottom at the same time. (25 minutes)

Lifting Link

Inspection

Check lifting link for out-of-round holes, cracks in welds, or bent ears. If any of these conditions exist, replace the lifting link. We suggest that you work on one side of the jack at a time, so you can use the other side as a reference. The T Series standard height uses an eccentric for adjustment and the lowered height uses an eye bolt for adjustment. Both standard and lowered height of the E Series uses an eye bolt, as well.

Removal - T Series

Standard height - Pump the jack up to its maximum height. Remove the snap ring under the A-Frame that secures the upper thrust bearing assembly on the ram to the jack. Lift the jack off of the ram and pivot the hydraulic unit away from the frame. Remove the shoulder bolts fastening the traverse to the lifting link, by driving out their roll pins. Remove the hydraulic unit and traverse assembly as one piece. Turn the jack over so that the undercarriage is facing up. Loosen the set screw that holds the eccentric in adjustment. Remove the snap ring on the eccentric, and pull the eccentric out through the access hole in the side of the frame. Remove the snap ring on the lifting link shaft. Use a hammer and punch to drive the shaft out far enough to grip it on the other side, and pull it out. (45 minutes)
Lowered height - (see E Series Lifting Link Removal, below)

Removal - E Series

Standard and Lowered height - Pump the jack up to its maximum height. Remove the snap ring under the A-Frame that secures the upper thrust bearing assembly on the ram to the jack. Lift the jack off of the ram and pivot the hydraulic unit away from the frame. Remove the shoulder bolts, fastening the traverse to the lifting link, by driving out their roll pins. Remove the hydraulic unit and traverse assembly as one piece. Turn the jack over so that the undercarriage is facing up. Remove the pivot axle. Remove the snap ring on the axle for standard height jacks, or the roll pin on lowered height jacks. Then remove the eye bolt (with the push rod still attached) by removing the snap ring that fastens it onto the lifting link. Remove the snap ring on the lifting link shaft. Use a hammer and punch to drive the shaft out far enough to grip it on the other side, and pull it out. (45 minutes)

Lifting Link

Installation

Turn the jack over so that the undercarriage of the jack facing up, position the lifting link in the frame. Insert the lifting link shaft and secure it with its snap ring. Attach the push rod (see Push Rods) and the load roller bracket (see Load Roller Brackets). Turn the jack upright and install the traverse with the hydraulic unit and steer wheel assembly still attached (see Traverse). Position the ram and upper thrust bearing assembly into the A-Frame. Secure it with the snap ring. (45 minutes)

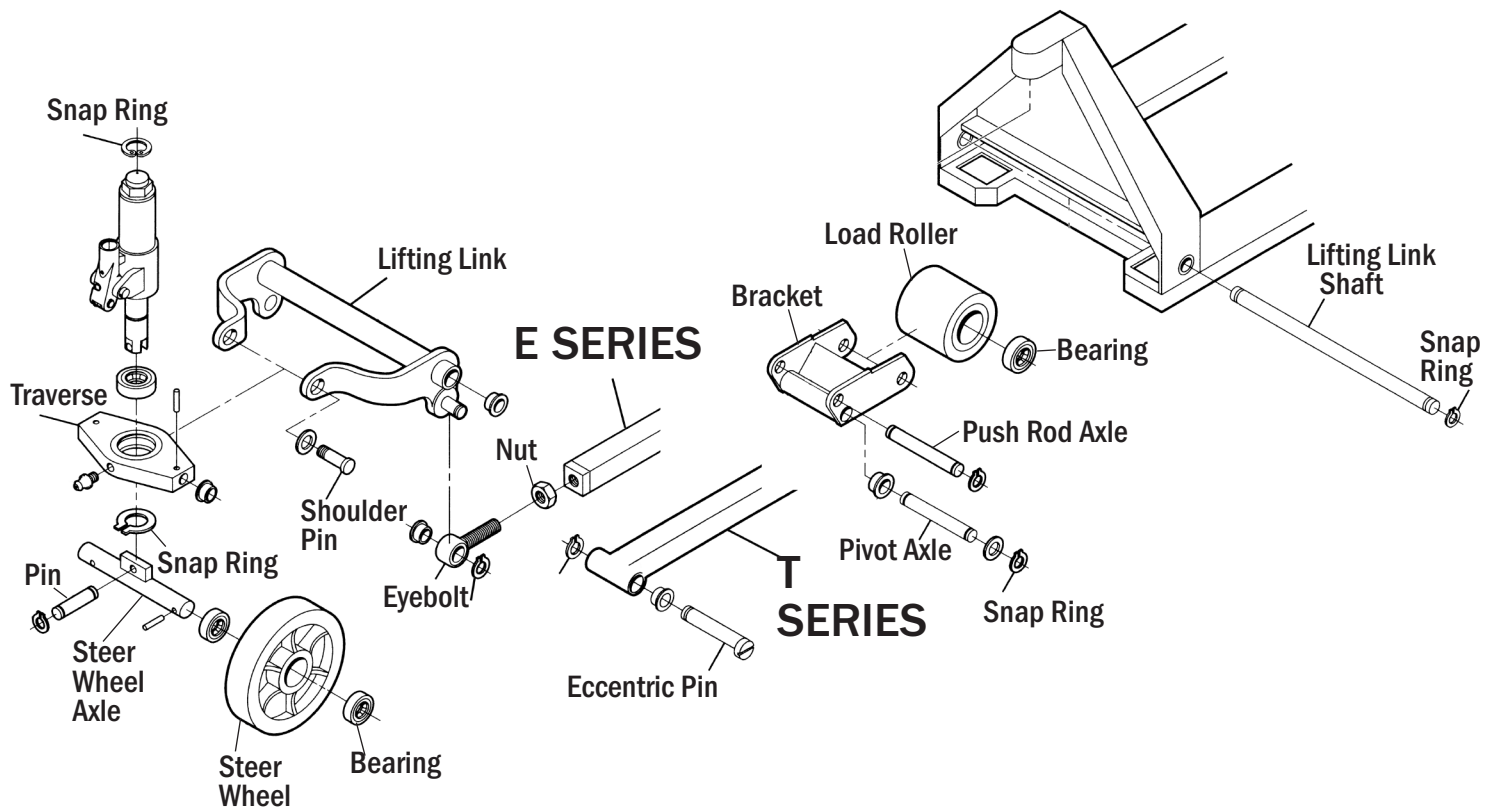

Handle Removal and Installation

Inspection

Inspect the handle for cracks and structural integrity. There should be minimal side play in the handle socket. Check for worn bushings. If bushings are not replaced regularly, the handle socket holes can become worn. This may require complete handle socket replacement to prevent unnecessary wear on mating parts. Also, inspect the pivot shaft and the piston pusher for wear. If any of the above parts are worn more than $1/16"$, replace them.

Foot Control Removal

Remove the roll pin. Pull up on the handle while twisting from side to side. (5 minutes)

Foot Control Installation

Insert the handle into the handle socket so the hole on the handle aligns with the hole in the handle socket. Drive the roll pin in place to secure the handle. (5 minutes)

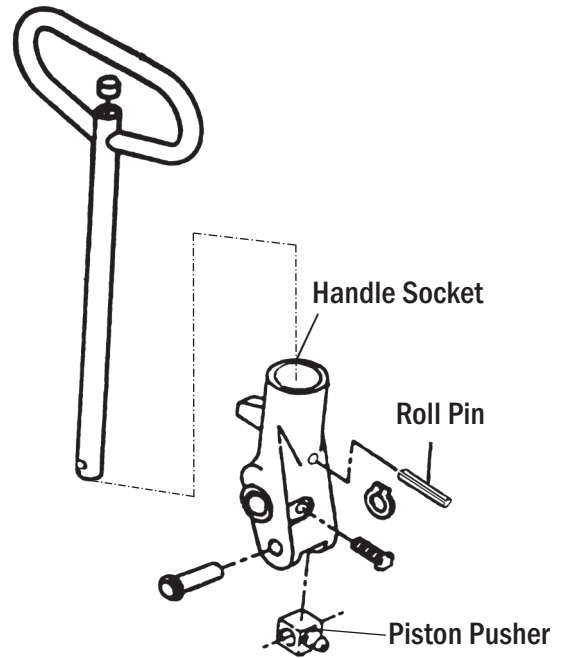

Newer Style

Hand Control Removal

Remove the locking nut and the adjustment screw in the fulcrum bar. This will allow the glide pin and the ball to slide out of the way, and allow room for the actuator to come out of the handle pivot shaft. Remove the handle bolt and carefully pull up on the handle to pull the actuator out of the handle pivot shaft. Do not twist the handle until the actuator is out of the handle pivot shaft. (5 minutes)

Hand Control Installation

Insert handle into handle socket so holes will align when completely inserted. While pushing the handle into the socket, the actuator must slide completely in the handle pivot shaft. Slide the ball and then the glide pin into the pivot shaft. Replace handle bolt. Install the adjusting screw and locking nut back into the fulcrum bar. (10 minutes)

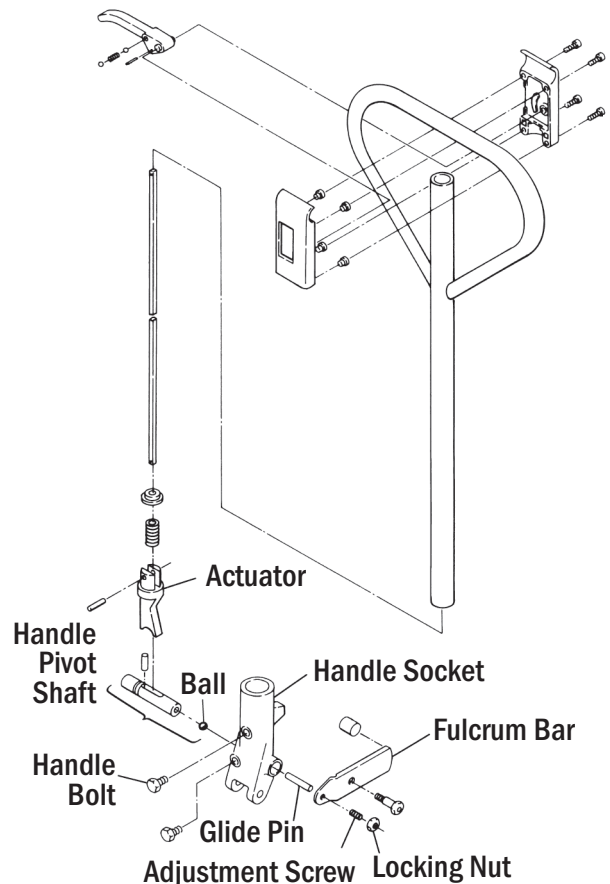

Hydraulic Unit

Inspection

Inspect the outside of the pump for oil leaks. Test the unit, under a load, to determine if there is a problem. This can be done by lifting a heavy pallet and letting it stand for 15-20 minutes. Below are symptoms and solutions to common hydraulic unit failures. If the following solutions fail to correct the problem, a complete rebuild of the malfunctioning unit may be necessary.

Jack fails to lift load

- **Air Lock in Pump (Foot or Hand Control)** - Place the control mechanism in the release position, then pump handle rapidly 10-15 times. (5 minutes)
- **Low Fluid Level (Foot or Hand Control)** - With the jack in a lowered position, remove filler plug slowly to avoid rapid depressurization. Using RL-HO oil, fill the reservoir until the oil is level with the fill plug hole. Replace filler plug, rotating no more than 360 degrees. Place the control mechanism in the lift position and pump the jack up to its maximum height. Remove filler plug to allow air into the reservoir, then replace the filler plug, creating a snug fit. Do not overtighten. (10 minutes)

NOTE: If lack of oil pressure is evident by short lifting strokes, repeat procedure. If failure is still evident, see Air Lock in Pump..

- **Hand Control Out of Adjustment** - Place hand control in neutral. Loosen the lock nut on the adjustment screw. Back the set screw out 3-4 turns, being careful not to completely remove it. Pump the handle slowly to raise the jack, then turn the adjusting screw in until the jack stops raising. Now turn the adjusting screw an additional $\frac{1}{4}$ of a turn and tighten the lock nut. Test the jack by placing the handle control in the neutral position, then pump the handle. The jack should not raise. Place the handle control in the lower position and the jack should lower. (see Diagram on page 12) (10 minutes)
- **Foot Control Malfunctioning** - If the foot control shoulder bolt is bent, replace it. If the foot control pedal is worn to the point that it is not properly engaging the actuator pin, replace the foot control pedal. If the foot control pedal appears to be properly engaging the actuator pin, the problem is probably within the hydraulic unit.

Jack fails to lower

- The foot control pedal shoulder bolt is loose or bent. Replace if necessary.
- The hand control may be out of adjustment (see *Hand Control Out of Adjustment*).
- Oil is too dense. Empty unit and refill with RL-HO oil.
- Look for any bent or damaged frame parts (lifting link, push rod, etc.). Bent or damaged frame parts should be replaced.
- Debris blocking an oil channel in the hydraulic unit. Contact us for our hydraulic core exchange program.

Jack lifts in short increments

- Loss of oil pressure - see *Low Fluid Level*.
- Reservoir filler plug leaking - Replace the washer and restore air pressure (see *Low Fluid Level*).

One fork lifts, the other does not

Check for damage in the following areas and their attached parts:

- Lifting link (lifting link pin and traverse shoulder pin)
- Pushrod
- Load roller bracket (pivot axle)

Hydraulic Unit

Service Hints

- Tampering and abuse are two of the most common problems. In most cases, minor repairs become major when inexperienced people attempt to rebuild a hydraulic unit. If you come across a unit that looks like it has been tampered with or modified, inspect the unit carefully to be sure it can be rebuilt or call Fast Lift Parts for technical assistance.
- The ram is chromed and the pump piston polished to a fine finish for maximum seal life and minimum oil leakage. If you see these surfaces nicked or pitted, this will cause the unit to fail in a short time. Replace any rusty or damaged parts that will cause premature wear on their mating parts or the body of the hydraulic unit.
- The high pressure relief valve is pre-adjusted by the factory and usually needs no attention.
- Use RL-HO hydraulic oil. Rol-Lift jacks use oil which is less dense than most pallet jack hydraulic oil.
Do not use automotive oil or hydraulic brake fluid.

Hydraulic Unit

Removal

Pump the jack to its maximum height and turn the jack onto its side. Remove the steer wheels and axle (see *Steer Wheels and Axle Removal*) and the snap ring under the traverse on the stem of the hydraulic unit. Turn the jack upright; be careful not to damage the stem of the hydraulic unit while lowering. Remove the snap ring securing the upper thrust bearing assembly on the ram to the A-Frame. Lift the frame off the ram, tip the handle and hydraulic unit away from the frame and rest both pieces on the ground. Pull the hydraulic unit out of the traverse and remove the handle if necessary (see *Handle Removal*). (45 minutes)

Installation

Slide the stem of the hydraulic unit into the traverse with the lower thrust bearing already in place on the stem. Insert the top of the ram and the upper thrust bearing assembly into the A-Frame and secure in place with the snap ring. Carefully turn the jack onto its side, keeping the hydraulic unit in the traverse and frame. Attach the snap ring to the stem of the hydraulic unit under the traverse. Install the steer wheel assembly (see *Steer Wheel and Axle Installation*) and the handle, if necessary (see *Handle Installation*). Bleed the hydraulic unit (see *Air Lock and Pump*). (45 minutes)

