

**Fast Lift Parts**



# Service Manual

## Blue Giant

Models PT-50 and PT-55

This manual is intended for basic service and maintenance of the Blue Giant pallet jack. The pallet jacks you are servicing are tools that make moving products easier. Operating pallet jacks with rusty, broken or worn parts makes usage and maintenance more difficult. Pallet jack parts are inexpensive and easy to replace. To ensure maximum life from the jack, always replace the parts that are broken or worn. Remember that all parts on a pallet jack depend on the adjoining parts to work properly and to perform to their full potential. When used in conjunction with our catalog, this service manual will explain how and when to replace a pallet jack part. Remember, when in doubt... replace it.

[www.FastLiftParts.com](http://www.FastLiftParts.com)

# Contents

<b>2</b>	<b>Suggested Assemblies</b>
<b>3</b>	<b>Commonly Used Tools</b>
<b>3</b>	<b>Helpful Reminders</b>
<b>4</b>	<b>Axles</b>
<b>4</b>	<b>Bushings</b>
<b>5</b>	<b>Load Rollers and Load Roller Brackets</b>
<b>6</b>	<b>Steer Wheels and Axle</b>
<b>7</b>	<b>Traverse</b>
<b>8</b>	<b>Push Rods</b>
<b>9</b>	<b>Lifting Link</b>
<b>10</b>	<b>Handle Removal and Installation</b>
	<b>Hydraulic Unit</b>
<b>11</b>	<b>Inspection</b>
<b>12</b>	<b>Service Hints</b>
<b>13</b>	<b>Removal</b>
<b>13</b>	<b>Installation</b>

Copyright © 2016 Fast Lift Parts. All rights reserved.

Blue Giant pallet jacks (all models) are products of Blue Giant Equipment Corp.

# Suggested Assemblies to Save Repair Time

- BG 805-603-Super  
Super Seal Kit
- BG 020-034-A  
Ultra-Poly Steer Wheel Assembly
- BG 300-027-A  
Ultra-Poly Steer Wheel Assembly
- BG 103-297-A-D-Super  
Super Ultra-Poly Load Roller Assembly
- BG 103-297-A-D  
Ultra-Poly Load Roller Assembly
- BG 103-297-A-Super  
Super Poly Load Roller Assembly
- BG 300-034-A  
Poly Load Roller Assembly
- BG 801-369  
Load Roller Bracket Assembly



# Commonly Used Tools

- Hammer
- Jack stand
- 24" Pipe wrench
- 7/16" Wrench
- 1/2" Wrench
- 9/16" Wrench
- 3/4" Wrench
- 15/16" Wrench
- 5/32" Allen wrench
- 3/16" Allen wrench
- 1/4" Allen wrench
- 1/8" Pin punch
- 1/4" Pin punch
- 3/8" Pin punch
- 5/16"-24 Bolt
- 45° Snap Ring pliers (large)
- Soft hammer (nylon mallet)
- Anti-seize compound
- Lubricant (i.e. WD40 may be necessary to remove rusted parts)

**PIN  
PUNCH**

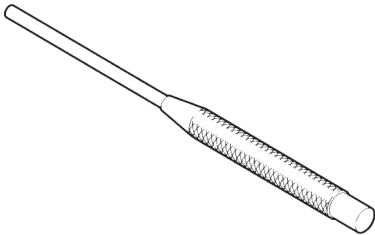

**BUSHING  
EXTRACTOR**

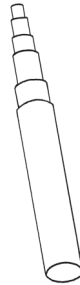

**SNAP RING  
PLIERS**

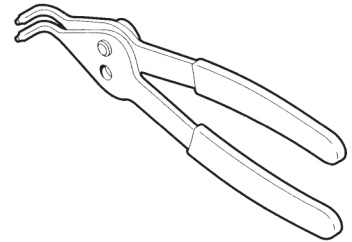

## Helpful Reminders

- Never hammer directly on an axle; always use a pin punch.
- Always replace old roll pins.
- Replace accessible bushings whenever the jack is disassembled.

# Axles

## Inspection

If the axle is bent, out-of-round, or shows signs of wear, replace it. Check for worn roll pin holes. If these are damaged or worn, replace the axle.

# Bushings

Bushings are designed to wear out sooner than the mating parts. They are made of softer material and are expendable. It is recommended that anytime the jack is torn down to a point where the bushings are accessible, they be replaced. This will ensure longer life of the jack and will reduce the amount of downtime. Bushings are very inexpensive and it is cost effective to change them regularly.

## Inspection

If bushings are cracked, broken, egg shaped or worn more than  $\frac{1}{16}$ " from the original size replace them.

**Remember:** If the jack is already disassembled, replace all accessible bushings.

*Tip: Coating axles and bushings with anti-seize compound before installation makes maintenance easier.*

# Load Rollers and Load Roller Brackets

## Inspection

**Load rollers** - Load rollers should not have flat spots or large pieces of metal imbedded in them (i.e. tacks, nails or metal shavings). Any chips in the wheel that keep it from rolling smoothly indicate the need for replacement. If the wheel has cracks, loose tread, or does not turn freely, replace both wheels. Always change the wheels in pairs to reduce uneven wear. New load rollers have an outside diameter of 2 <sup>3</sup>/<sub>4</sub>" (PT55) or 3" (PT50). If the diameter is worn more than 1/4" from normal size, replacement is necessary.

**Load roller brackets** - Inspect the brackets for cracks or wear from prolonged rubbing on the floor. Check for out-of-round axle holes and inspect the bushings closely (*see Bushing Inspection*). If any of the above conditions exist, replace the brackets.

## Removal

*Tip: We recommend servicing one load roller assembly at a time, while using the other assembly as a reference.*

**Load rollers** - Remove the roll pin from the load roller axle and drive out the load roller axle. (10 minutes)

**Load roller brackets** - Remove the load roller assembly, then the screw and nut which secures the pivot axle in place. Drive out the pivot axle, pull the push rod away from the frame, and pull the brackets off the push rod axle.

(15 minutes)

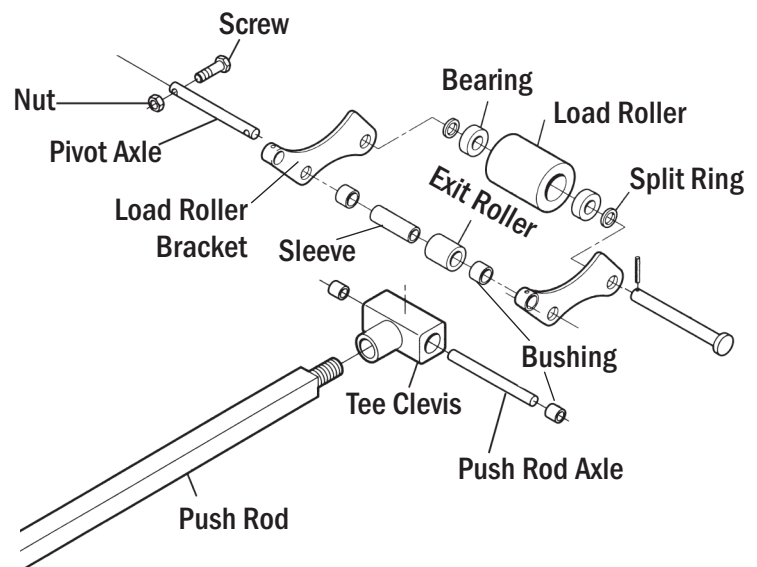

## Installation

**Load roller brackets** - Slide the brackets onto the push rod axle in the tee clevis. Insert the pivot axle through the frame, exit roller, sleeve and the brackets. Secure it with the screw and nut. Install the load roller axle through the brackets and roller, and secure the axle with its roll pin.

(15 minutes)

**Load rollers** - Place the wheel between the bracket and install the axle through the bracket and load roller, then install the roll pin. (10 minutes)

# Steer Wheels and Axle

## Inspection

Steer wheels should not have flat spots or large pieces of metal imbedded in them (i.e. tacks, nails or metal shavings). Chips in the wheel, which keep it from rolling smoothly, indicate the need for replacement. Steer wheels should turn freely. They should not rub the bottom of the traverse. If they do, check for the correct installation of the snap ring under the traverse. New steer wheels are 8" in diameter. If the wheel is worn more than 1/4" from the normal diameter, replacement is necessary.

## Removal

**Steer wheels** - Turn the jack onto its side. Pull the cotter pin out and slide the wheel off the axle. (10 minutes)

**Steer wheel axle** - Remove the steer wheels. Depending on the configuration, remove the roll pin or back the set screw off that secures the steer wheel axle in place. Some hydraulic units don't use any fasteners to hold the steer wheel axle in place. (15 minutes)

## Installation

**Steer wheel axle** - With the jack on its side, slide the axle into the stem of the hydraulic unit and secure with its fastener (if it has one), then install the steer wheels.

(15 minutes)

**Steer wheels** - Slide the wheel onto the axle and secure in place with the cotter pin.

(10 minutes)

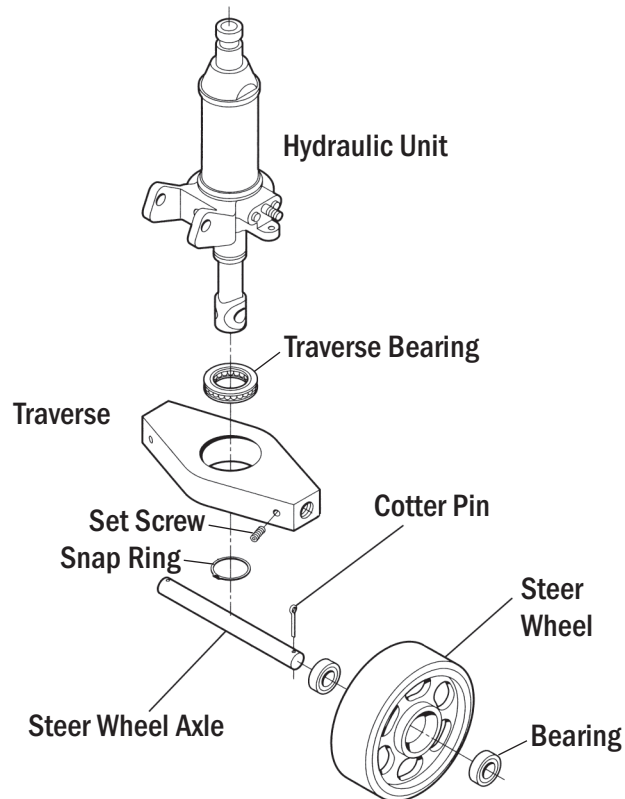

# Traverse

## Inspection

There are few things that can be wrong with the traverse. Wear can occur on the bearing shoulder or where the shoulder bolts attach to the lifting link. If these areas are egg-shaped or out of round, replace the traverse.

## Removal

Turn the jack onto its side so the weight is resting on the fork and the jack stand. Remove steer wheel and axle assembly

(see *Steer Wheels and Axle Removal*). Remove the snap ring under the traverse on the stem of the hydraulic unit. Carefully turn the jack upright. Remove the screw that fastens the ram to the frame. Lift the frame off of the ram and pull the hydraulic unit out of the traverse. Loosen the set screws that secure the shoulder bolts in place, and remove the shoulder bolts and the traverse. (20 minutes)

## Installation

Attach the traverse to the lifting link with the shoulder bolts and tighten the set screws. Position the thrust bearing on the traverse. Slide the hydraulic unit into the traverse. Insert the top of the ram into the A-Frame and secure it with the screw. Turn the jack over onto its side and install the snap ring that holds the traverse in place on the stem of the hydraulic unit. Install the steer wheel axle and steer wheels (see *Steer Wheels and Axle*).

(20 minutes)

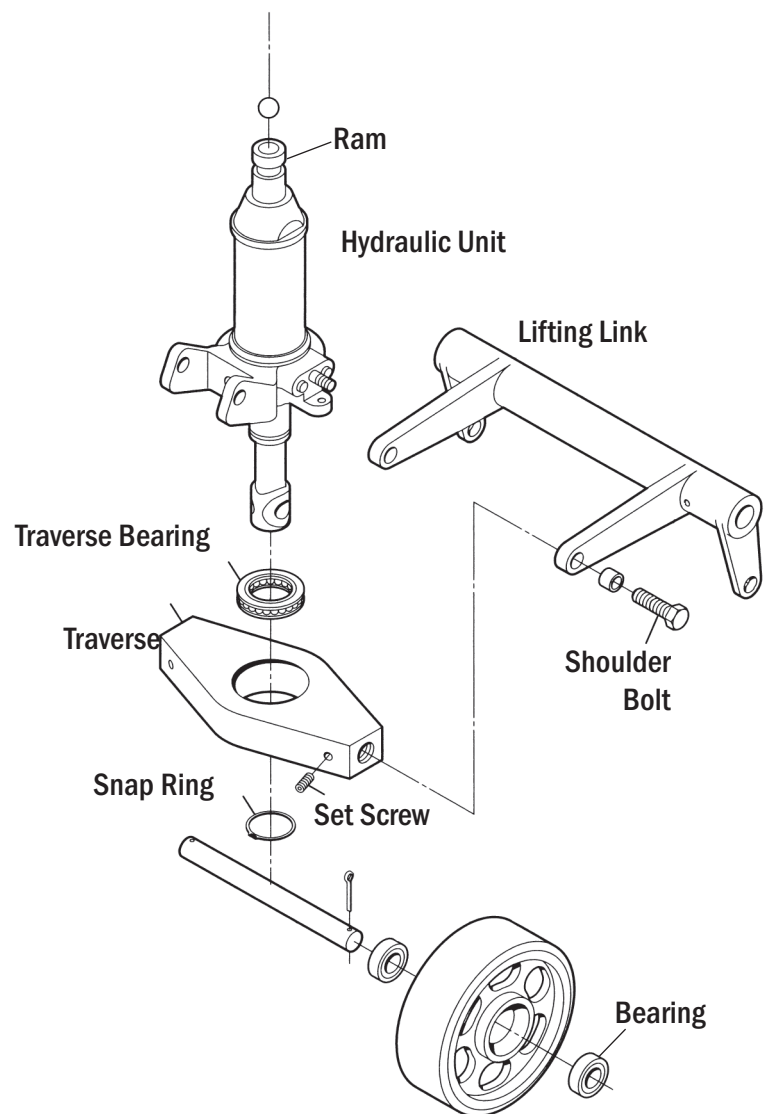



# Push Rods

## Inspection

When inspecting the push rods, look for broken or cracked welds, bends, and out-of-round holes. If any of the above conditions exist, replace the push rod. We suggest that you work on one side of the jack at one time, so you can use the other side as a reference.

## Removal

Turn the jack over so the undercarriage is facing up. Drive the roll pin out of the pin connecting the lifting link to the push rod. Remove the pin and unscrew the push rod from the tee clevis. It is helpful to mark the adjustment of the tee clevis for proper installation. **(10 minutes)**

## Installation

Fully lower the pallet jack and turn it over so that the undercarriage is facing up. Thread the push rod into the tee clevis to the point that the holes of the push rod line up with the lifting link and insert the pin that attaches the two parts. Drive in the roll pin to secure the pin in place. To ensure the push rods are adjusted correctly, turn the jack over to its normal operating position. Then raise the jack and stand on the forks, facing the handle. While standing on the forks, lower the jack and determine if both forks bottom-out at the same time. If one reaches the floor before the other, adjustments are needed. You can shorten the adjustment on the fork that hit second or lengthen the adjustment on the fork that hit first. **(15 minutes)**

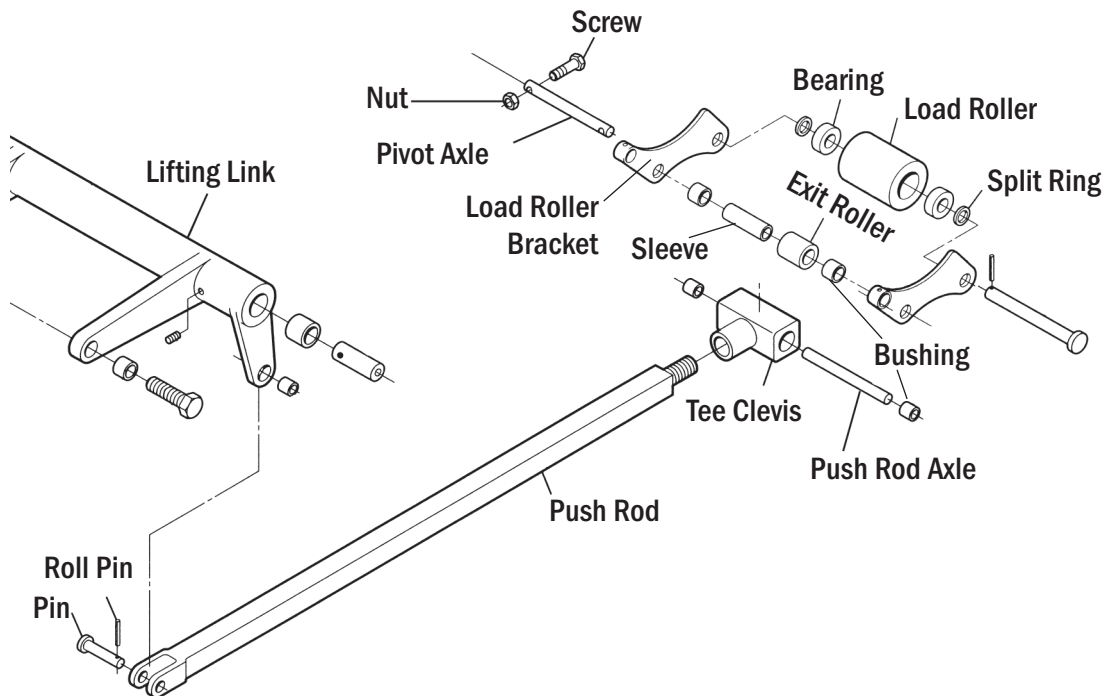

# Lifting Link

## Inspection

Check lifting link for out-of-round holes, cracks in welds, or bent ears. If any of these conditions exist, replace the lifting link. Also, look for worn bushings, missing shoulder bolts, missing lifting link pins or the roll pins that fasten these parts to their mating parts.

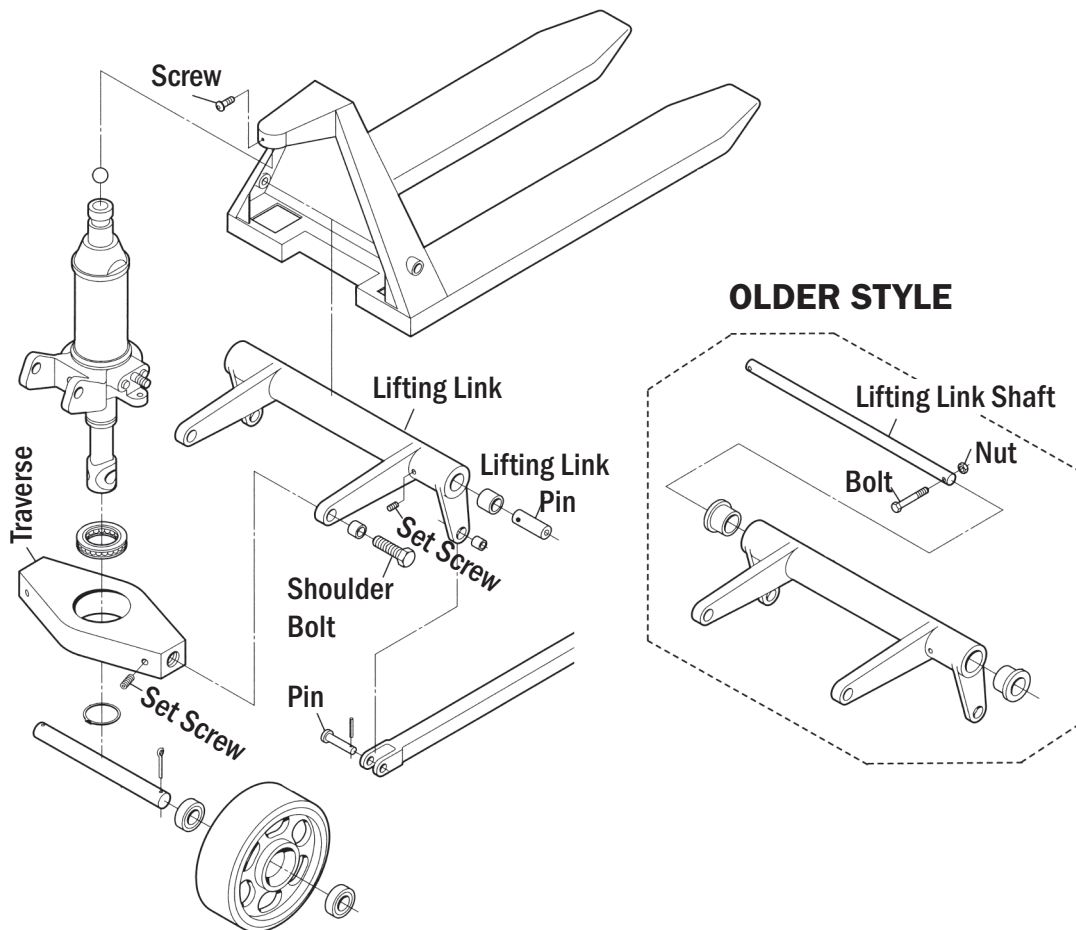

## Removal

Remove the screw in the top of the A-Frame that fastens the ram to the jack. Remove the set screws and shoulder bolts that fasten the traverse to the lifting link. Remove the pump, traverse and steer wheel assembly as one unit. Turn the jack over so that the undercarriage is facing up. Remove the pins that attach the push rod to the lifting link (*see Push Rod Removal*). Remove the set screws that secure the lifting link pins in place. The interior of the lifting link pins are threaded for a  $\frac{5}{16}$ "-24 bolt. Screw in a  $\frac{5}{16}$ "-24 bolt into the lifting link pin and pull the pin out using the bolt. The old style lifting link uses one long shaft held by a bolt and nut at one end. Remove the nut and bolt, punch the shaft through far enough to get a hand on it and pull it free of the jack. (45 minutes)

## Installation

Turn the jack over so that the undercarriage is facing up. Position the lifting link into the frame so the holes line up with the holes in the frame. Install the lifting link pins and set screws. Attach the push rods (*see Push Rods*). Secure the traverse (with the pump and steer wheels still attached), with the shoulder bolts and their set screws. Fasten the top of the ram to the frame with the screw. (45 minutes)

# Handle Removal and Installation

## Inspection

Inspect the handle for cracks and structural integrity. There should be minimal side play in the handle bracket. Check for worn bushings. If bushings are not replaced regularly, the handle bracket holes can become worn. This may require complete handle bracket replacement to prevent unnecessary wear on mating parts. Also, inspect the handle pin and roller for flat areas and wear. If any of the above parts are worn more than  $\frac{1}{16}$ " , replace them.

## Foot Control Removal

Remove the bolts fastening the handle to the handle bracket and the handle will slide out. If you need to remove the bracket, remove the roll pin fastening the handle pin in place. Remove the handle pin so the bracket can be removed. Be careful to retain the pump piston in the hydraulic unit. (10 minutes)

## Foot Control Installation

Place the handle bracket into position on the hydraulic unit. Insert the handle pin and secure it with a roll pin. The handle can then be inserted into the handle bracket and secured with the nuts and bolts.

(15 minutes)

## Hand Control Removal

Remove the handle and handle bracket together. Remove the screw that holds the handle pin in place and remove the handle pin. The handle bracket assembly can now be removed. Be careful to keep the pump piston in place when removing the handle assembly.

To remove the handle from the bracket, remove the nut fastening the release lever to the bracket. Pull the release lever free from the control rod. Remove the nuts and bolts holding the handle and bracket together, and the handle will come free. (10 minutes)

## Hand Control Installation

Attach the handle assembly to the brackets with the nuts and bolts. Slide the release lever into the lower end of the control rod. Place the handle assembly into position on the hydraulic unit. Insert the handle pin through the hydraulic unit and handle assembly. Secure with the screw. (15 minutes)

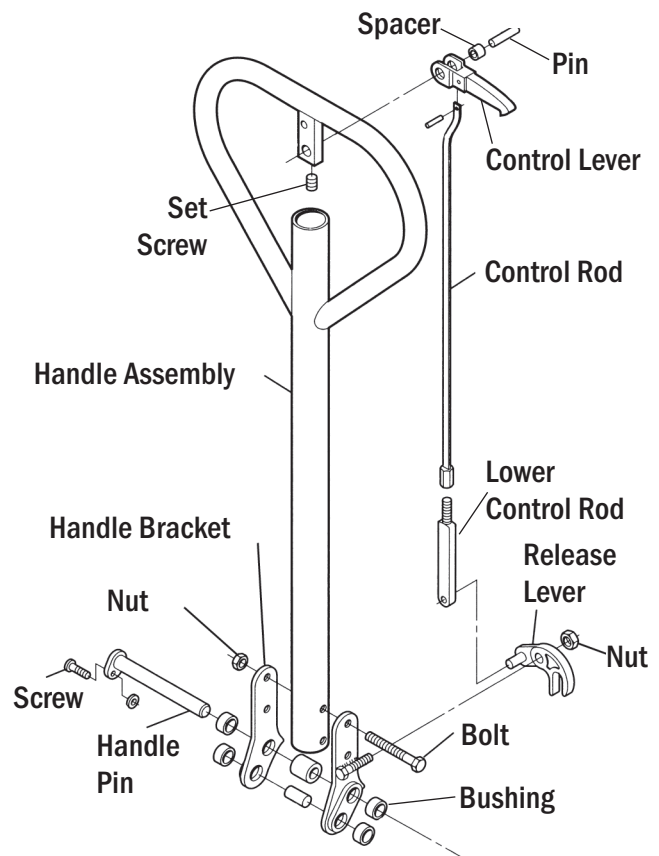
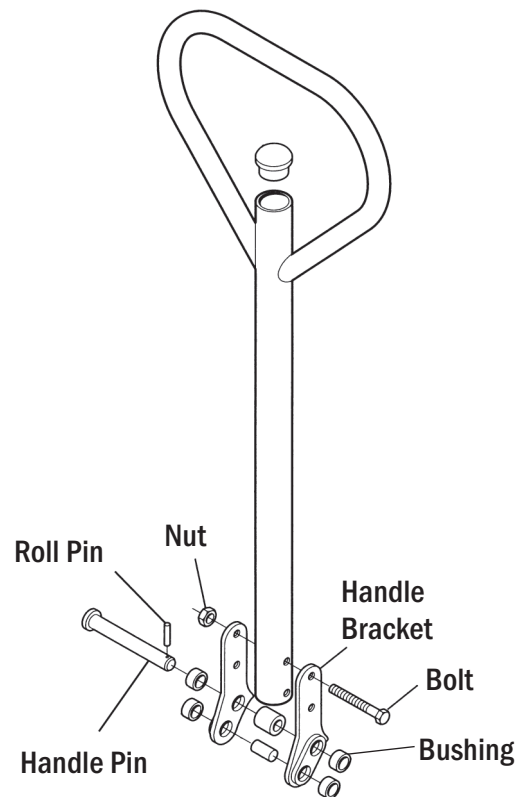

# Hydraulic Unit

## Inspection

Inspect the outside of the pump for oil leaks. Test the unit, under a load, to determine if there is a problem. This can be done by lifting a heavy pallet and letting it stand for 15-20 minutes. Below are symptoms and solutions to common hydraulic unit failures. If the following solutions fail to correct the problem, send the unit to us. If the following solutions fail to correct the problem, a complete rebuild of the malfunctioning unit may be necessary. Please refer to our catalog for information about ordering the appropriate seal kit, or take advantage of our hydraulic unit exchange program.

## Jack fails to lift load

- **Air Lock in Pump** - Place the control mechanism in the release position, then pump handle rapidly 10-15 times. (5 minutes)
- **Low Fluid Level (Foot or Hand Control)** - With the jack in a lowered position, remove filler plug. Using UNI-HO oil, fill the reservoir until the oil is level with the fill plug hole. Bleed the unit (*see Air Lock in Pump*). Replace the filler plug, creating a snug fit. Do not over-tighten. (5 minutes)
- **Hand Control Out of Adjustment** - Pull the plastic cover off the stud that the pedal plate rides on. Loosen the first nut in order to adjust the second nut. Adjusting the second nut in or out will affect how soon the hydraulic unit goes into release and neutral. The pedal plate should be touching the valve pins. When the pedal plate is pressing the valve pin farthest away from the pump piston, the unit should be in neutral. When the pedal plate is pressing in the valve pin nearest to the pump piston, the unit should be in release. (5 minutes)
- **Foot Control Malfunctioning** - Pull the plastic cover off the stud that the foot pedal rides on. Loosen the first nut to adjust the second nut. The foot pedal should have  $\frac{3}{4}$ " of free play before the release pin is engaged. The valve pins should be in contact with the pedal in all positions. (5 minutes)

## Jack fails to lower

- Look for any bent or damaged frame parts (lifting link, push rod, etc.). Bent or damaged frame parts should be replaced.
- Foot or hand control is out of adjustment (*see Hand Control Out of Adjustment or Foot Control Malfunctioning*).
- Debris blocking an oil channel in the hydraulic unit. Contact us for our hydraulic core exchange program.

## Jack lifts in short increments

- Lack of oil pressure - *see Low Fluid Level*
- Reservoir filler plug leaking - Replace the washer and filler plug and replenish oil, if necessary (*see Low Fluid Level*).

## One fork lifts, the other does not

**Check for damage in the following areas and their attached parts:**

- Lifting link (lifting link pin and traverse shoulder pin)
- Pushrod
- Load roller bracket (pivot axle)

# Hydraulic Unit

## Service Hints

- Tampering and abuse are two of the most common problems. In most cases, minor repairs become major when inexperienced people attempt to rebuild a hydraulic unit. If you come across a unit that looks like it has been tampered with or modified, inspect the unit carefully to be sure it can be rebuilt or call Fast Lift Parts for technical assistance.
- The ram is chromed and the pump piston polished to a fine finish for maximum seal life and minimum oil leakage. If you see these surfaces nicked or pitted, this will cause the unit to fail in a short time. Replace any rusty or damaged parts that will cause premature wear on their mating parts or the body of the hydraulic unit
- Use UNI-HO hydraulic oil.  
*Do not use automotive oil or hydraulic brake fluid.*

# Hydraulic Unit

## Removal

Pump the jack to its maximum height and turn the jack onto its side. Remove the steer wheels and axle (see *Steer Wheels and Axle Removal*) and the snap ring under the traverse on the stem of the hydraulic unit. Turn the jack upright; be careful not to damage the stem of the hydraulic unit while lowering. Remove the screw that fastens the top of the ram to the frame. Lift the frame off of the ram, tip the handle and hydraulic unit away from the frame, and rest both pieces on the ground. Remove the ball on top of the ram and pull the hydraulic unit out of the traverse. Remove the handle and handle bracket if necessary (see *Handle Removal*). (45 minutes)

## Installation

Slide the stem of the hydraulic unit into the traverse with the traverse bearing already in place on the stem. Insert the ram into the A-Frame with the ball positioned on the top of the ram and secure the ram to the A-Frame with the screw. Carefully turn the jack onto its side, keeping the hydraulic unit in the traverse and frame. Attach the snap ring to the stem of the hydraulic unit under the traverse. Install the steer wheel assembly (see *Steer Wheel and Axle Installation*) and the handle, if necessary (see *Handle Installation*). Bleed the hydraulic unit (see *Air Lock and Pump*). (45 minutes)

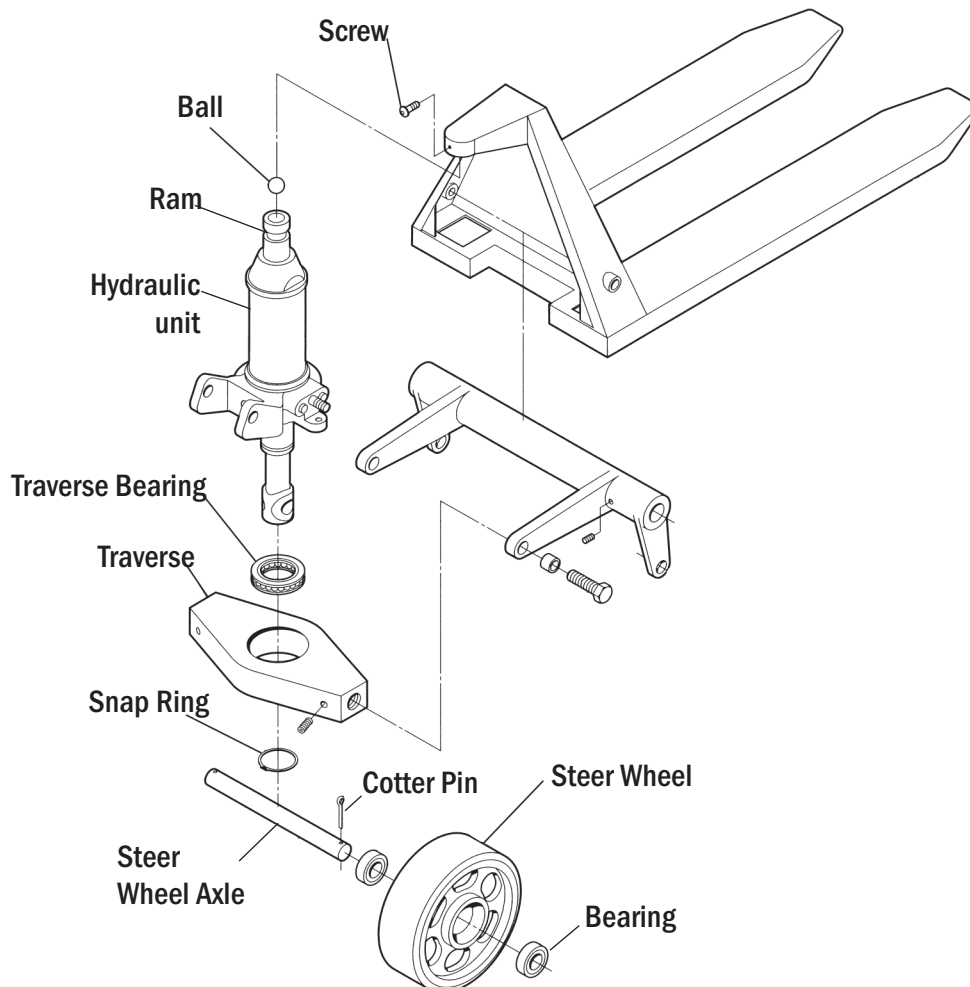

***Fast Lift Parts***