

INSTALLATION INSTRUCTIONS

ALWAYS READ & UNDERSTAND ALL INSTALLATION INSTRUCTIONS BEFORE COMMENCING

THIS INSTRUCTIONS APPLIES TO THE FOLLWING PRODUCTS:

WASD25-1 SERIES MODEL# WASD250101B LINEAR SLOT DIFFUSER (AT VARIOUS LENGTHS)

STEP 1

Thoroughly clean the diffuser surface with a clean cloth free from residue and oil contaminates. A clean surface would enhance the bonding between the diffuser and the drywall compound.



STEP 2:

Install the diffuser by applying dry wall screw **along the perimeter** of the diffuser, we recommend each fastener to be 6" apart. There are no pre-drilled holes on the surface, the installer should choose the initial location of the surface mount drywall screws based on the site condition.



STEP 3:

After fastened the drywall screws on the surface, locate the pre-drilled hole at each internal end of the slot. Apply a self-tapping sheet metal screws penetrating the plenum for a firm hold.

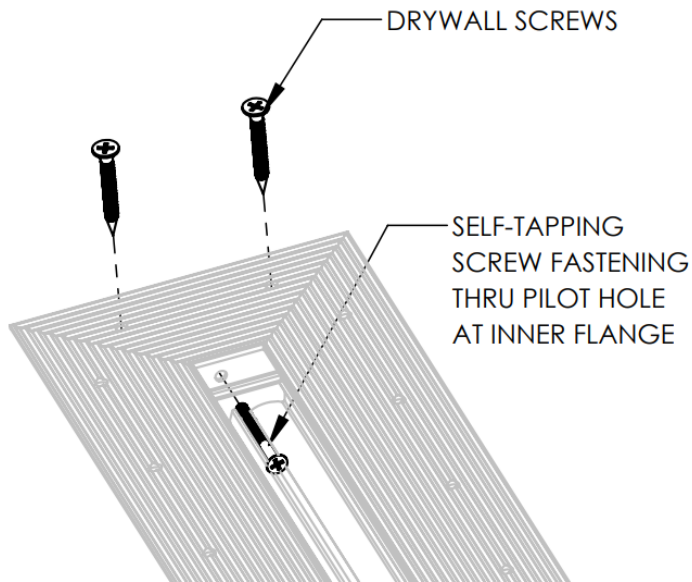

STEP 4:

Apply one coat of dry wall compound on the diffuser flanges and approximately 3" on to the drywall that extends beyond the diffuser's frame



STEP 5:

Apply a 4" wide mesh of paper tape to joint the compound. A smooth wrinkle free surface should be observed. The mesh or tape should not block the diffuser air passageway, it should only be covering the boundaries of the diffuser and the dry wall where the seam is located. **(Tip: lightly moisten the paper tape before applying would enhance the surface finish)**



STEP 6:

Apply another layer of dry wall compound, covering the mesh or tape as well as other areas on the diffuser that requires additional dry wall compound for smoothing the surface. Then set dry as per manufacture's instructions.

Step 7:

Apply at least two coats of finishing compound. Once the compound is dried, sand down with a wall sanding tool until smooth before painting.

