



Red 4 User Manual



Red 4 Manual

Rev: 1.1.0

Four Door Controller - **Part Number: R4**

Table of Contents

[Package Contents](#)

[Specifications](#)
[Wiring](#)

[Installation](#)
[Compliance Information](#)

[Connections](#)

Package Contents

The **Red 4 Controller** comes standard with Ethernet as well as an onboard power supply that is built into the controller. Optional wireless and PoE modules are also available and may be purchased separately.



Red 4
Four Door Controller (1)



Can Lock (1)



Battery Leads (1)

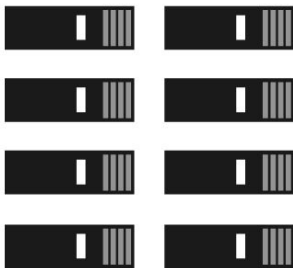

Jumpers (8)

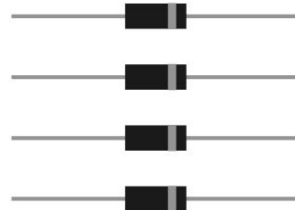

Diode (4)

- **Red 4 Controller**
- Battery Leads (1)
- Jumpers (8)
- Diodes (4)
- Labels (4)
- Enclosure Screws (2)
- QuickStart Guide (1)

Specifications

[Connections](#)
[Enclosure](#)

[Communication Options](#)
[Weight](#)

[Environmental](#)
[Compliance](#)

Connections

- Removable screw-down terminals
- Polarized DC-only Power Supply Input
- Industrial-grade 2Amp Form-C Relays (4 Relays)
- Reader Input (4)
- Input A (4)
- Input B (4)
- Additional power and ground connections for devices other than door connectors

Communication Options

- Ethernet
- WiMAC wireless mesh (2.4 GHz / 802.15.4)
- Encryption: AES 128-bit
- Wireless Range: 1-mile line of sight / 450 ft. indoor average

Environmental

- Temperature: -20°C ~ +60°C / -4°F ~ +140°F
- Humidity: 0%–95% relative humidity noncondensing

Enclosure

- Dimensions (W x H x D) 10.4375" x 7.625" x 3"
- Metal lockable security can (indoor use only)

Weight

- 3 Lbs.

Compliance

- Conforms to UL 294

Installation

This section of the manual provides instructions for installing the ProdataKey **Red 4** controller. Before you begin the installation, read the instructions thoroughly. Make sure you have read and understood the Safety Information.

WARNING: Disconnect power before working with the ProdataKey product. **DO NOT** mount the product while power is applied. Always apply power at the *end* of the installation after verifying wiring connections are correct; incorrect wiring could cause damage to the product.

IMPORTANT: A ProdataKey **Cloud Node** is required to operate the **Red 4** controller.

[Pre-Installation Requirements](#)

[Mounting Instructions](#)

[Power / Battery](#)

[Battery Maintenance, Replacement, & Disposal](#)

Pre-Installation Requirements

Power

- 12V–24V DC Input
- 12 VDC 5 Amp 60 Watt Class-2 power supply (Input supply to the board)
- Powers readers and other door hardware directly from the bus

Recommended Tools

- Drill and the appropriate size drill bit
- Phillips / Slotted screwdriver (to match screw heads)
- Wall anchors (2) if mounting to drywall
- Pencil (to mark hole positions on the mounting surface)
- Wire crimper/stripper

Mounting Instructions

- Mount the **Red 4** controller at the door/device or as centrally located as possible.
- Install the **Red 4** and Cloud Node in an environmentally controlled and secure area.

These instructions allow you to easily fasten the box properly and securely to a wall surface. Prior to beginning, ensure you have the package contents, tools, and necessary materials for the installation on an appropriate surface (i.e., drywall, wood).

- Use the **Red 4** box to mark the hole positions on the wall, and drill holes into the surface. If mounting onto drywall, insert the anchors into the holes to secure the screws to the surface.
- Align the enclosure's holes to the holes in the wall surface and mount the controller box with the screws so the box is securely fastened to the wall.

Power / Battery

Using a battery that meets the following specifications will provide at least 30 minutes of backup power in the event of an AC power loss:

- **Recommended Battery Type:** 12 VDC 8 Ah lead-acid battery
- **Recommended Battery Size:** 4" x 3.5" x 3" (L H W)
- **Max Battery Dimensions:** 6" x 5" x 4" (L H W)

A backup battery is **HIGHLY** recommended to prevent system failure in the event of an AC power loss. When a backup battery is not used, a loss of AC power will cause a loss of output voltage. A backup battery must be installed in order to comply with UL 294.

Add the 12V DC 8 Ah battery, attaching the wires from the battery to the circuit board battery terminal (illustration below).

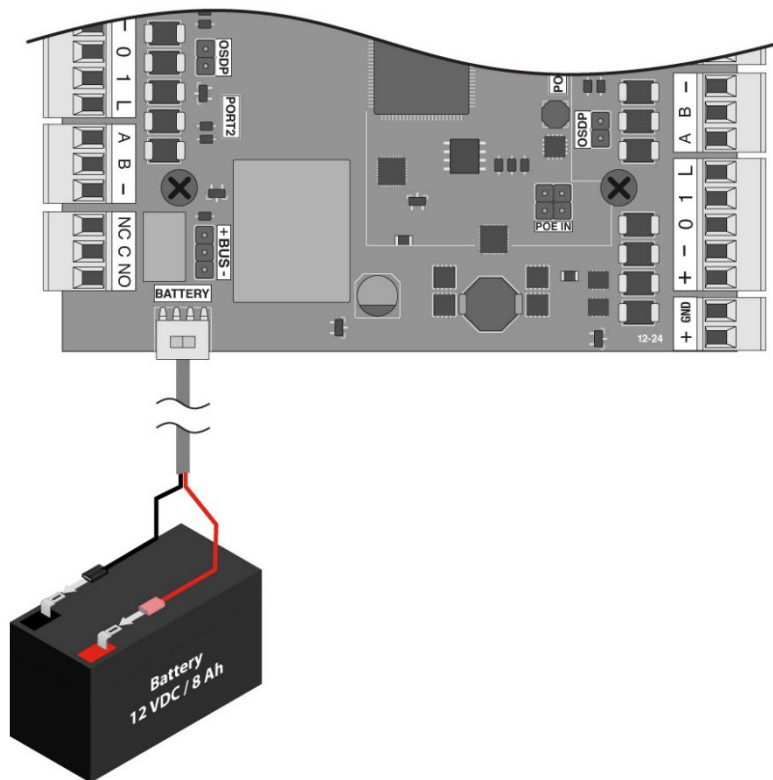

The onboard power supply is a 12.0V 5A 60-watt, class-2 power supply. This connection is polarity sensitive, meaning that it has fixed positive and negative connections. From the onboard

power supply, connect a red 18/2 wire from the positive (+) DC terminal to the positive (+) Cloud Node connector. Connect a black 18/2 wire from the onboard power supply negative (-) DC terminal to the negative (-) Cloud Node connector (A/1 in the illustrations above).

NOTE: DO NOT connect the backup battery until ALL wiring is completed and verified; incorrect wiring could cause damage to the product.

For information about connecting other wires, such as power wires to third-party locks, readers, and other devices, see the respective manufacturers' instructions.

Battery Maintenance, Replacement, & Disposal

The Red 4 controller features a battery charger and constantly monitors the battery's health and statistics.

Check the battery regularly and replace it only with an identical battery or a ProdataKey recommended battery. Dispose of used batteries according to local regulations or the battery manufacturer's instructions.

IMPORTANT: There is a risk of a battery explosion if the battery is incorrectly replaced.

Connections

[Board Overview](#)

[Connectors](#)

[Board Systems LED
Indicators](#)

Board Overview

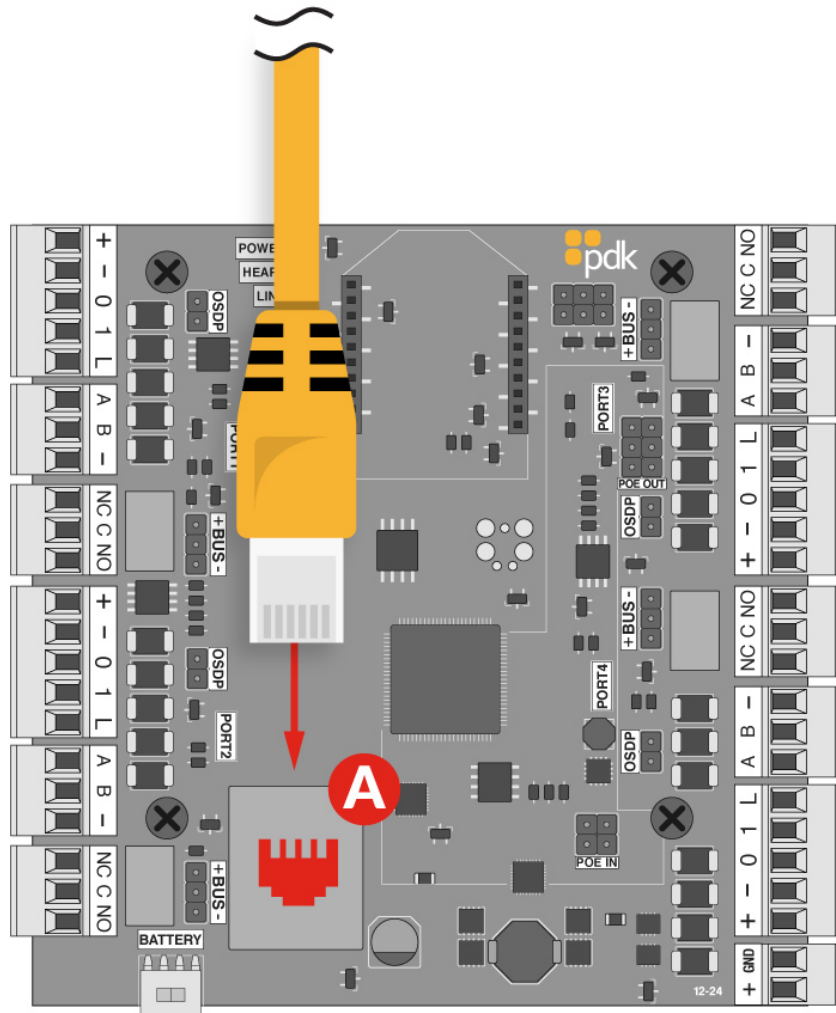

Legend

(+)	Positive	A	DPS Input	NC	Normally Closed
(-)	Ground	B	REX Input	C	Common
0	Reader Data 0	(-)	Ground	NO	Normally Open
1	Reader Data 1				
L	Reader LED Trigger				

Standard Ethernet Board (A) - An Ethernet connection is the standard default **Red 4** communication option.

Connectors

This section describes the Red 4 connector's technical specifications.

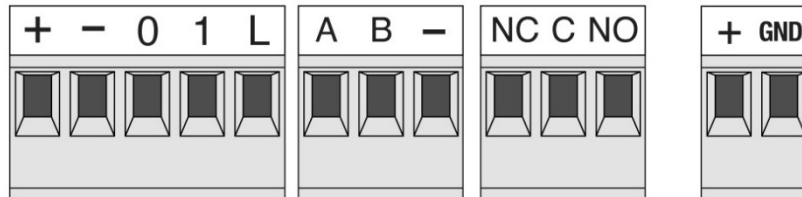

The voltage end connector will be 12/24VDC.

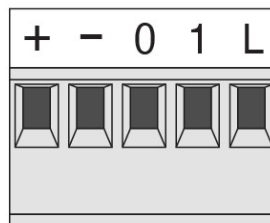

5-Pin Connector	Port	PIN	Notes
Power Output	+	1	Positive 12VDC Out
Power Output	-	2	Negative 12VDC Out
Reader Data	0	3	Input Data 0 / OSDP B
Reader Data	1	4	Input Data 1 / OSDP A
Reader LED Trigger	L	5	Reader LED Output Trigger

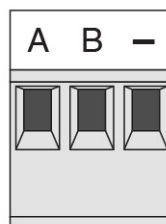

3-Pin Connector	Port	PIN	Notes
------------------------	-------------	------------	--------------

DPS Input	A	1	Door Position Switch (or assignable in programming).
REX Input	B	2	Request to Exit (or assignable in programming).
Ground	-	3	Ground

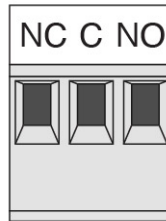

3-Pin Connector	Port	PIN	Notes
Normally Closed	NC	1	Normally closed connection for main form C relay with optional jumper configuration for wet positive (+) or negative (-) output.
Common	C	2	Common connection for main form C relay.
Normally Open	NO	3	Normally open connection for main form C relay with optional jumper configuration for wet positive (+) or negative (-) output.

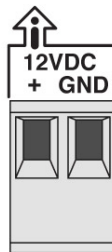

2-Pin Connector	Port	PIN	Notes
Controller Power Input	+	1	12/24 VDC Positive
Controller Power Input	GND	2	12/24 VDC Negative

Important Note: Power into the **Red 4 Controller** board is polarity-sensitive, meaning that it has fixed positive and negative connections.

Board Systems LED Indicators

LED indicators are shown on the controller board for POWER, HEART, LINK, and ethernet LEDs located on the ethernet port.

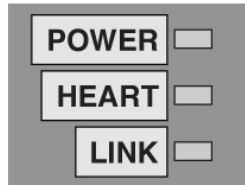

LED	Light	Status
POWER	On	Board is powered up
POWER	Off	No power to board.
HEART	Flashing	Normal operation.
HEART	Solid On	Possible serious hardware function. Call Support.
LINK	Solid On	No connection.
LINK	Solid Off	The connection is good.
Ethernet Speed	Orange	The connection is communicating at 100mbps
Ethernet Speed	Green	The connection is communicating at 1000mbps/1gbps
Ethernet Activity	Off	There is no connection to a network through the cable.
Ethernet Activity	Green	There is an active connection to a network through the cable.

When a relay is triggered, an LED near the appropriate relay will turn on, showing the relay has changed state.

Wiring

[Recommended Wiring Dimensions](#)

[Diode Setup](#)

[Reader Connectors](#)

[Door Position Sensor \(DPS\) Wiring Diagram](#)

[Maglock/Exit Device Wiring Diagram](#)

[Fail-Secure Door Strike Wiring Diagram](#)

[Fail-Safe Door Strike Wiring Diagram](#)

NOTE: For UL-certified wire installations, all wire running from a **Red 4** door controller to a lock, strike, or reader device must be less than 98.5 feet (30 meters).

- Strip the wire ends as required.
- Install the reader, and attach the wires, meeting your reader configurations.
- Connect the wires between the door controller and locks and any other devices.

Recommended Wiring Dimensions

Use 26 gauge minimum, 18 gauge maximum, stranded for general wiring. Wiring methods shall be in accordance with the National Electrical Code, ANSI/NFPA 70. Follow these recommended wiring sizes.

Wiring For	Recommended Size
Power Input	18 gauge 2 conductors (18/2) wire
Reader	22 gauge 6 conductors (22/6) wire
Strike / Maglock	18 gauge 2 conductors (18/2) wire
REX	18 gauge 4 conductors (18/4) wire
OSDP Reader	22 gauge 4 conductors Twisted-Pair (22/4) wire

Diode Setup

A diode is a standard semiconductor device integral to the safe and proper function of the door controller. It acts as a grounding tool, allowing the flow of current in one direction only. When a door strike is called/requested/sent, the coil sends a spike (also called “kickback voltage”) down

the line with as much as 50,000 volts. Without a diode semiconductor, this kickback voltage would damage the control equipment. When properly installed, the diode keeps kickback voltage localized at the lock.

To protect your equipment against electrical kickback, the diode must be installed across the DC-powered lock, at the strike, between positive (+) and ground (-). DC voltage is polarized, meaning that it has fixed positive and negative connections. The diode must be installed in the direction shown in the illustrations: gray stripe to positive (+), black to negative or ground (-).



Reader Connectors

This section describes the Red 4 connector's technical specifications.

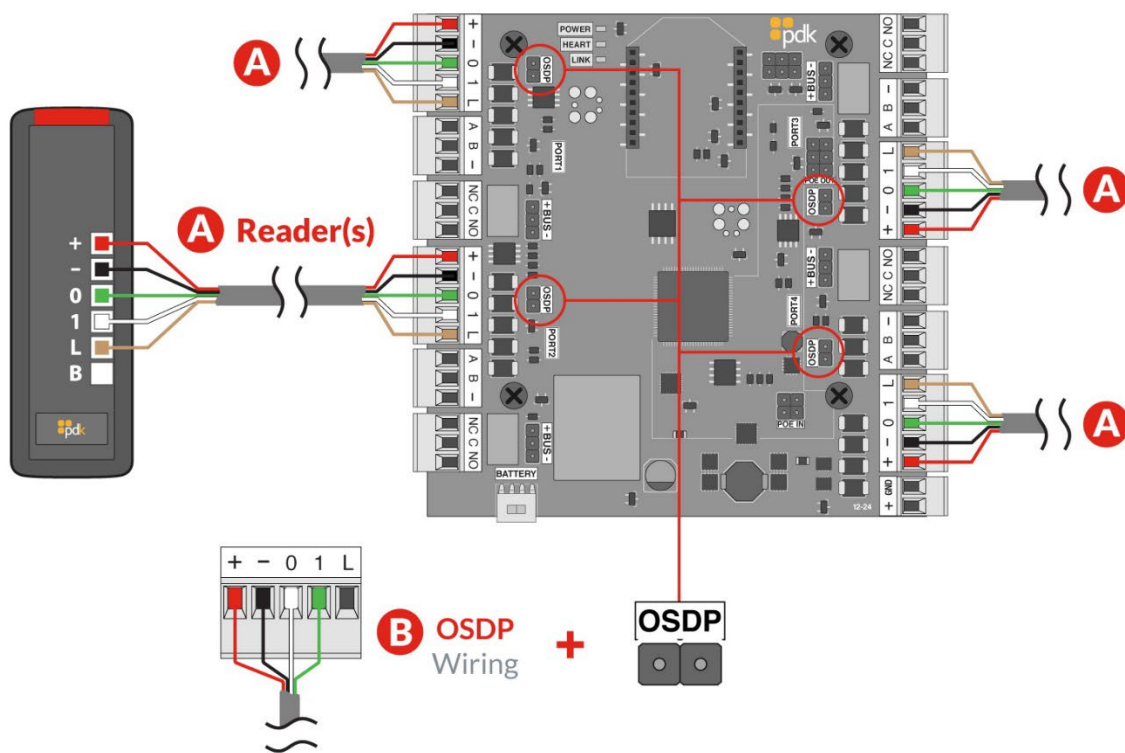

(A) Readers - The reader is mounted at the door with a 22/5 or 22/6 wire ran to the door controller. Wire the reader to the controller as shown above. Be sure to check polarity and voltage prior to powering the controller.

(B) OSDP - Place jumper(s) to enable OSDP multi-drop capabilities

(A) DPS: The Door Position Sensor is mounted on the door frame in the desired location with a 22/2 wire running from the DPS to the controller. (When using two DPS sensors for double doors, wire them in series with only two conductors running back to the controller.)

(B) Input A: Rule-based inputs can be triggered by using the (A) input for something other than DPS.

NOTE: When input receives a negative (-) connection from the controller, the input is triggered until the negative is dropped. A rule can be set up to trigger any output based on this input trigger.

Maglock/Exit Device Wiring Diagram

A magnetic lock, or maglock, is a locking device that consists of an electromagnet and an armature plate. Locking devices can be either "fail-safe" or "fail-secure". The electromagnet portion of the lock is typically attached to the door frame; a mating armature plate is attached to the door. The two components are in contact when the door is closed. When the electromagnet is energized, a current passing through the electromagnet causes the plate to attract the electromagnet, creating a locking action.

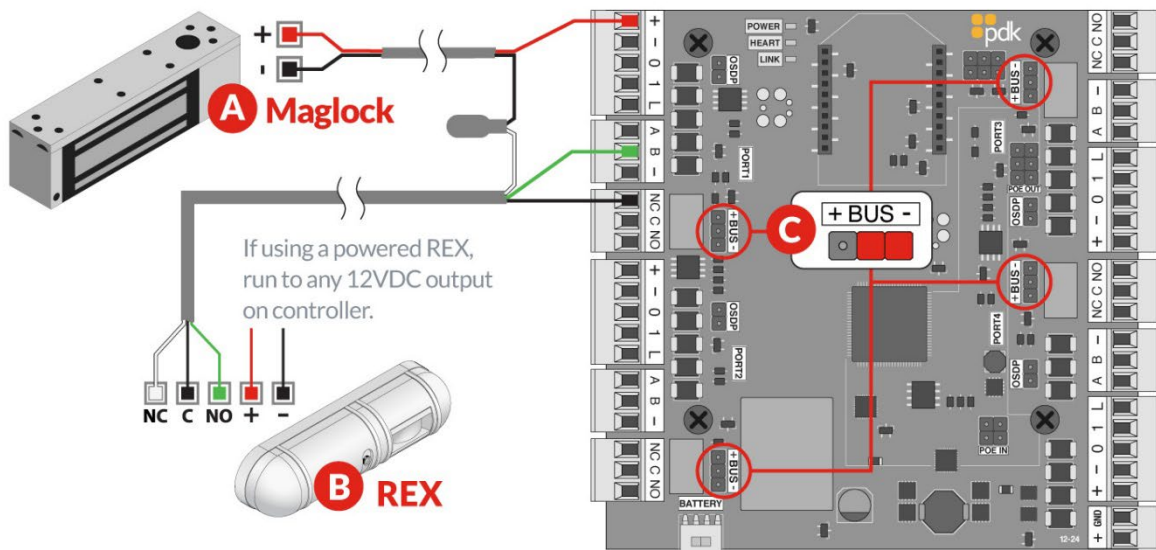

NOTE: For UL-certified wire installations, all wire running from a door controller to a lock, strike, or reader device must be less than 98.5 feet (30 meters).

(A) Maglock: When installing a maglock, it is required to install an electronic REX (request to exit) device as well as a mechanical button at the same door (in case of electrical failure) for free egress. Run 18/2 wire connections from the maglock to the door controller.

(B) REX/Exit Device: Mounted in the desired location with 18/5 wire running from the REX to the controller (18/3 wire if non-powered REX). Wire the REX to the controller and maglock. If using a powered REX, run to any 12VDC output on the controller. If reporting functionality is not needed in the system, simply eliminate the green wire.

(C) Jumper: Use the designated positive (+) or negative (-) board voltage out of (NO) and (NC). If the jumper is off, the relay is a standard “dry contact” needing input into common. In this diagram, the jumper is placed on the top (-) and center pin to operate the maglock.

Fail-Secure Door Strike Wiring Diagram

A fail-secure locking device remains locked when power is lost. An electric strike replaces the fixed strike faceplate often used with a latch bar. It normally presents a ramped surface to the locking latch allowing the door to close and latch just like a fixed strike.

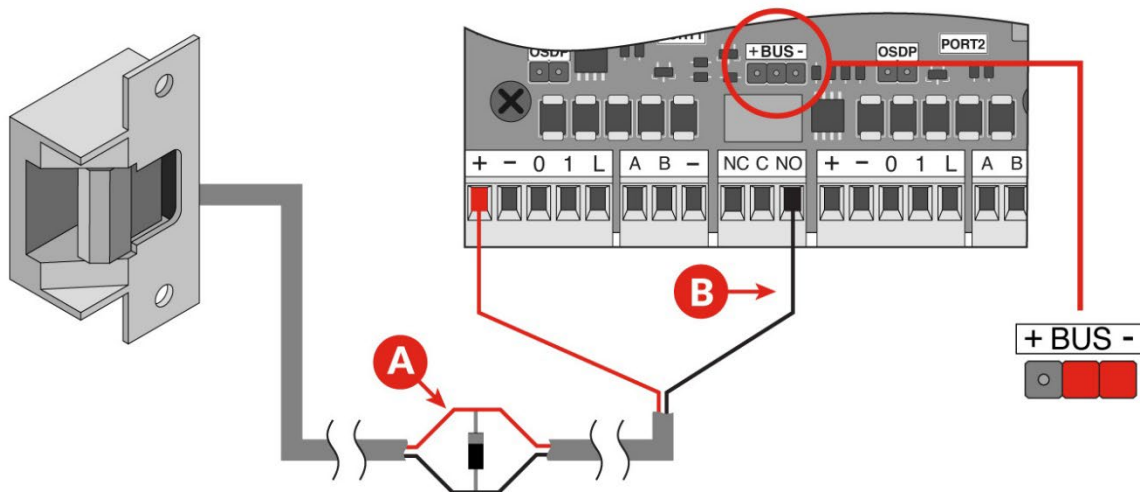

(A) Diode: The provided diode MUST be installed when using a strike. Install at the strike with the stripe of the diode on positive (+) and the black on negative (-).

IMPORTANT: The diode MUST be installed as close to the lock as possible. The best scenario (if possible) is directly across the screw terminals on the lock. Another option is to splice the diode in parallel (shown in the image above), connecting it to the positive (+) and negative (-) strike wires using dolphin connectors, and crimp the wires.

(B) NO: Normally Open - Used for strikes in fail-secure configuration. Connect the negative (-) of the strike to NO (Normally Open) on the door controller.

Jumper: Use the designated positive (+) or negative (-) board voltage out of (NO) and (NC). If the jumper is off, the relay is a standard “dry contact” needing input into common. In this diagram, the jumper is placed on the negative (-) and center pin to operate the strike.

Fail-Safe Door Strike Wiring Diagram

A fail-safe locking device unlocks when power is lost. An electric strike replaces the fixed-strike faceplate often used with a latch bar. It normally presents a ramped surface to the locking latch allowing the door to close and latch just like a fixed strike.

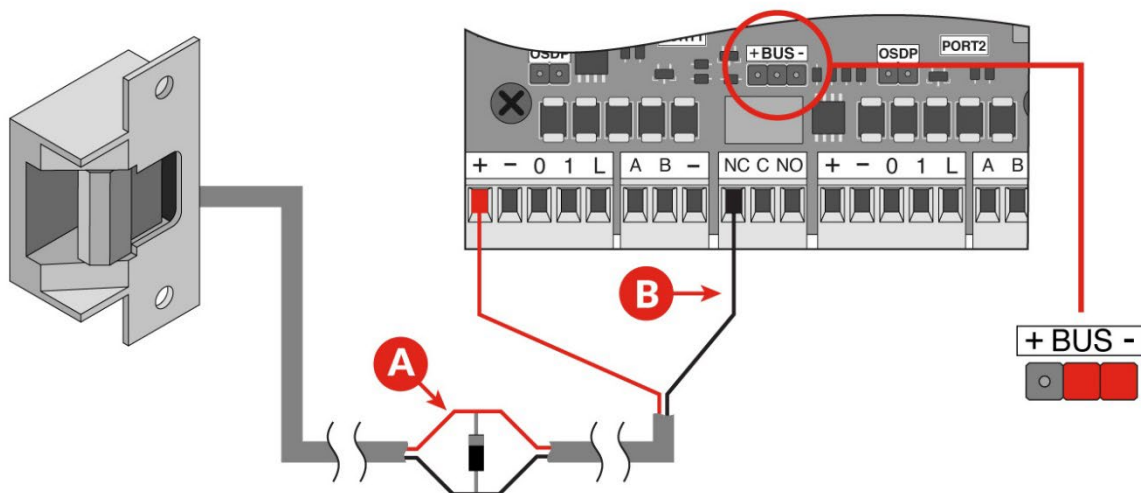

(A) Diode: The provided diode MUST be installed when using a strike. Install at the strike with the stripe of the diode on positive (+) and the black on negative (-).

IMPORTANT: The diode MUST be installed as close to the lock as possible. The best scenario (if possible) is directly across the screw terminals on the lock. Another option is to splice the diode in parallel (shown in the image above), connecting it to the positive (+) and negative (-) strike wires using dolphin connectors, and crimp the wires.

(B) NC: Normally Closed - Used for strikes in fail-secure configuration. Connect the negative (-) of the strike to NC on the door controller.

Jumper: Use the designated positive (+) or negative (-) board voltage out of (NO) and (NC). If the jumper is off, the relay is a standard “dry contact” needing input into common. In this diagram, the jumper is placed on the negative (-) and center pin to operate the strike.

Compliance Information

[Notices](#)
[Intellectual
Property Rights](#)

[FCC Compliance](#)
[Hardware Notices](#)
[Safety](#)

[UL 294 Notices](#)
[Trademark Acknowledgments](#)
[Disposal and Recycling](#)

[Liability](#)
[Regulatory
Information](#)

Notices

- The ProdataKey **Red 4** Door Controller is intended for indoor use only.
- The ProdataKey product shall be installed by a trained professional.
- The ProdataKey product shall be used in compliance with local laws and regulations.
- Mount in a dry, well-ventilated, secure environment. Do not install the door controller box on unstable brackets, surfaces, or walls.
- Use only applicable tools when installing the ProdataKey product. Using excessive force while mounting the product could cause damage.
- Avoid exposing ProdataKey product to shocks or heavy pressure.
- Do not use chemicals, caustic agents, or aerosol cleaners to clean the product. Use a clean cloth dampened with pure water for cleaning the exterior of the enclosure.
- Use only accessories that comply with the technical specification of the product. These can be provided by ProdataKey or a ProdataKey authorized third-party vendor.
- Use only spare parts provided by or recommended by ProdataKey Support or a product reseller.
- Do not attempt to repair the product by yourself. Contact ProdataKey Support or your ProdataKey authorized distributor for service matters.
- Protect the power cord, Ethernet cable, and transformer wires from being walked on or pinched, particularly where the wiring exits the box.

FCC Compliance

FCC Compliance Statement: This device complies with Part 15 of the FCC rules. Operation is subject to the following two conditions:

1. This device may not cause harmful interference.
2. This device must accept any interference received, including interference that may cause undesired operation.

Product can be used without license conditions or restrictions in all European Union countries, including Austria, Belgium, Denmark, Finland, France, Germany, Greece, Ireland, Luxembourg, The Netherlands, Portugal, Spain, Sweden, and the United Kingdom, as well as other non-EU countries, including Iceland, Norway, and Switzerland.

UL 294 Notices

- The ProdataKey product shall be installed within a secured area.
- A backup battery is required for UL 294 installations.
- A UL 294 listed direct plug-in power supply with a “power ON” indication is required with the following ratings: 12 VDC 5 Amp 60 Watt. The power supply shall be visible after installation and located within 6 feet from the panel. The power supply ratings need to match the ratings of the non UL 294 listed power supply that was tested with the panel.
- All cable runs to the door controllers must be less than 98.5 feet (30 meters).
- Do not connect the power supply Transformer to a receptacle controlled by a switch.
- Use a can lock to ensure secure enclosures and prevent tampering.
- The wiring shall be in accordance with the National Electrical Code, ANSI/NFPA 70.

Section 8:

Feature	Level
Destructive Attack Level	II
Line Security	II
Endurance Level	IV
Standby Power	II

Liability

ProdataKey makes no warranty of any kind with regard to the material contained within this document, including, but not limited to, the implied warranties of merchantability and fitness for a particular purpose. ProdataKey shall not be liable, nor responsible for incidental or consequential damages in connection with the furnishing, performance, or use of this material. This product is only to be used for its intended purpose.

Every care has been taken in the preparation of this document. Please feel free to inform ProdataKey Support of any inaccuracies or omissions in this documentation. We welcome your feedback and suggestions. ProdataKey cannot be held responsible for any technical or typographical errors and reserves the right to make changes to the product and documentation without prior notice.

Intellectual Property Rights

Patents Pending - ProdataKey has intellectual property rights relating to technology embodied in the product described in this document.

Hardware Notices

This equipment must be installed and used in strict accordance with the instructions given in the user documentation. This equipment contains no user-serviceable components. Wiring methods shall be in accordance with the National Electrical Code, ANSI/NFPA 70. Unauthorized equipment changes or modifications will invalidate all applicable regulatory certifications and approvals.

Use only accessories that comply with the technical specification of the product. These can be provided by ProdataKey or an approved third party. Use only spare parts provided by or recommended by ProdataKey.

After the system is installed and working properly, no further maintenance or testing is required.

Do not attempt to repair the product by yourself. Contact ProdataKey Support or your ProdataKey authorized distributor for service matters.

Trademark Acknowledgments

ProdataKey, Prodata Key, prodatakey, PDK, Prodata, are registered trademarks or trademark applications of ProdataKey in various jurisdictions. All other company names and products are trademarks or registered trademarks of their respective companies. Permission to use, copy, modify, and distribute this software and its documentation for any purpose with or without fee is hereby granted, provided that the copyright notice appears in all copies and that both the copyright notice and this permission notice appear in supporting documentation.

Regulatory Information

Electromagnetic Compatibility (EMC)

This equipment has been designed and tested to fulfill applicable standards for

- Radio frequency emissions when installed according to the instructions and used in its intended environment.
- Immunity to electrical and electromagnetic phenomena when installed according to the instructions and used in its intended environment.

Safety

This manual has been prepared to help you install the product. Read through the installation instructions carefully before installing the product. Keep the guide for future installation and maintenance reference.

This product complies with IEC/EN/UL 60950-1, Safety of Information Technology Equipment. If your connecting cables are routed outdoors, the product shall be grounded either through a shielded network cable (shielded twisted pair) or another appropriate method.

The power supply used with this product shall fulfill the requirements for Safety Extra Low Voltage (SELV) and Limited Power Source (LPS) according to IEC/ EN/UL 60950-1.

Disposal and Recycling

When this product has reached the end of its useful life, dispose of it according to local laws and regulations. For information about your nearest designated collection point, contact your local authority responsible for waste disposal. In accordance with local legislation, penalties may be applicable for incorrect disposal of this waste.

Supported Readers

Most Wiegand and OSDP readers are compatible with the ProdataKey hardware. For information regarding the ProdataKey readers, see the available product data sheets at [ProdataKey Readers](#)

PDK Certification and Tutorials

Visit ProdataKey [accesscontrol101.com](https://www.prodatakey.com/accesscontrol101.com) for certification training and tutorials.

Manufacturer's Limited Warranty

One to three-year warranty against defects in materials and workmanship. Full details at <https://www.prodatakey.com/warranty>.

Support / Sales

Technical Support

- **Phone:** 801.317.8802 option #2
- **Email:** support@prodatakey.com
- **Direct Dealer Support Line:** 801.206.4086

Sales:

- **Phone:** 801.317.8802 option #1
- **Email:** sales@prodatakey.com

Copyright

© 2022 ProdataKey, LLC. All rights reserved. ProdataKey, the ProdataKey logo, the Red logo and other ProdataKey marks are owned by ProdataKey, LLC and may be registered. All other trademarks are the property of their respective owners. ProdataKey assumes no responsibility for any errors that may appear in this manual. Information contained herein is subject to change without notice.

Red 4 Door Controller Instruction Manual

ProdataKey Door Controllers

Ver. 1.1.0

Date: October 2022