

AM/FM STEREO RECEIVER

SX-450

SERVICE MANUAL

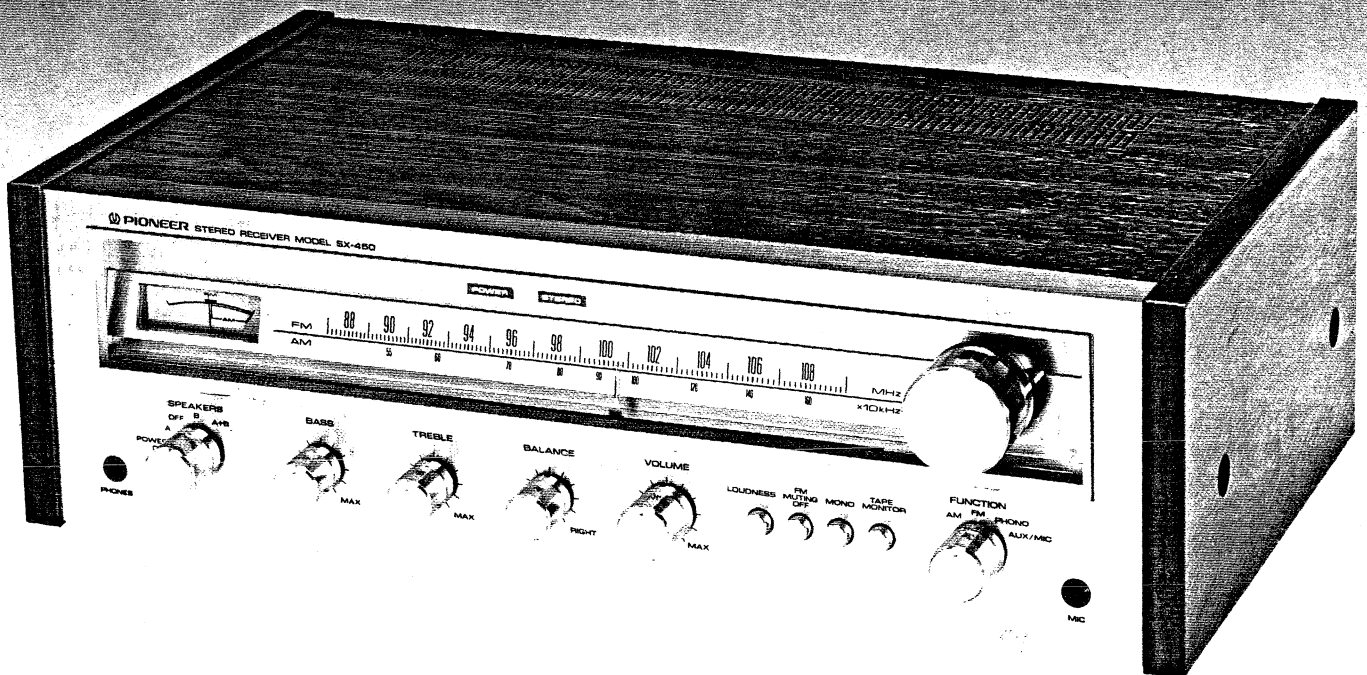

 PIONEER®

CONTENTS

1.	SPECIFICATIONS	4
2.	CONNECTION DIAGRAM	6
3.	FRONT PANEL FACILITIES	7
4.	BLOCK DIAGRAM	9
5.	CIRCUIT DESCRIPTIONS	11
6.	DISASSEMBLY	14
7.	LEVEL DIAGRAM	16
8.	PARTS LOCATIONS	
8.1	Front Panel View	17
8.2	Front View with Panel Removed	19
8.3	Rear Panel View	21
8.4	Top View with Cover Removed	23
9.	ADJUSTMENTS	
9.1	AM Section	25
9.2	FM Section	26
9.3	MPX Section	27
9.4	Power Amplifier Section (Idle current)	28
10.	DIAL CORD STRINGING	29
11.	NOMENCLATURE OF SCREWS, WASHERS AND NUTS	30
12.	ASSEMBLY EXPLODED VIEWS	
12.1	Exterior	31
12.2	Part 1 (Rear Panel)	33
12.3	RF Assembly (AWE-074)	35
12.4	AF Assembly (AWK-060)	36
13.	SCHEMATIC DIAGRAM, P.C. BOARD PATTERNS AND PARTS LIST	
13.1	Miscellaneous Parts List	37
13.2	Exterior View of Transistors and ICs	38
13.3	Schematic Diagram	39
13.4	RF Assembly (AWE-074)	41
13.5	AF Assembly (AWK-060)	49
14.	PACKING	55
15.	ADDITIONAL SERVICE MANUAL SX-450/HG, S	57

1. SPECIFICATIONS

Semiconductors

FET	1
ICs	3
Transistors	28
Diodes	15

Power Amplifier Section

Continuous Power Output from 20 Hertz to 20,000 Hertz (Both channels driven) 15 watts per channel (8 ohms).

Total Harmonic Distortion (20 Hertz to 20,000 Hertz, from AUX)

Continuous Rated Power Output No more than 0.5%
1 watt per channel power output,
8 ohms. No more than 0.1%

Intermodulation Distortion (50 Hertz : 7,000 Hertz = 4 : 1, from AUX)

Continuous Rated Power Output No more than 0.5%
1 watt per channel power output,
8 ohms No more than 0.1%

Damping Factor

(20Hz to 20,000Hz, 8 ohms) 25

Input Sensitivity/Impedance

PHONO 2.5mV/50k ohms
MIC 7.5mV/50k ohms
AUX 150mV/50k ohms
TAPE PLAY 150mV/50k ohms
TAPE PLAY (DIN connector) 150mV/50k ohms

PHONO Overload Level—T.H.D. 0.1%

PHONO 150mV (1kHz)

Output Level/Impedance

TAPE REC 150mV
TAPE REC (DIN connector) 30mV/80k ohms
SPEAKER A, B, A+B
HEADPHONE Low Impedance

Frequency Response

PHONO (RIAA equalization) 30Hz to 15,000Hz ± 0.5 dB
AUX, TAPE PLAY 20Hz to 60,000Hz ± 1 dB

Tone Control

BASS +10dB, -9dB (100Hz)
TREBLE +9dB, -10dB (10kHz)

Loudness Contour (Volume control set at -40dB

position) +6dB (100Hz), +3dB (10kHz)

Hum and Noise (IHF, short-circuited, A Network, rated power)

PHONO 70dB
AUX, TAPE PLAY 90dB

FM Section

Usable Sensitivity MONO 11.2dBf (2.0 μ V)
STEREO 20.0dBf (5.5 μ V)

50dB Quieting Sensitivity MONO 18.3dBf (4.5 μ V)
STEREO 39.2dBf (50 μ V)

Signal to Noise Ratio at 65dBf MONO 70dB
STEREO 65dB

Distortion at 65dBf 100Hz MONO 0.15%
STEREO 0.3%

1kHz MONO 0.15%
STEREO 0.3%

6kHz MONO 0.4%
STEREO 0.4%

Frequency Response 30Hz to 15,000Hz ± 0.5 dB

Capture Ratio 1.0dB

Alternate Channel Selectivity 60dB

Spurious Response Ratio 75dB

Image Response Ratio 65dB

IF Response Ratio 85dB

AM Suppression Ratio 50dB

Muting Threshold 14dBf (2.8 μ V)

Stereo Separation 40dB (1kHz), 30dB (30Hz ~ 15kHz)

Subcarrier Product Ratio 40dB

SCA Rejection Ratio 40dB

Antenna Input 300 ohms balanced
75 ohms unbalanced

AM Section

Sensitivity (IHF, Ferrite antenna) 300 μ V/m
 (IHF, Ext. antenna) 15 μ V
 Selectivity 35dB
 Signal-to-Noise Ratio 50dB
 Image Rejection 40dB
 IF Rejection 65dB
 Antenna Built-in Ferrite Loopstick Antenna

Miscellaneous

Power Requirements 120V 60Hz
 Power Consumption UL; 70W, 130W (max.)
 CSA; 120VA
 Dimensions 448(W)x141(H)x307(D) mm
 17-4/8(W)x5-9/16(H)x12-1/16(D) in
 Weight Without package 8.6kg (19 lb)
 With package 9.7kg (21 lb 6 oz)

Furnished Parts

FM T-type Antenna 1
 Operating Instructions 1

NOTE:
 Specifications and the design subject to possible modification without notice due to improvements.

MODEL SX-450 COMES IN FOUR VERSIONS DISTINGUISHED AS FOLLOWS:

Type	Voltage	Remarks
KU KC	120V only	CSA (Canada) and UL (U.S.A.) approved with de-emphasis selector switch (25 μ s/75 μ s).
HG	220V and 240V (Switchable)	SEMKO (Sweden), NEMKO (Norway), DEMKO (Denmark) and EI (Finland) approved.
S	110V, 120V, 220V and 240V (Switchable)	General export model with de-emphasis selector switch (25 μ s/50 μ s/75 μ s).

When repairing S or HG type, please see the manual on page 57.

2. CONNECTING DIAGRAM

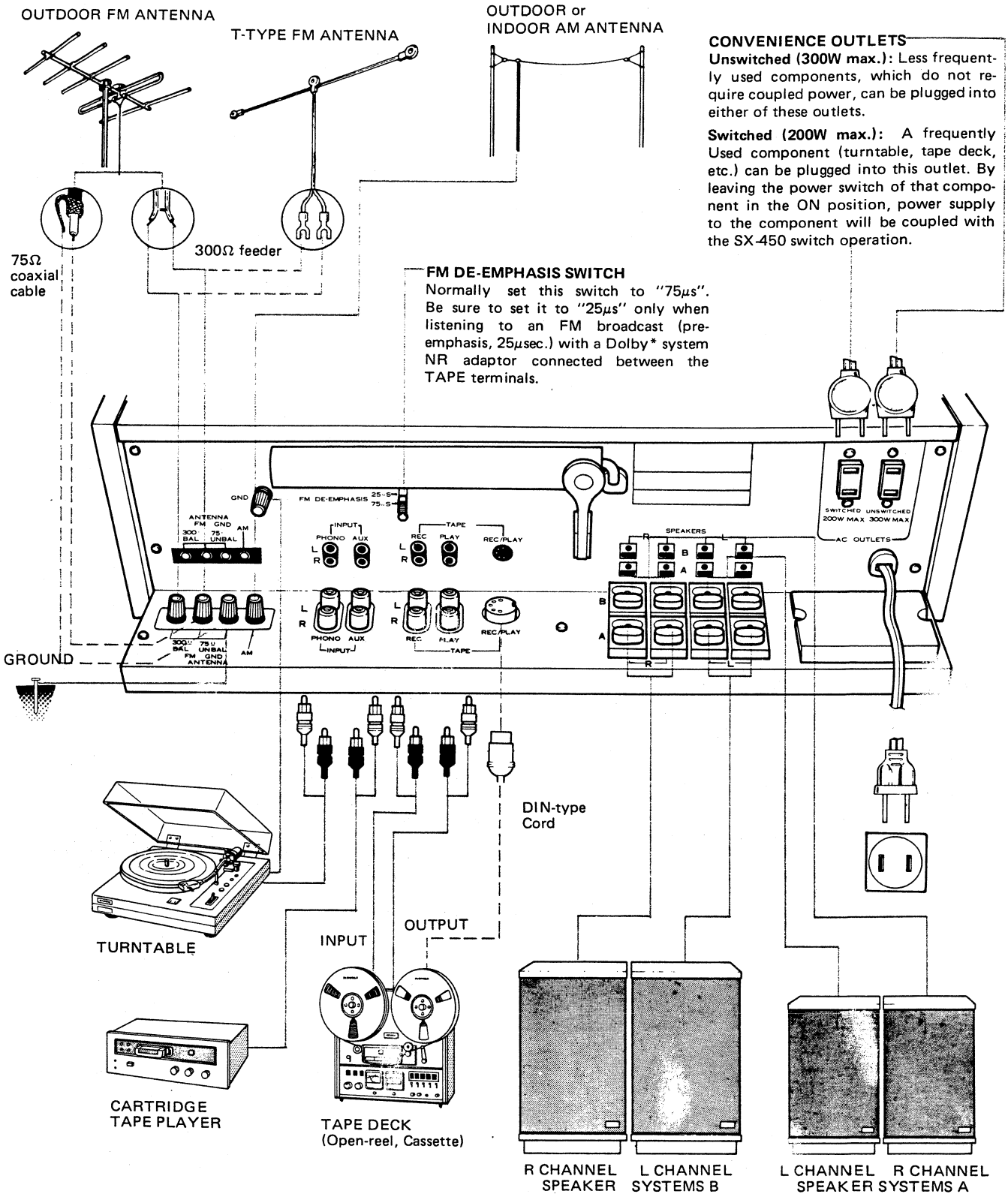

3. FRONT PANEL FACILITIES

SPEAKERS SWITCH(POWER)

A combined power ON/OFF switch and speaker system selector switch.

POWER OFF: Receiver off.

A: To select speakers connected to the A speaker terminals.

OFF: Speakers cut off (headphones can be used).

B: Operates speakers connected to the B speaker terminals.

A+B: To listen simultaneously to speaker systems connected to A and B speaker terminals.

NOTE:

For easier operation, plug power cord for turntable, etc. into the switched convenience outlet.

PHONES JACK

To listen through stereo headphones, plug them firmly into this jack.

WARNING:

Do not plug a microphone into the PHONES jack as you may damage the microphone.

AM/FM TUNING METER

When tuning in FM stations, position the needle in the center FM area for optimum reception. In the case of AM stations, tune for maximum meter deflection toward the right of the scale.

PILOT LAMP

Lights to indicate AC power ON.

FM STEREO INDICATOR

With the FUNCTION switch set to FM, the STEREO indicator lights while an FM stereo broadcast is being received.

TUNING KNOB

Select the desired station while observing the AM/FM meter for optimum tuning.

FUNCTION SWITCH

Switch for selecting desired program source.

AM: For AM broadcast reception.

FM: For FM stereo reception. Automatically receives monophonically during FM monophonic broadcasts. The STEREO indicator lights up when the broadcast is in stereo.

PHONO: To operate a turntable connected to PHONO jacks.

AUX/MIC: For listening to an audio component (cartridge tape player, TV sound tuner, etc.) connected to the AUX jacks. Also set to this position when using the microphone.

Note, when the microphone is plugged in, the component connected to the AUX jacks cannot be used.

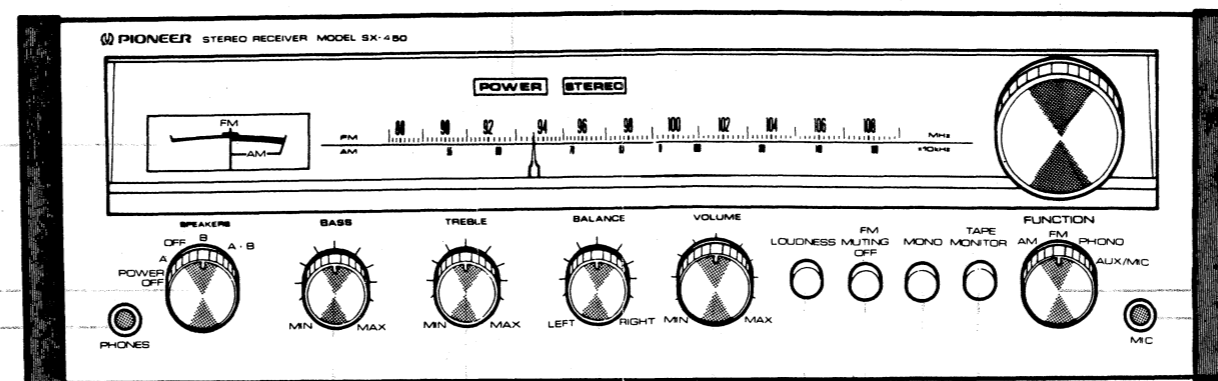

BASS & TREBLE CONTROLS

Controls for adjusting the tone. Adjust low frequencies with the BASS control and high frequencies with the TREBLE control.

Turn controls toward the right (MAX) to enhance, and toward the left (MIN) to reduce, their respective frequency ranges.

BALANCE CONTROL

Control for adjusting volume balance between left and right speakers or headphones. Clockwise rotation from center increases right channel volume, while counter-clockwise rotation increases left channel volume.

FM MUTING OFF BUTTON

Leave this button undepressed (in the ON position) to suppress unpleasant interstation noise while tuning between FM stations. Low-strength signals may also be suppressed by this function, so to pick up a weak station depress this button to the OFF position.

LOUDNESS BUTTON

Depress this switch when listening at low volume. The frequency response of the human ear varies according to the listening level, and the depressed position compensates for hearing characteristics by emphasizing the bass and treble.

VOLUME CONTROL

Clockwise rotation increases volume from speakers or headphones.

MIC JACK

A high impedance (approx. 50k-ohms) dynamic type microphone with a standard plug can be connected to this jack.

TAPE MONITOR BUTTON

Depress this switch when using a tape deck for tape playback, or when monitoring a tape during recording.

NOTE:

Except for tape playback, keep this switch in the underpressed position.

MODE SWITCH (MONO)

For stereo playback leave this switch undepressed. When depressed for MONO playback, left and right channel stereo signals will be mixed to produce monophonic sound from both speaker systems.

NOTE:

Recording stereophonically with the MODE switch in the MONO position may cause channel separation to deteriorate.

4. BLOCK DIAGRAM

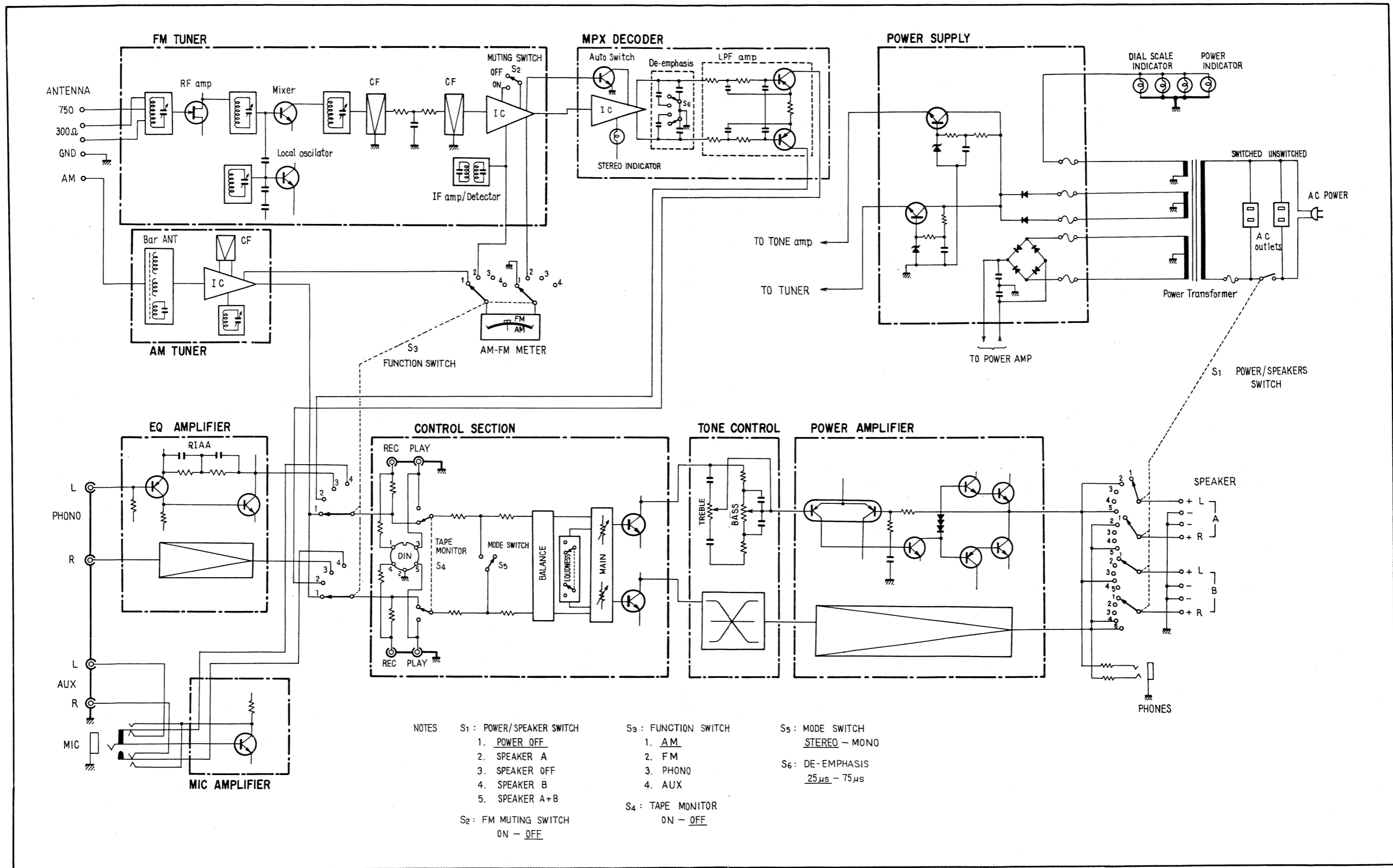

5. CIRCUIT DESCRIPTIONS

AM TUNER

Composed of a single IC (HA 1138) and single element ceramic filter. A 2-gang variable capacitor is employed with one stage providing tuning between the antenna and RF amplifier and the other stage tuning the local oscillator (Fig. 1).

FM FRONT END

A frequency linear 3-gang variable capacitor is used with a single stage FET RF amplifier. The FET possesses high input impedance compared with a transistor, and allows simple coupling with the input tuning circuit, plus a significant ad-

vantage in terms of noise.

The local oscillator is a variation of a Clapp circuit and its excellent temperature compensation provides stable frequency even without AFC. Local oscillator voltage is passed through a low value capacitor to the mixer transistor base.

IF AMPLIFIER AND DETECTOR

Composed of two dual element ceramic filters and one IC (HA1137). The HA1137 is a high density IC and contains a limiter amplifier, FM detector (quadrature detector), muting, and meter drive circuits (Fig. 2).

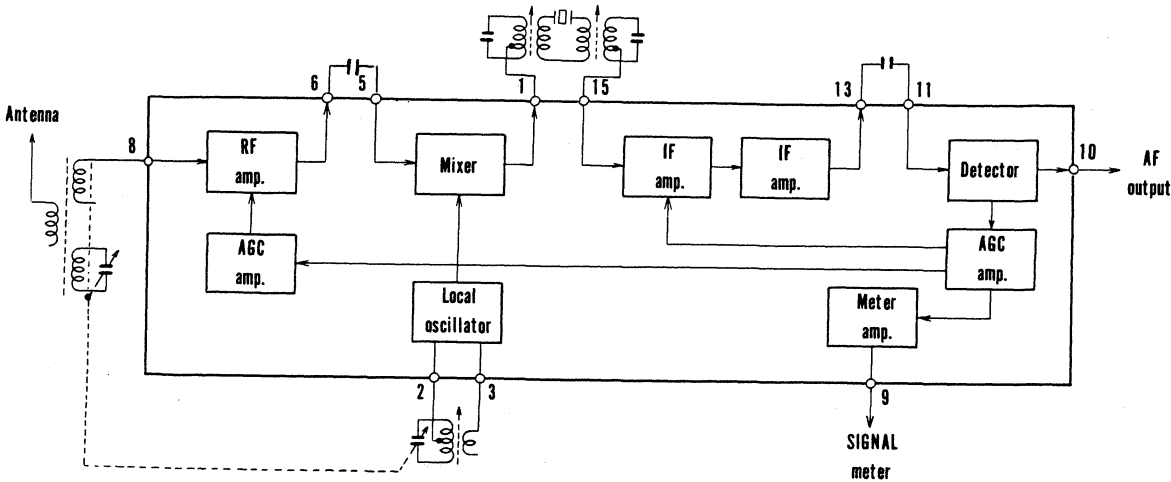

Fig. 1 Block diagram for HA1138

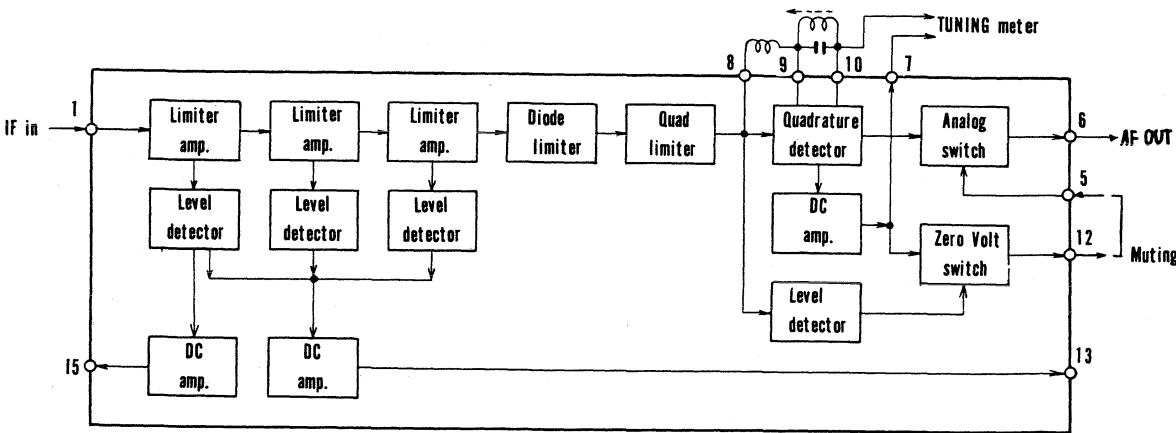

Fig. 2 Block diagram for HA1137

MULTIPLEX DECODER

Demodulation is performed by switching detection. A single IC (HA1156) composed the circuit, which is divided into 3 sections.

The block diagram is shown in Fig. 3.

1. Switching signal generator

A PLL (phase locked loop) system is employed. 76kHz is generated by a VCO (voltage controlled oscillator) and converted into 19kHz by a frequency divider.

This signal and the pilot (19kHz) of the received signal are applied to the phase comparator, which converts the phase differences of the two signals into a voltage. This voltage is then fed back to the VCO. The oscillator signal phase becomes locked to the pilot signal by this loop (PLL) and a 38kHz signal synchronized to the pilot signal is obtained and employed as the switching signal.

2. Automatic stereo detector

With the PLL locked to the pilot signal, the pilot signal and a 19kHz signal of the same phase are produced. A voltage is then obtained at the phase comparator that is proportional to the pilot signal amplitude. As it increases, the lamp lights and switch becomes on.

The switching signal is applied to the demodulator.

3. Demodulator

A differential amplifier is employed in a switching detection system. Fig. 4 shows the basic circuit. The composite signal is applied to Q3, while the switching signal (38kHz) goes to Q1 and Q2, causing the composite signal to become alternately on and off. The 38kHz carrier is cancelled by C1, R1 and C2, R2.

Square wave of 180° angle of current flow is employed as the switching signal in order to increase demodulation efficiency. However, since only about 13dB separation can be obtained from this basic design, the actual circuit becomes as shown in Fig. 5. It combines two Fig. 4 circuits, with Q4 - Q6 cancelling crosstalk.

The composite signal appearing at Q3 emitter is applied to Q6 emitter and a low level signal is produced at Q6 collector in opposite phase to Q3. This signal is employed for composition at the collector, cancelling crosstalk. By adjusting R_E in this circuit, separation can be improved to about 40dB.

MICROPHONE CIRCUIT

A single transistor amplifier (monophonic) is provided in addition to the phono equalizer amplifier. A selector switch cuts the AUX jack input when a plug is inserted into the MIC jack. The

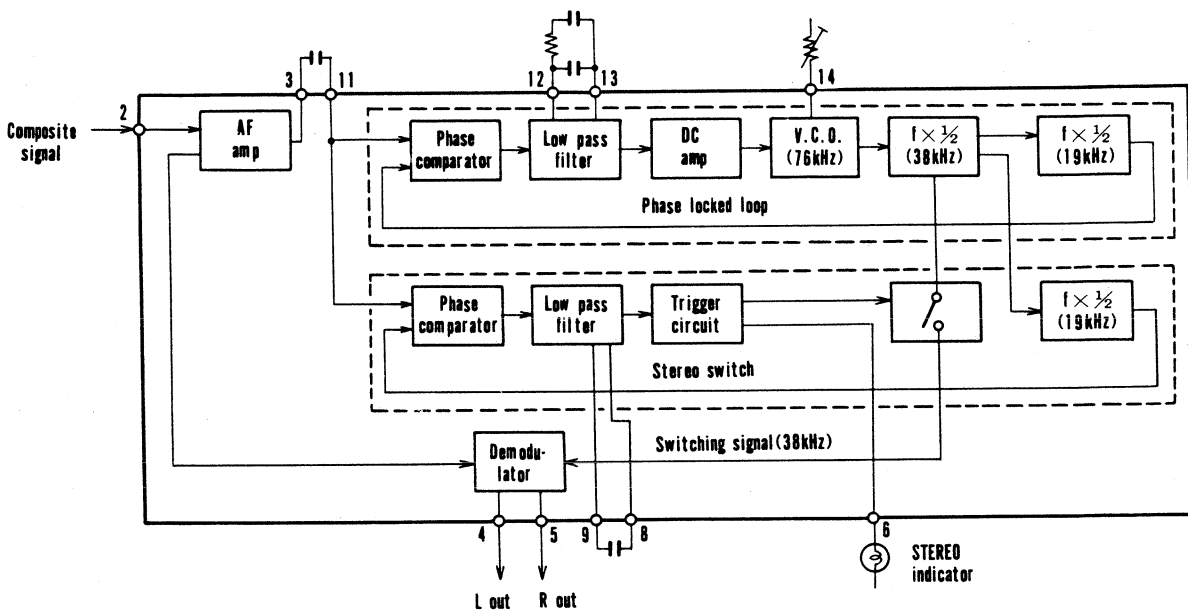

Fig. 3 Block diagram for HA1156

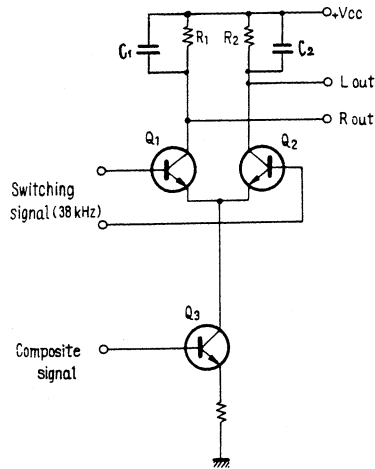

Fig. 4

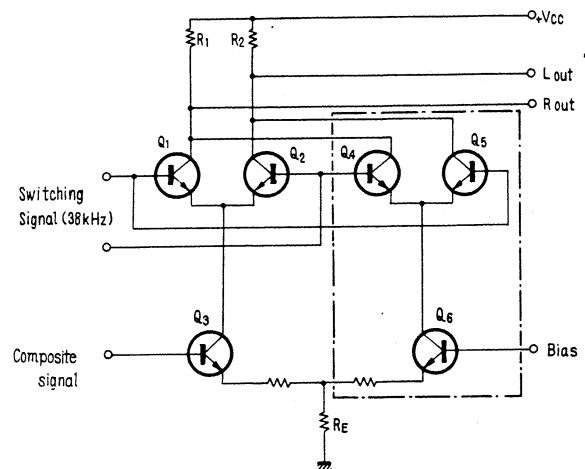

Fig. 5

amplified microphone signal is then supplied to both the left and right channels. The FUNCTION switch is set to the AUX position when using a microphone.

TONE CONTROL

A CR network tone control system is used. The attenuator circuits used each consist of a capacitor and a resistor. They increase and decrease the relative levels of high and low frequency sound. Because the attenuator gives relative control over the frequency response, there is constant loss. To compensate for this, an amplifier is employed prior to this stage.

EQUALIZER AMPLIFIER

This amplifier amplifies the low level signals from the cartridge inputs. Equalization is performed in accordance with the RIAA curve. This is a two-stage, direct-coupled, collector-to-emitter feedback type.

POWER AMPLIFIER

Power amplifier employs all stage direct-coupled quasi complementary circuit (Fig. 6).

It is an OCL circuit with balanced positive and negative power supply and center output potential kept at 0V.

The first stage (Q201 and Q203) composes a differential amplifier designed for both signal amplification and stabilization of the center point potential.

The predriver (Q205) is a class A amplifier. The next stage (Q207 and Q209) composes a complementary circuit and employs a Darlington connection Q207 — Q211 and inverted Darlington connection Q209 — Q213 with the final stage.

POWER SUPPLY

Voltage of Q301 and Q302 bases are controlled by zener diodes (D303, D304).

Tuner power is taken from Q302 emitter. Since this is at the power transformer secondary, AC line variation do not directly reach the tuner.

Also supplied balanced positive and negative power from bridge rectifier and two 4,700μF capacitors to the power stage (Fig. 7)

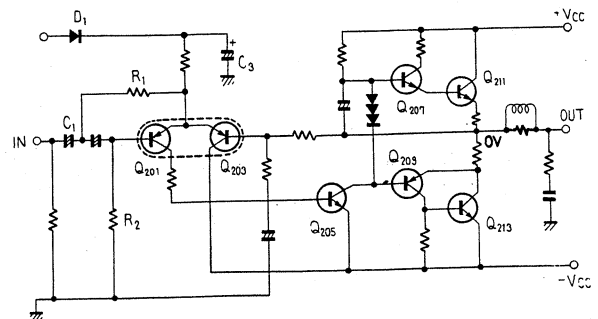

Fig. 6

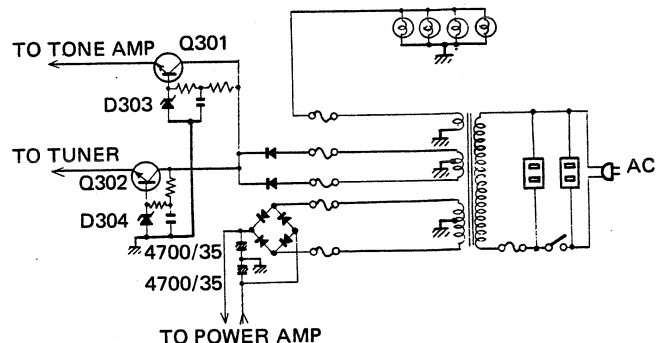

Fig. 7

6. DISASSEMBLY

SIDE PANEL

Remove the 4 screws on the each side of the side panel as shown in Fig. 8.

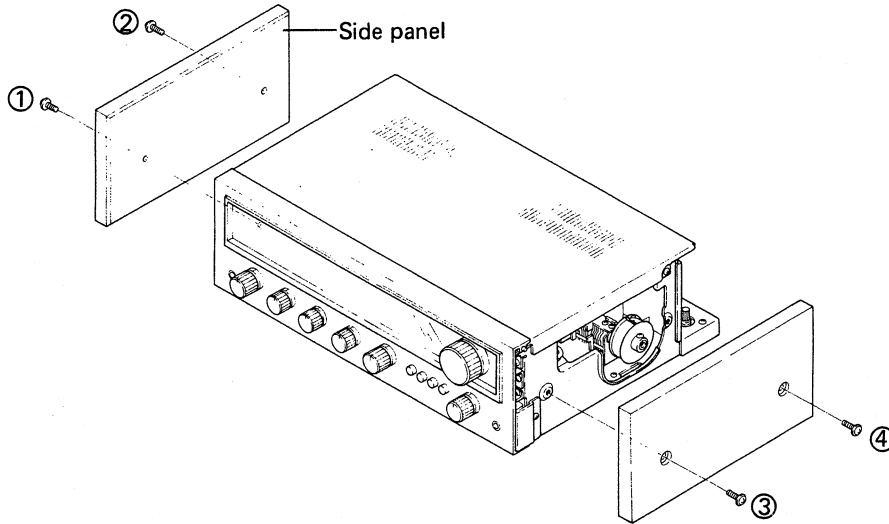

Fig. 8

TOP PLATE

Remove the 2 screws to detach the top plate as shown in Fig. 9.

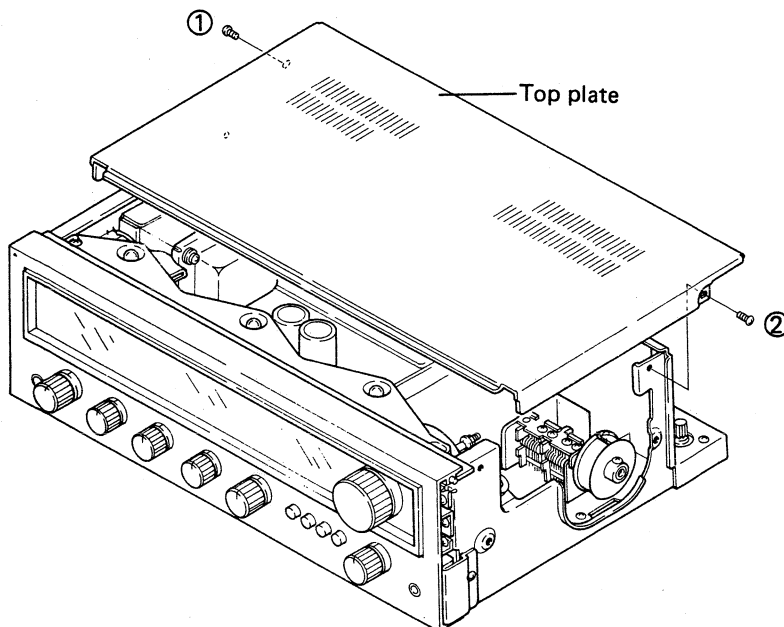

Fig. 9

BOTTOM PLATE

Remove the 8 screws to detach the bottom plate as shown in Fig. 10.

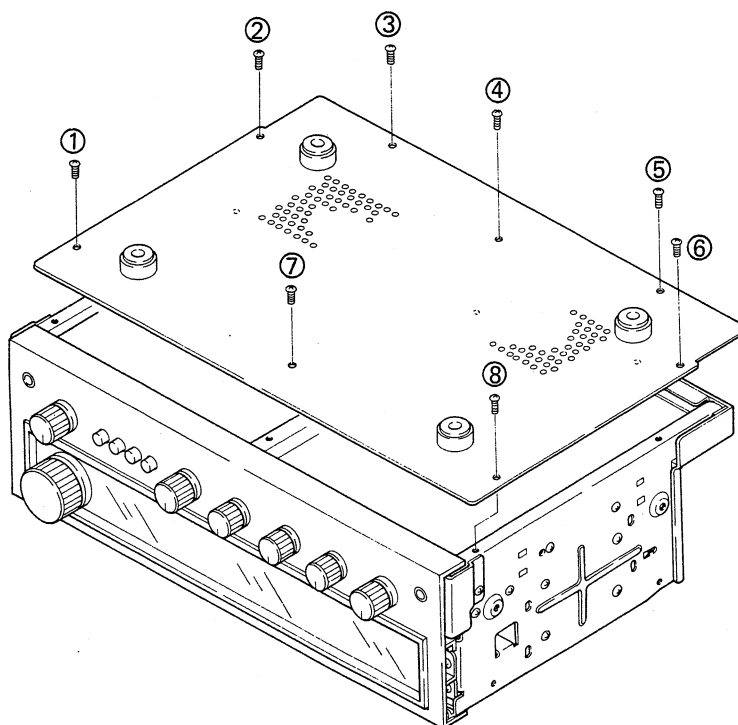

Fig. 10

FRONT PANEL

1. Pull off all knobs (except push switch knob), then remove shaft nuts A, B of FUNCTION and SPEAKER switches.
2. Remove the 2 screws (Left and Right) from the edge of the front panel.
3. Remove the front panel as shown in Fig. 11.

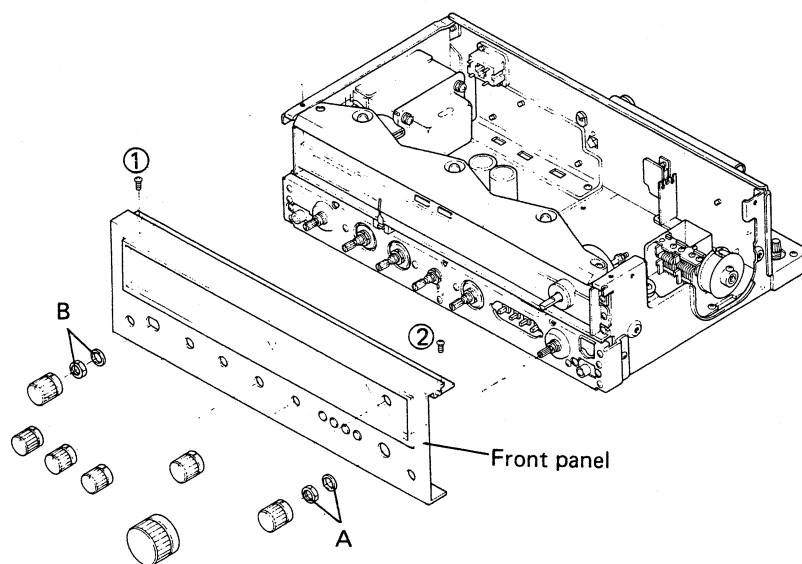
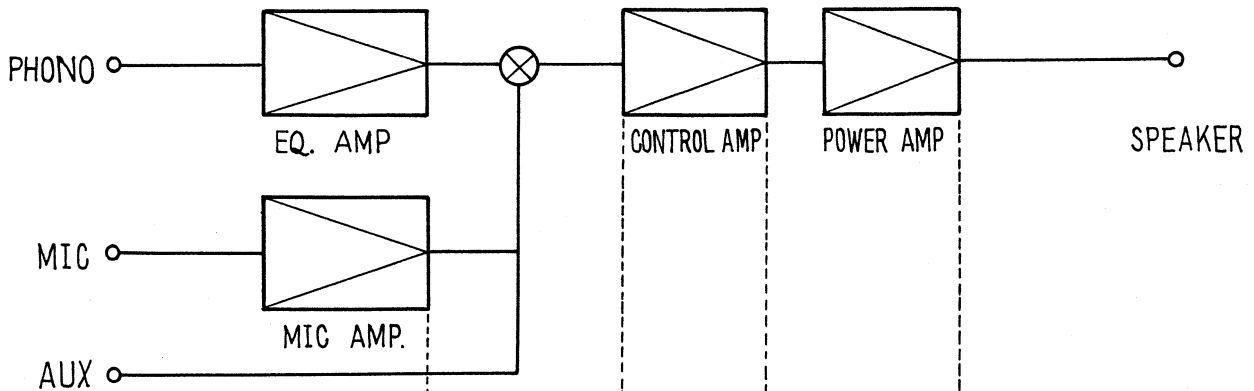
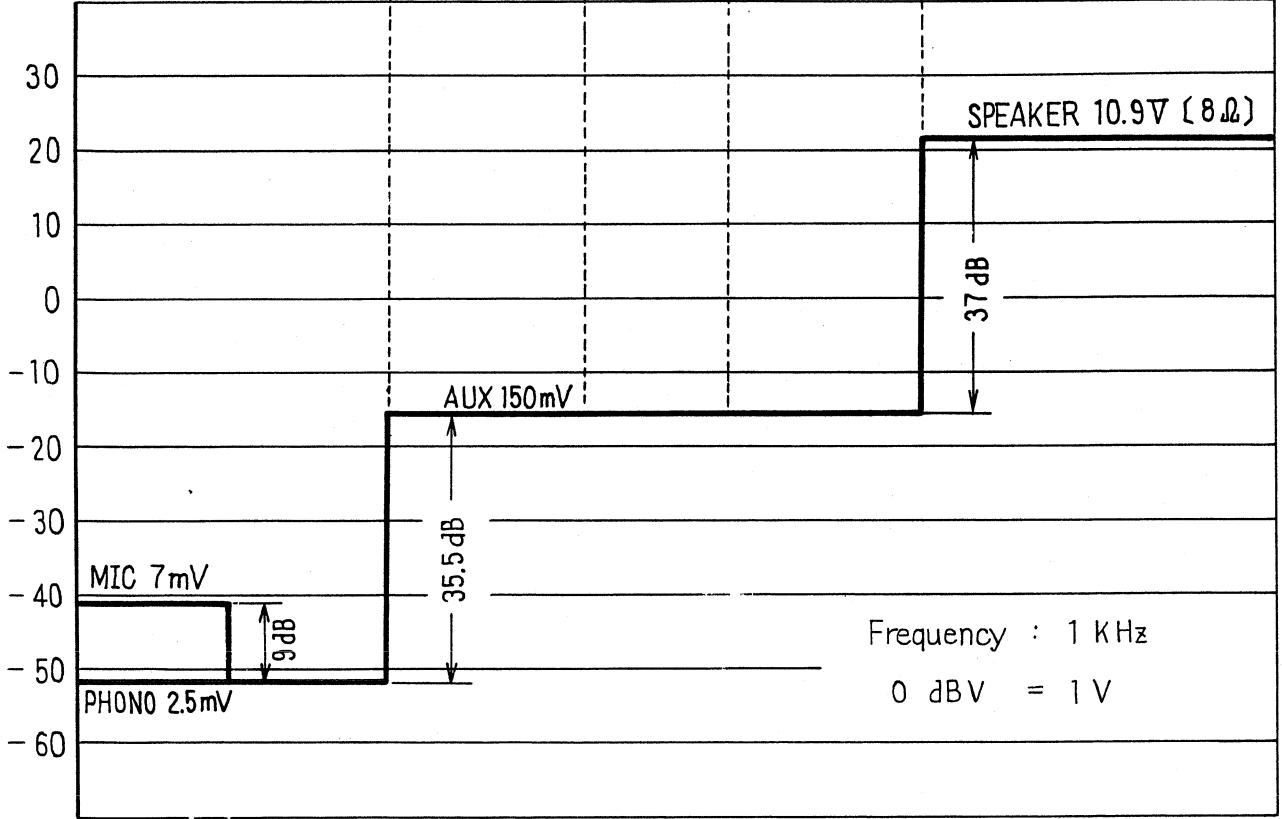

Fig. 11

7. LEVEL DIAGRAM



LEVEL [dBV]



8. PARTS LOCATIONS

8.1 FRONT PANEL VIEW

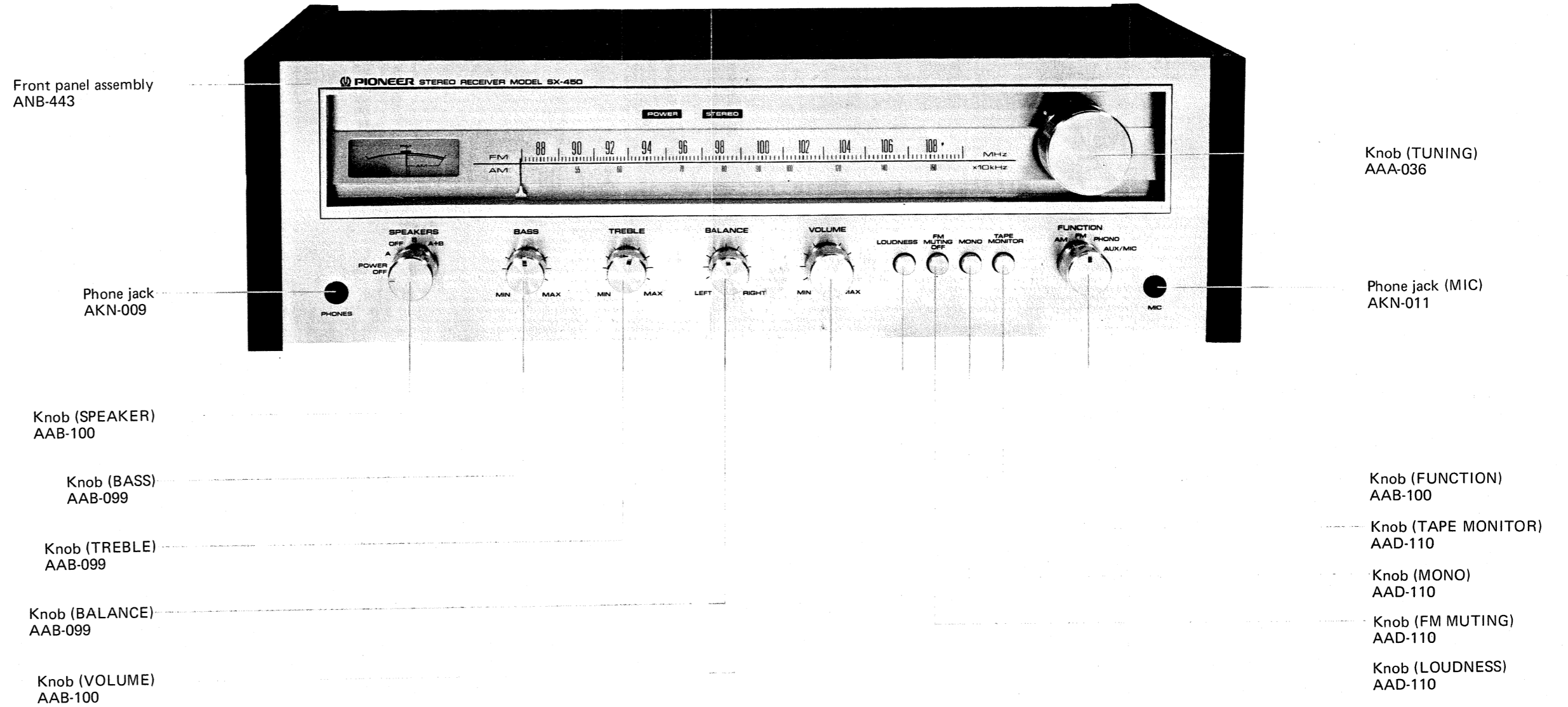

8.2 FRONT VIEW WITH PANEL REMOVED

Dial pointer assembly
AAF-046

Meter (AM/FM)
AAW-053

Dial scale board
AAG-113

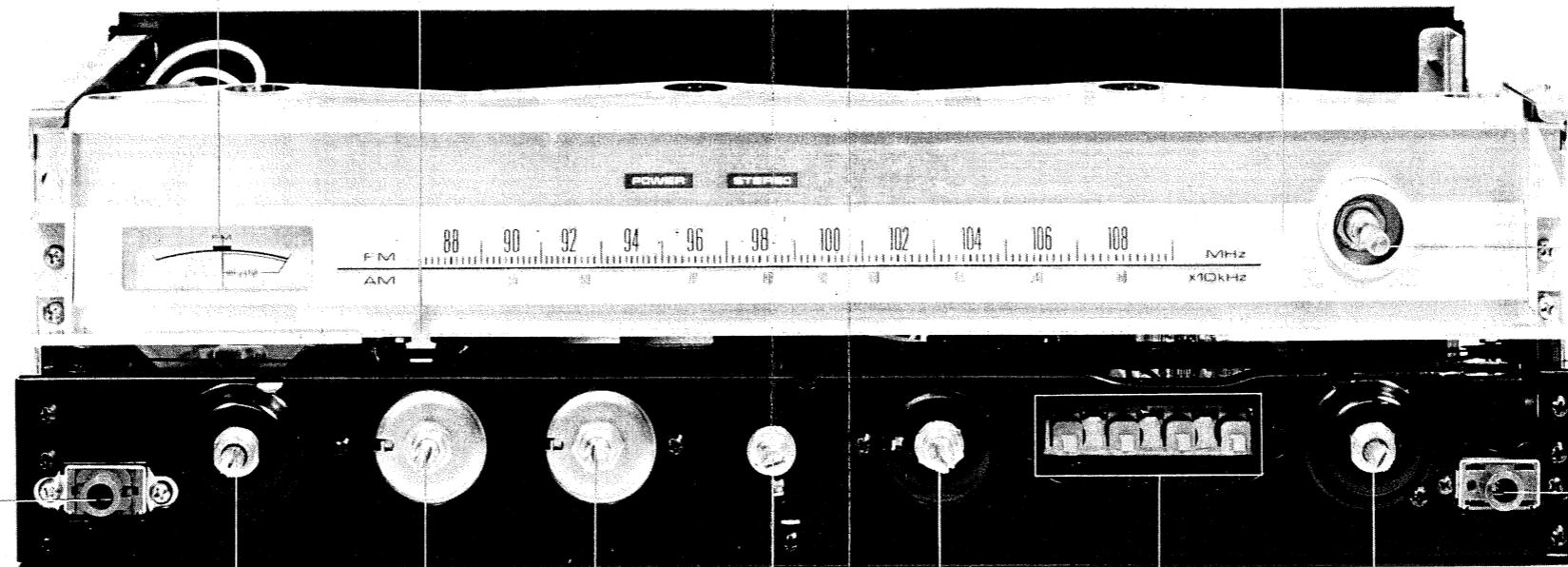

Tuning shaft assembly
AXA-117

Phone jack
AKN-009

Phone jack (MIC)
AKN-011

Rotary switch (SPEAKER)
ASA-042

Rotary switch (FUNCTION)
ASD-048

Variable resistor (BASS)
ACV-180

Push switch assembly
ASG-115

Variable resistor (TREBLE)
ACV-180

Variable resistor (VOLUME)
ACV-161

Variable resistor (BALANCE)
ACV-020

8.3 REAR PANEL VIEW

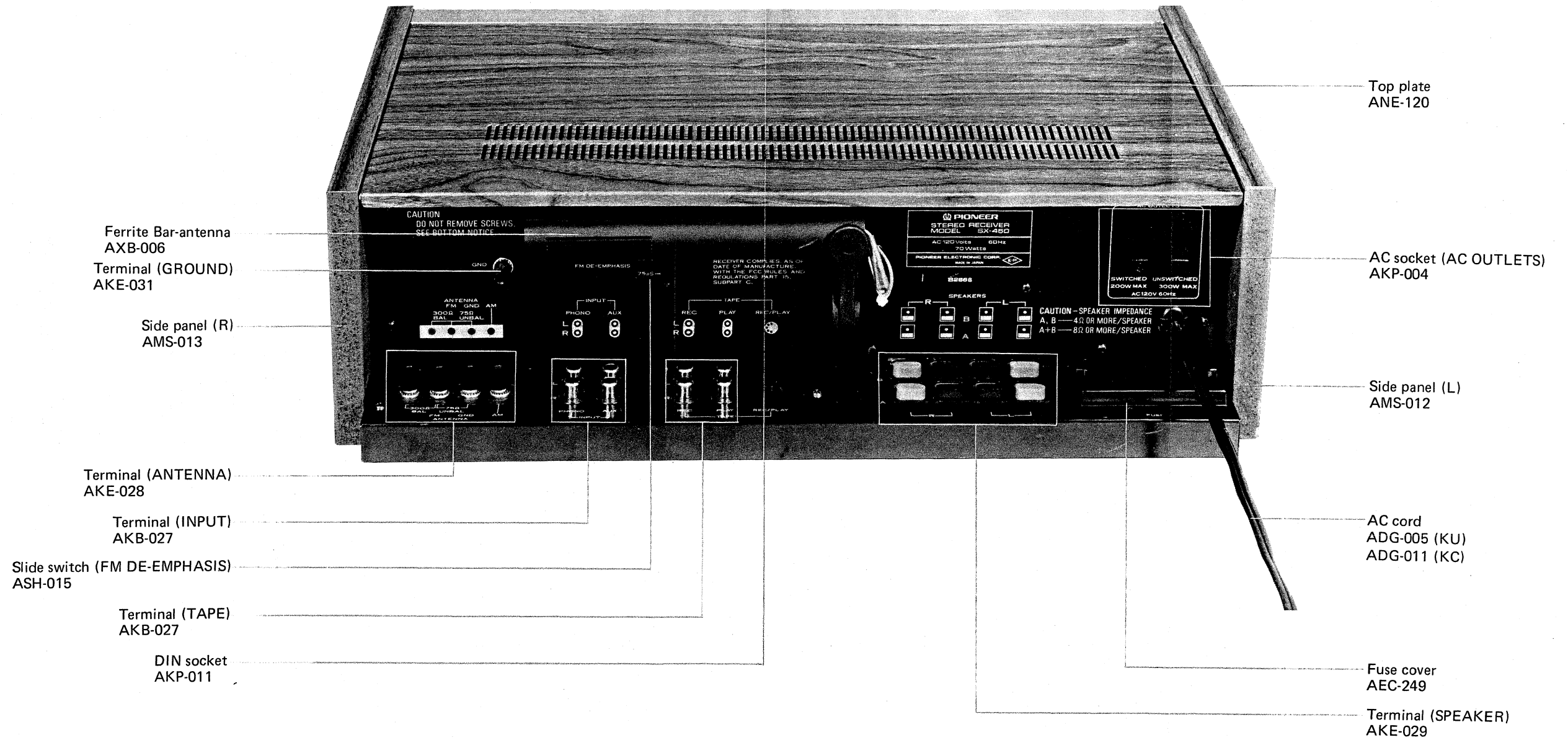

8.4 TOP VIEW WITH COVER REMOVED

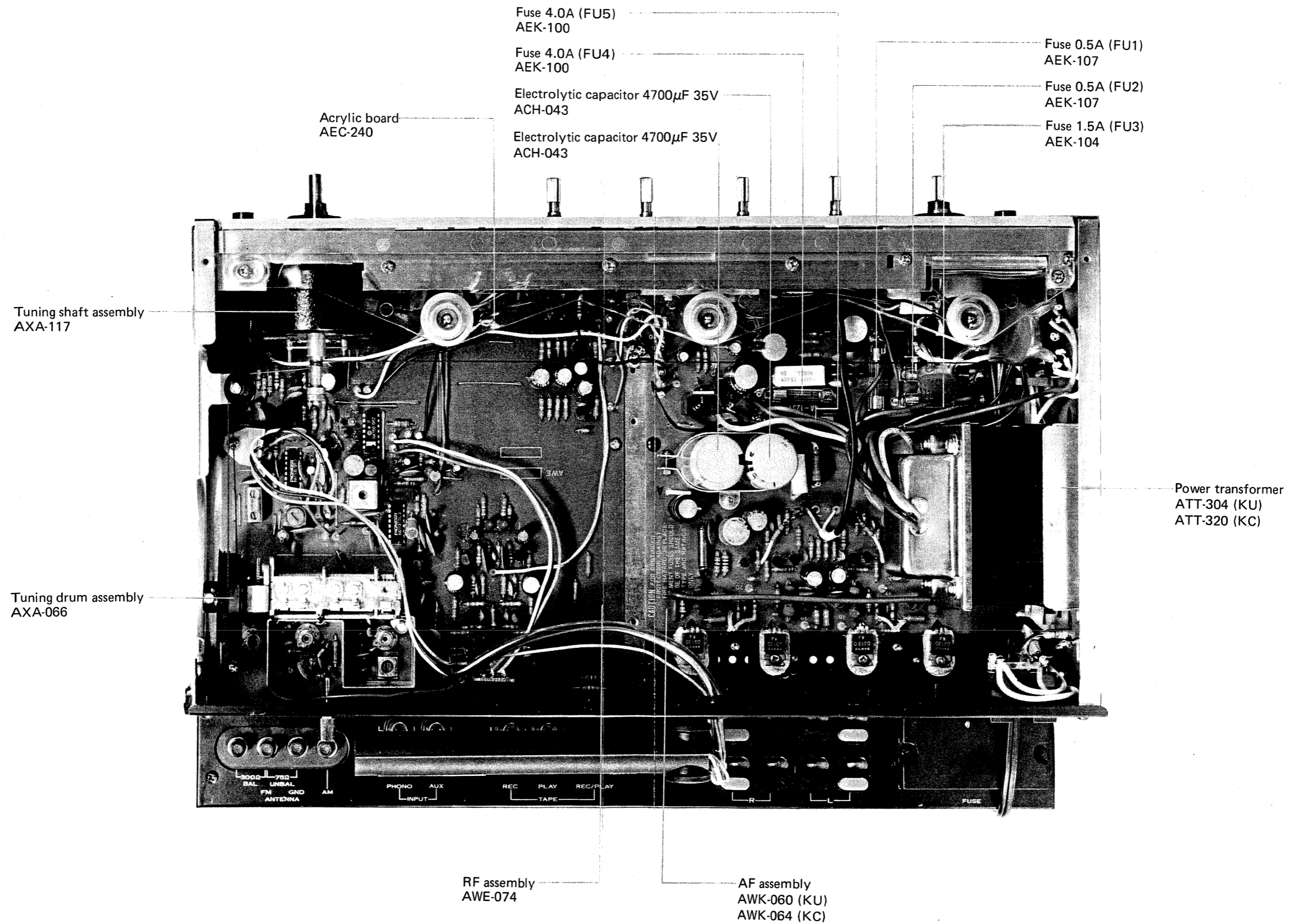

9. ADJUSTMENT

9.1 AM SECTION

1. Through a 1k ohm resistor, connect an AM signal generator to the AM antenna terminal. Set for 400Hz at 100dB and 30% modulation.
2. Connect AC voltmeter to TAPE REC jack (L or R).
3. Set FUNCTION switch to AM position.
4. Set AM signal generator and SX-450 dial indication to point A (600kHz).
5. Adjust T6 for maximum indication on AC voltmeter.
6. Set AM signal generator and SX-450 dial indication to point C (1,400kHz).
7. Adjust TC4 for maximum indication on AC voltmeter.
8. Again set AM signal generator and SX-450 dial indication to point A.
9. Adjust bar antenna core for maximum indication on AC voltmeter.
10. Return AM signal generator and SX-450 dial indication to point C.
11. Adjust TC5 for maximum indication on AC voltmeter.
12. Repeat steps 4-11 to eliminate variations in AC voltmeter indications at point A and C.

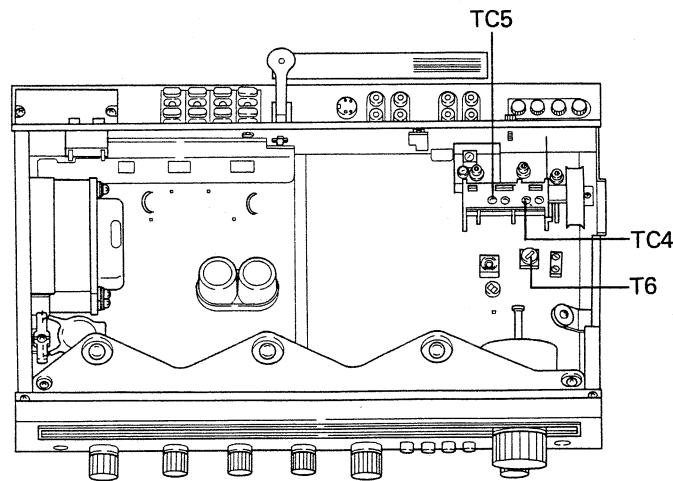
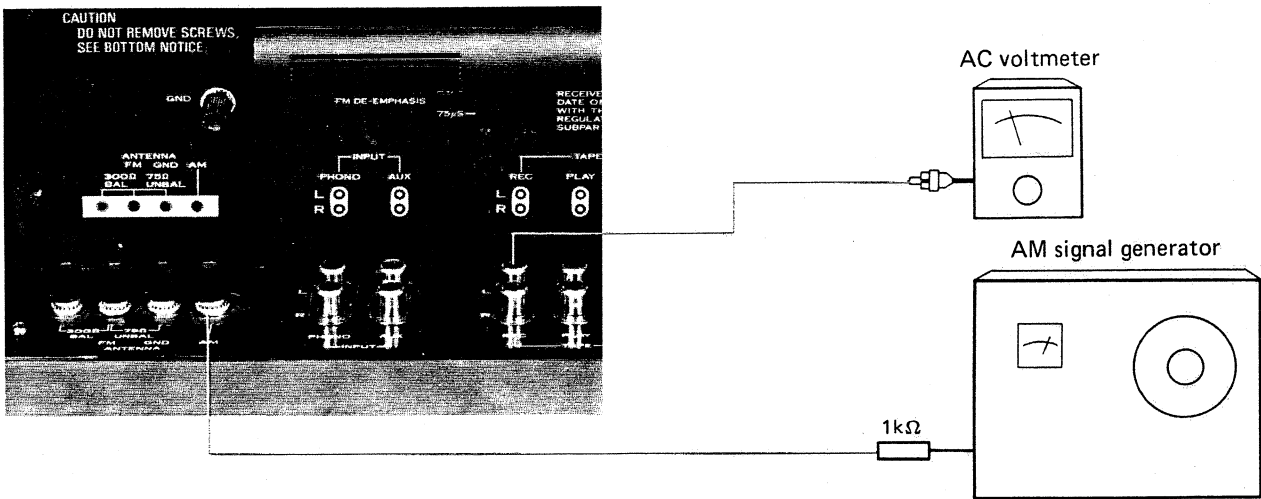

9.2 FM SECTION

1. Through 300 ohm dummy antenna, connect FM signal generator to the 300 ohm FM antenna terminals and set for 400Hz at 100dB and 100% modulation.
2. Connect AC voltmeter and distortion meter to TAPE REC jack (L or R).
3. Set FUNCTION switch to FM and MUTING switch to OFF.
4. Set FM signal generator and SX-450 dial indication to point A (90MHz).
5. Adjust T3 for maximum indication on AC voltmeter.
6. Adjust T5 lower core for center of scale indication on AM/FM meter.
7. Set FM signal generator for 9dB output and adjust T1 and T2 for maximum indication on AC voltmeter.
8. Set FM signal generator and SX-450 dial indication to point C (106MHz).
9. Adjust TC3, then TC1 and TC2 for maximum indication on AC voltmeter.
10. Again set FM signal generator and SX-450 dial indication to point A.
11. Adjust T3, then T1 and T2 for maximum indication on AC voltmeter.
12. Repeat steps 8-11 to eliminate variations in sensitivity at points A and C.
13. Adjust T4 for maximum sensitivity.
14. Detune to noise only and adjust T5 lower core for center of scale indication on FM meter.
15. Set SX-450 dial indication to point B (98MHz) and adjust FM signal generator for center of scale indication on AM/FM meter.
16. Set FM signal generator output to 60dB and adjust T5 upper core for minimum distortion.
17. Repeat steps 14-16 eliminate variation in minimum distortion position.

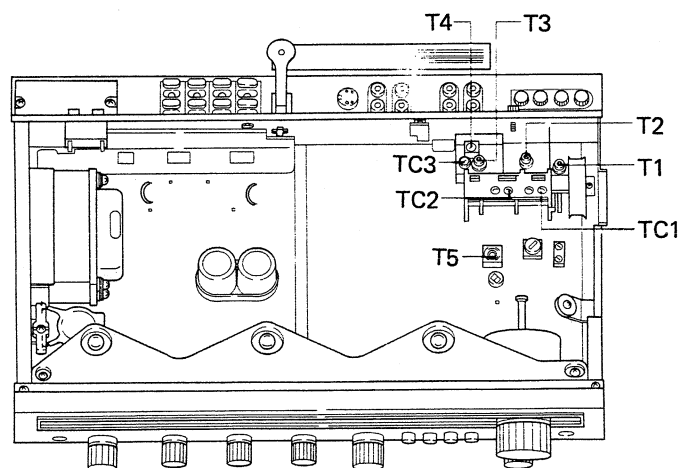
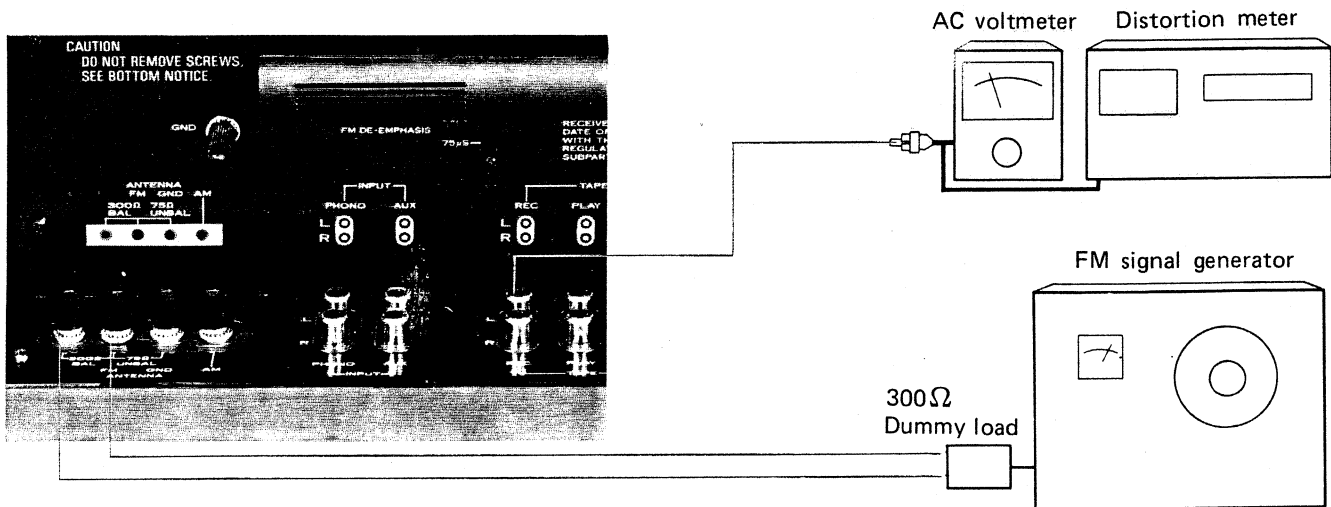

9.3 MPX SECTION

1. Through 300 ohm dummy antenna, connect FM signal generator to 300 ohm FM antenna terminals.
2. Connect multiplex signal generator to external modulation terminals of FM signal generator.
3. Connect oscilloscope horizontal input to MPX signal pilot output and vertical input via probe to TP (No. 13) of circuit board.
4. Set SX-450 dial indication to 98MHz and adjust FM signal generator for center of scale indication on AM/FM meter.
5. With FM signal generator unmodulated, adjust VR1 so that lissajous pattern on oscilloscope becomes stationary as shown in Fig. 12.
6. With MPX signal generator modulation 1kHz, L + R 67.5kHz deviation and pilot 7.5kHz deviation, adjust T4 for minimum distortion.

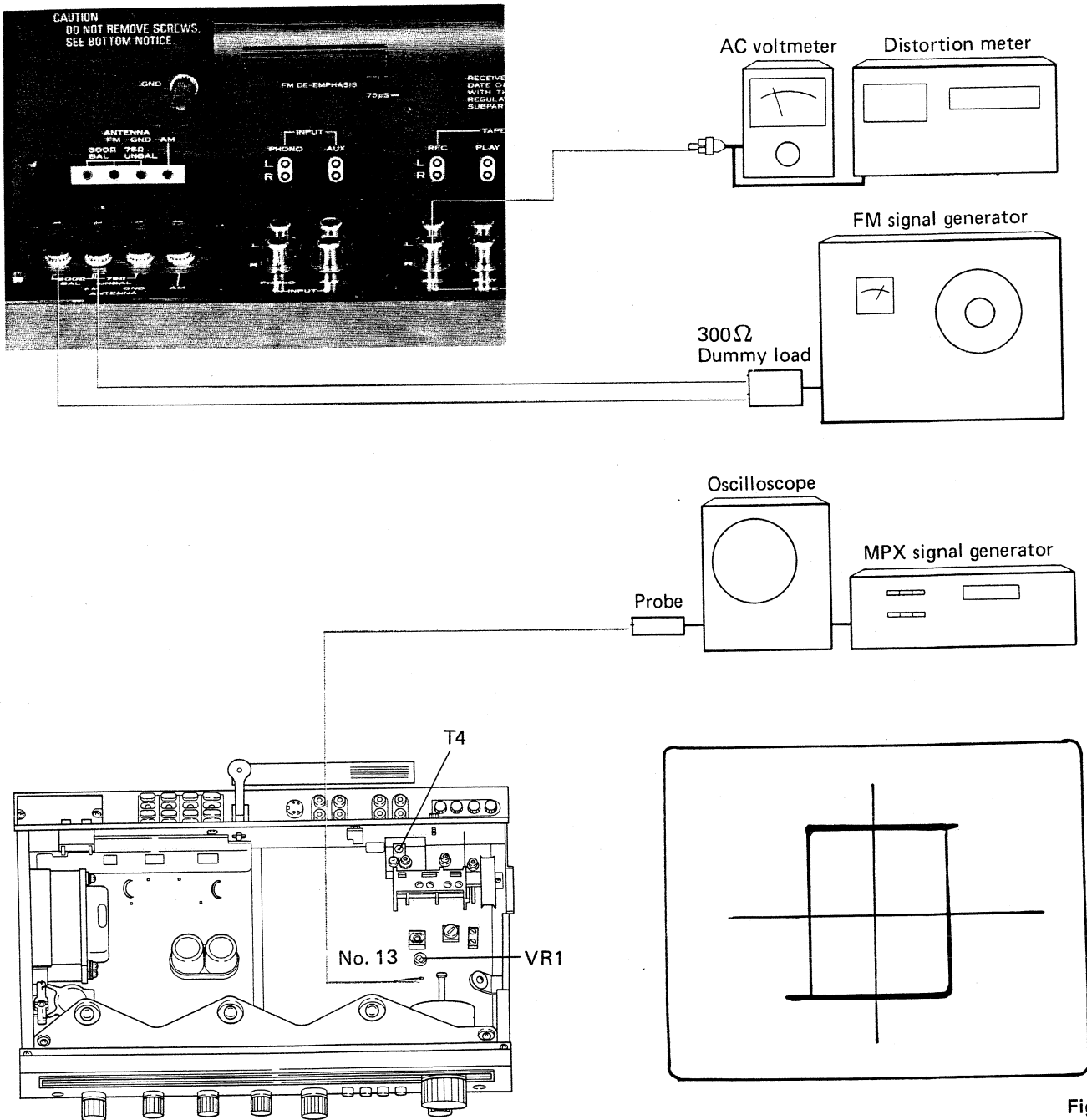
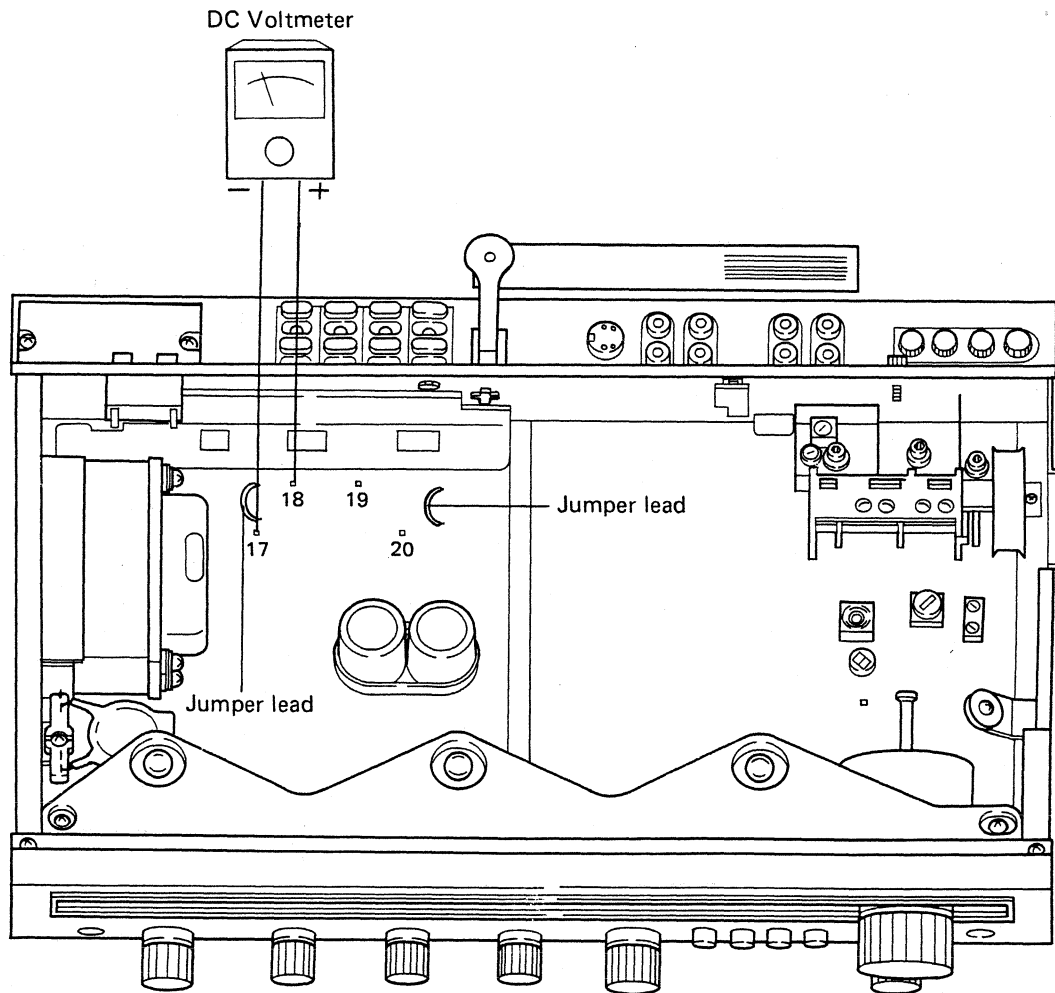

Fig. 12

9.4 POWER AMPLIFIER SECTION (IDLE CURRENT)

1. Set BASS and TREBLE controls to center position.
2. Nothing should be connected to the INPUT jacks of SX-450 and an 8 ohm dummy load should be connected across the SPEAKER terminal.
3. A DC voltmeter should be connect across between terminal number 19 (+), 20 (-) for Left channel and 18 (+), 17 (-) for Right channel.
4. Cut the jumper lead, if the voltage less than 15mV.



10. DIAL CORD STRINGING

Remove the Front panel (See page 14, 15).

1. Turn tuning drum fully clockwise (as viewed from X direction in Fig. 13).
2. Tie one end of cord to stud on inner section of tuning drum (more easily performed by loosening setscrew and temporarily removing tuning drum from shaft).
3. Pass cord through pulley opening, make a half turn around the pulley, then route in the sequence: pulley A-Dial needle-pulley B-C.
4. Wind cord clockwise (as viewed from rear panel) 3 turns around dial shaft, then route to pulley D.
5. Wind 3 turns around dial pulley and tie to spring so that the cord is under tension.
6. Turn TUNING knob and confirm normal cord-motion, then trim off excess cord.
7. With tuning capacitor blades fully closed, move dial needle to starting point (left edge of scale).
8. Apply laquor to tied ends of cord.

DIAL NEEDLE INSTALLATION CAUTION

Metal portion of dial pointer is plated. If this section is touched directly by hand or fingerprints and other impurities, it is difficult to remove dirt from aventurine finish. As this is not desirable in terms of both appearance and anti-corrosion, take extreme care not to touch the metal section when handling the dial needle.

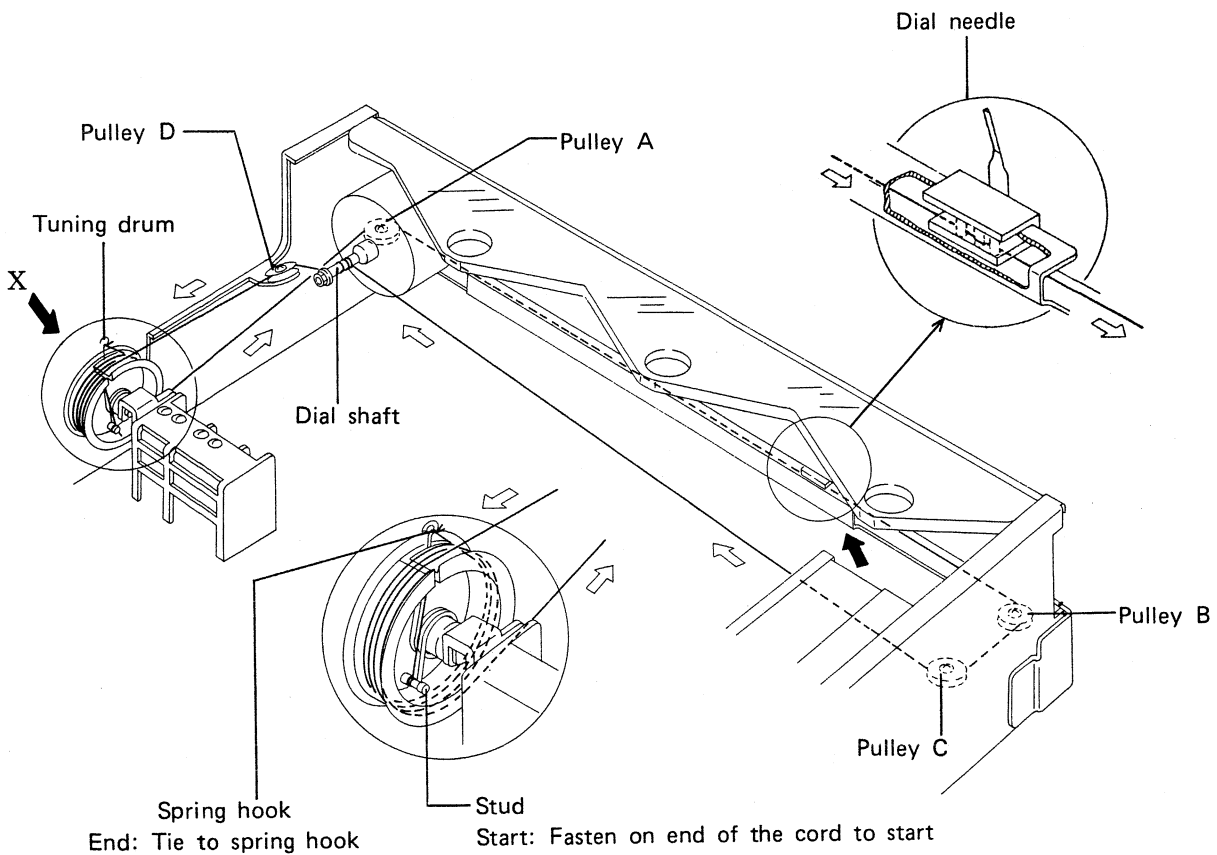













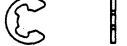













Fig. 13

11. NOMENCLATURE OF SCREWS, WASHERS AND NUTS

The following symbols stand for screws, washers and nuts as shown in exploded view.

Symbol	Description	Shape
RT	Brazier head tapping screw	
PT	Pan head tapping screw	
BT	Binding head tapping screw	
CT	Countersunk head tapping screw	
TT	Truss head tapping screw	
OCT	Oval countersunk head tapping screw	
PM	Pan head machine screw	
CM	Countersunk head machine screw	
OCM	Oval countersunk head machine screw	
TM	Truss head machine screw	
BM	Binding head machine screw	
PSA	Pan head screw with spring lock washer	
PSB	Pan head screw with spring lock washer and flat washer	
PSF	Pan head screw with flat washer	

Symbol	Description	Shape
EW	E type washer	
FW	Flat washer	
SW	Spring lock washer	
N	Nut	
WN	Washer faced nut	
ITW	Internal toothed lock washer	
OTW	Outernal toothed lock washer	
SC	Slotted set screw (Cone point)	
SF	Slotted set screw (Flat point)	
HS	Hexagon socket headless set screw	
OCW	Oval countersunk head wood screw	
CW	Countersunk head wood screw	
RW	Round head wood screw	

EXAMPLE

PM • 3x8

length in mm (l)
 diameter in mm (d)
 Symbol

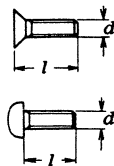

FW • 9φ x 1^t

thickness in mm (t)
 diameter in mm (d)
 Symbol

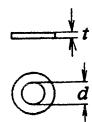

12. ASSEMBLY EXPLODED VIEW

12.1 EXTERIOR

NOTE:
Parts indicated in green type cannot be supplied.

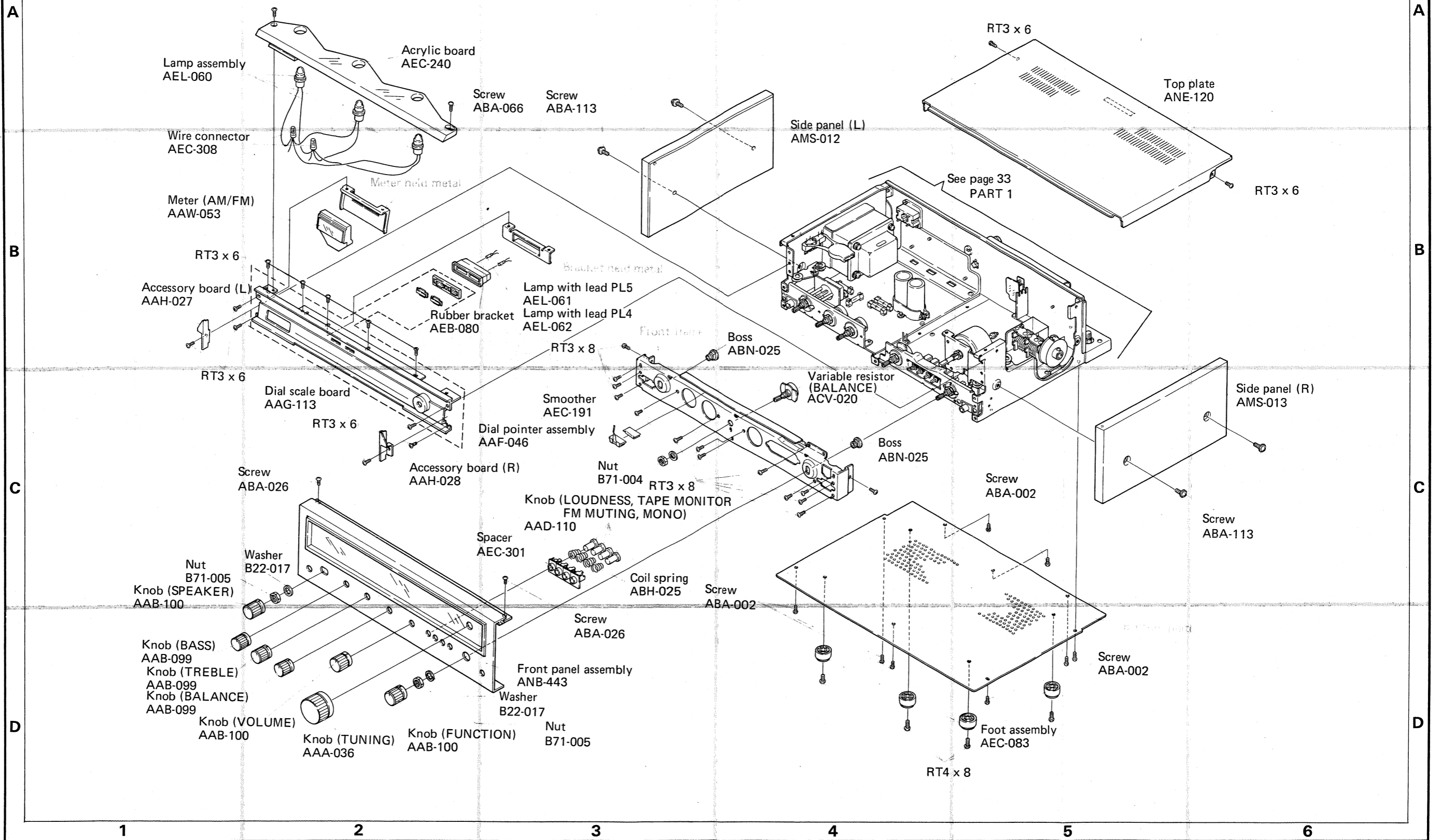

12.2 PART 1 (REAR PANEL)

NOTE:
Parts indicated in green type cannot be supplied.

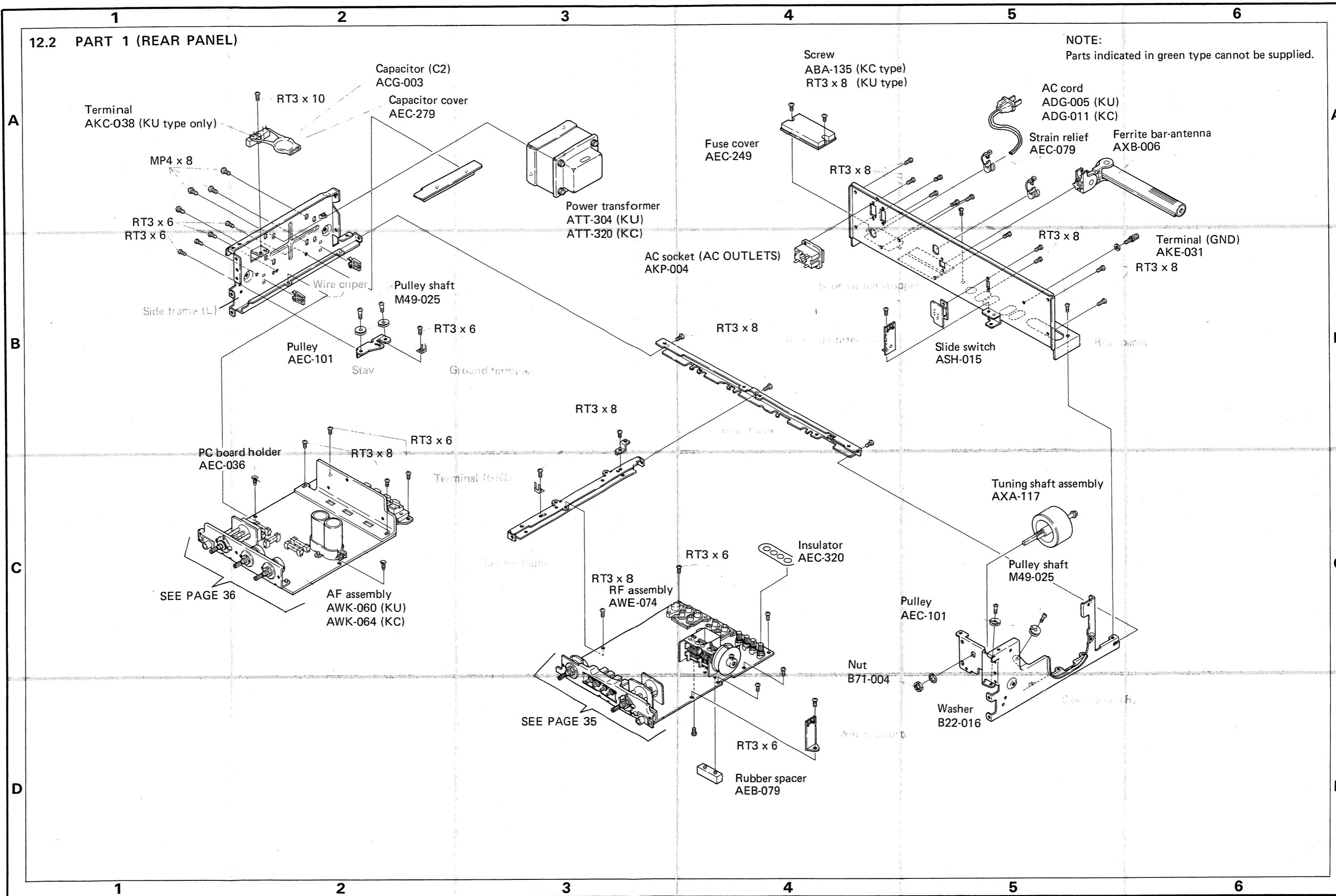

12.3 RF ASSEMBLY (AWE-074)

NOTE:
Parts indicated in green type cannot be supplied.

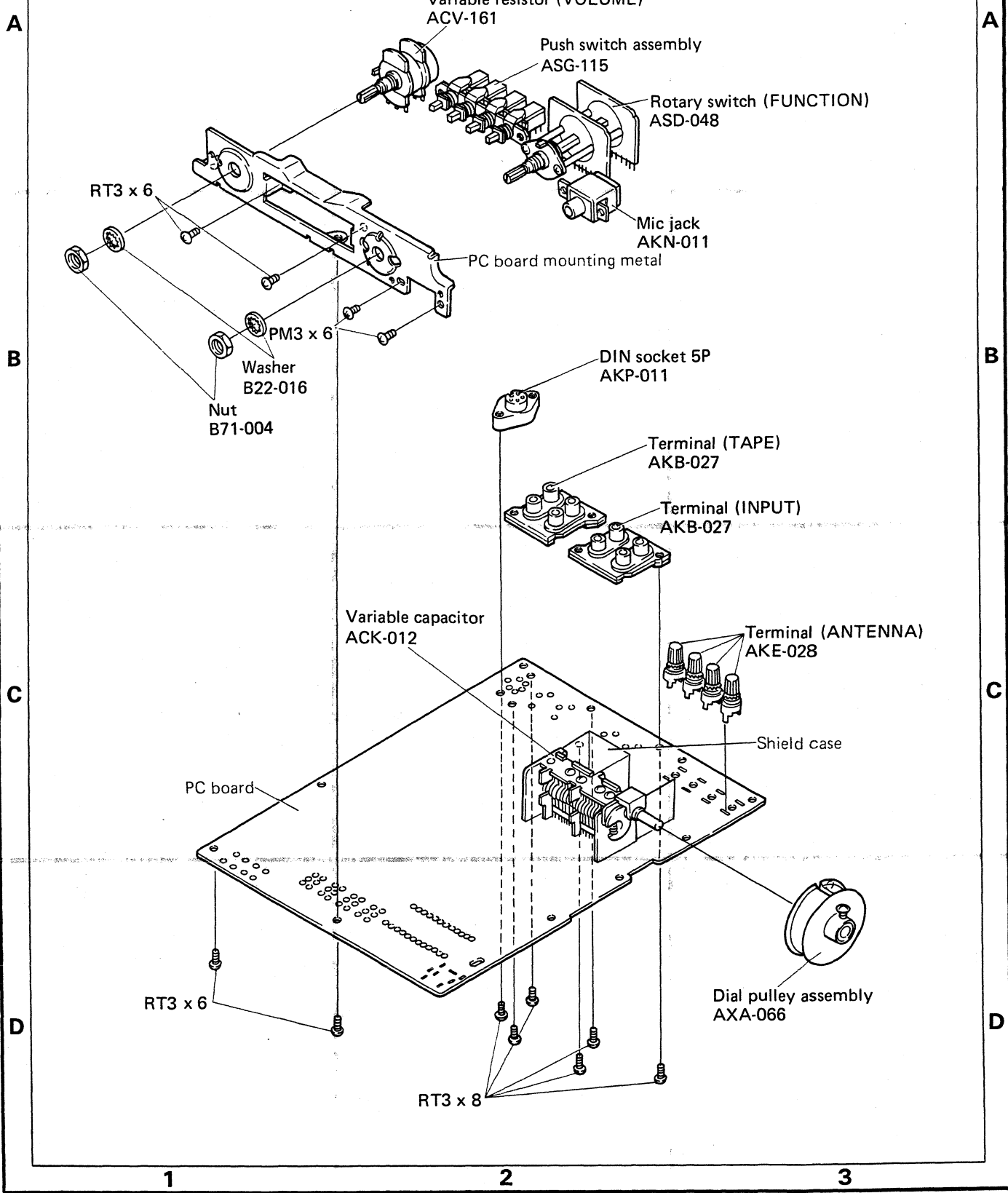

12.3 AF ASSEMBLY (AWK-060) KU Type
(AWK-064) KC TYPE

NOTE:
Parts indicated in green type cannot be supplied.

Capacitor (C1) Cover
ACG-001 (KU), AEC-294 (KU type)
ACG-003 (KC), AEC-279 (KC type)

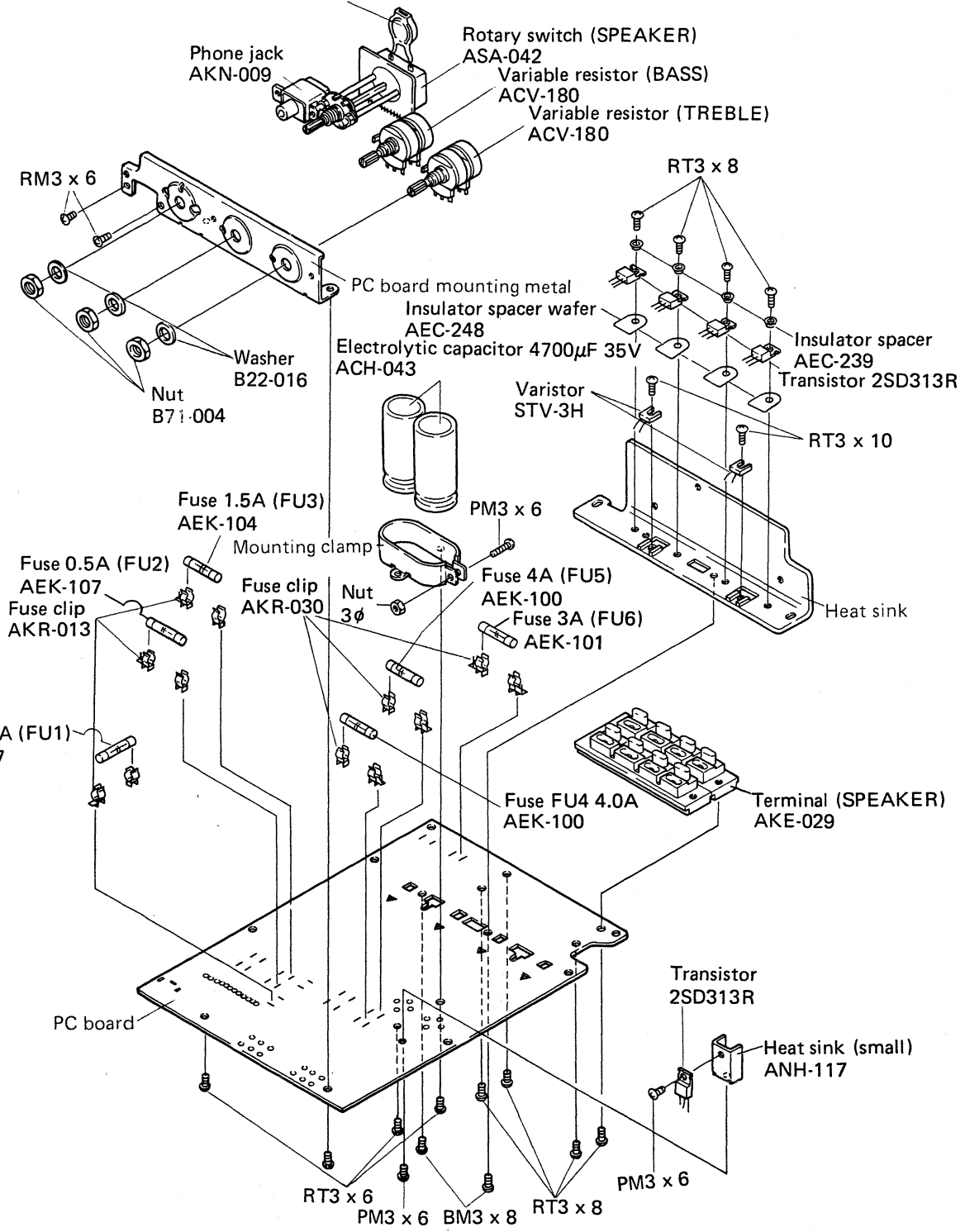

A

A

B

B

C

C

D

D

13. SCHEMATIC DIAGRAMS, P.C. BOARD PATTERNS AND PARTS LISTS

NOTE:

Capacitors: in μF unless otherwise noted p : pF

Resistors: in Ω , 1/4W unless otherwise noted k : k Ω , M : M Ω

13.1 MISCELLANEOUS PARTS LIST

KU TYPE

LAMPS

Symbol	Description	Part No.
PL1	Lamp assembly	AEL-060
PL2	Lamp assembly	AEL-060
PL3	Lamp assembly	AEL-060
PL4	Lamp with leads	AEL-062
PL5	Lamp with leads	AEL-061

KC TYPE

LAMPS

Symbol	Description	Part No.
PL1	Lamp assembly	AEL-060
PL2	Lamp assembly	AEL-060
PL3	Lamp assembly	AEL-060
PL4	Lamp with leads	AEL-062
PL5	Lamp with leads	AEL-061

FUSES

Symbol	Description	Part No.
FU1	Fuse 0.5A	AEK-107
FU2	Fuse 0.5A	AEK-107
FU3	Fuse 1.5A	AEK-104
FU4	Fuse 4A	AEK-100
FU5	Fuse 4A	AEK-100
FU6	Fuse 3A	AEK-101

FUSES

Symbol	Description	Part No.
FU1	Fuse 0.5A	AEK-107
FU2	Fuse 0.5A	AEK-107
FU3	Fuse 1.5A	AEK-104
FU4	Fuse 4A	AEK-100
FU5	Fuse 4A	AEK-100
FU6	Fuse 3A	AEK-101

COIL AND TRANSFORMER

Symbol	Description	Part No.
	Ferrite bar antenna	AXB-006
	Power transformer	ATT-304

COIL AND TRANSFORMER

Symbol	Description	Part No.
	Ferrite bar antenna	AXB-006
	Power transformer	ATT-320

RESISTOR

Symbol	Description	Part No.
VR1	Variable resistor (BALANCE 1M Ω)	ACV-020

RESISTOR

Symbol	Description	Part No.
VR1	Variable resistor (BALANCE 1M Ω)	ACV-020

CAPACITORS

Symbol	Description	Part No.
C1	Ceramic 0.01 250V	ACG-001
C2	Ceramic 0.01 125V	ACG-003

CAPACITORS

Symbol	Description	Part No.
C1	Ceramic 0.01 125V	ACG-003
C2	Ceramic 0.01 125V	ACG-003

13.2 EXTERIOR VIEW OF TRANSISTORS AND ICS

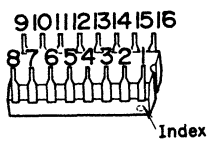
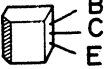
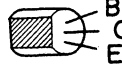
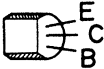
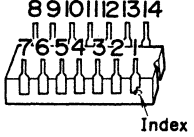
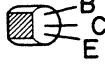
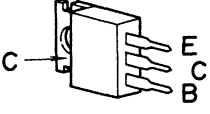
<p>2SK55</p> 	<p>HA1137 HA1138</p> 
<p>2SC535</p> 	<p>2SC1384</p> 
<p>2SA725</p> 	<p>HA1156</p> 
<p>2SC1222 2SC945A 2SC1318A 2SA720A 2SC1775A</p> 	<p>2SD313R</p> 

13.3 SCHEMATIC DIAGRAM

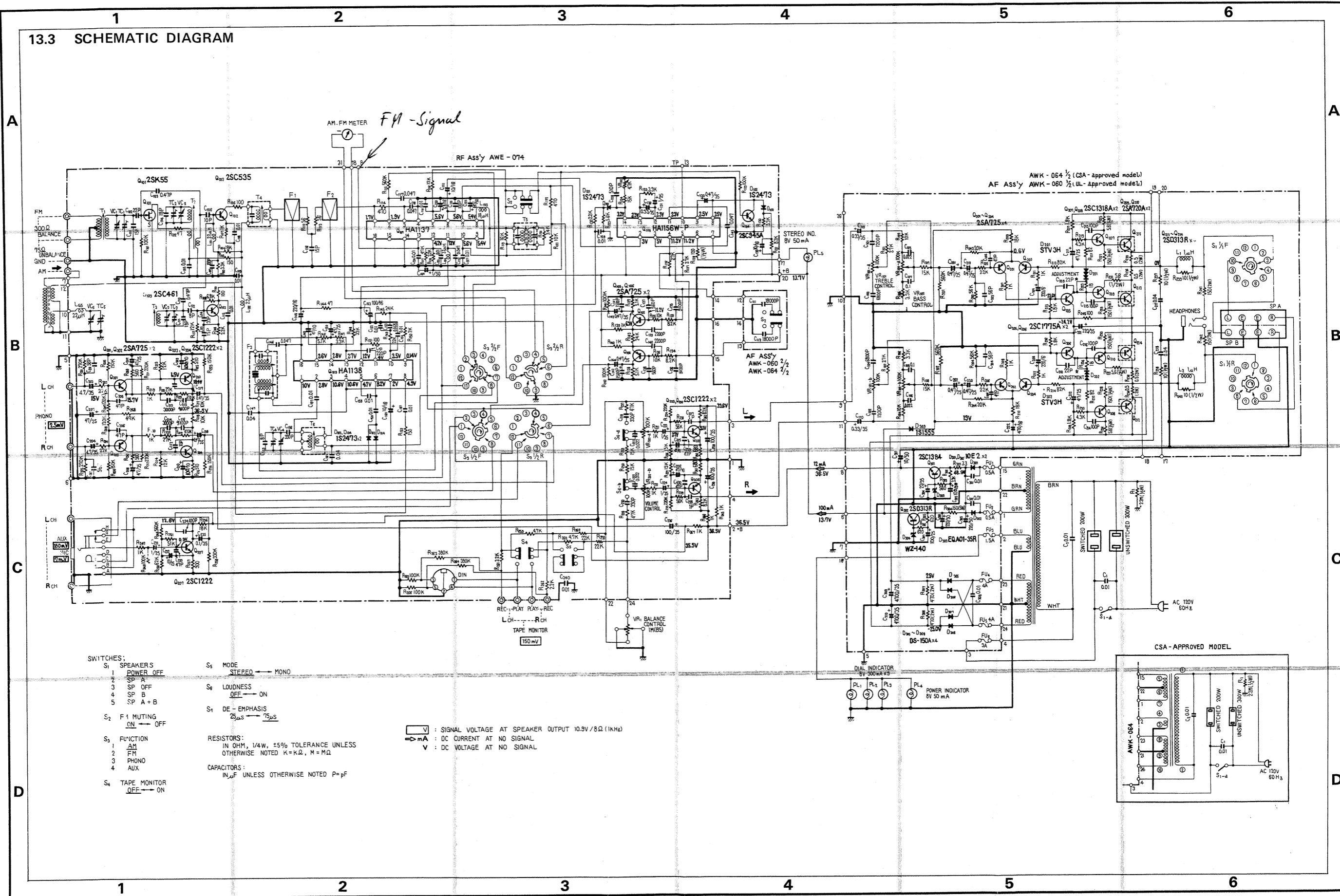

- SWITCHES:
- S₁ SPEAKERS POWER OFF
 - S₂ SP A
 - S₃ SP OFF
 - S₄ SP B
 - S₅ SP A + B
 - S₆ F1 MUTING ON → OFF
 - S₇ FUNCTION 1 AM, 2 FM, 3 PHONO, 4 AUX
 - S₈ TAPE MONITOR OFF → ON
 - S₉ MODE STEREO → MONO
 - S₁₀ LOUDNESS OFF → ON
 - S₁₁ DE-EMPHASIS 25μs → 75μs

- RESISTORS:
IN OHM, 1/4W, ±5% TOLERANCE UNLESS OTHERWISE NOTED K=KΩ, M=MΩ
- CAPACITORS:
IN μF UNLESS OTHERWISE NOTED P=pF

⊖ : SIGNAL VOLTAGE AT SPEAKER OUTPUT 10.9V/8Ω (1kHz)
 mA : DC CURRENT AT NO SIGNAL
 V : DC VOLTAGE AT NO SIGNAL

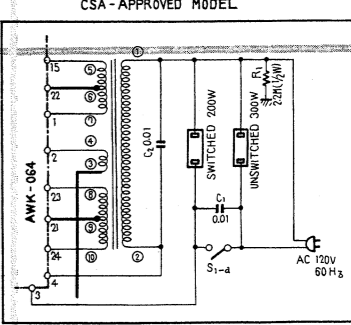

13.4 RF ASSEMBLY (AWE-074)

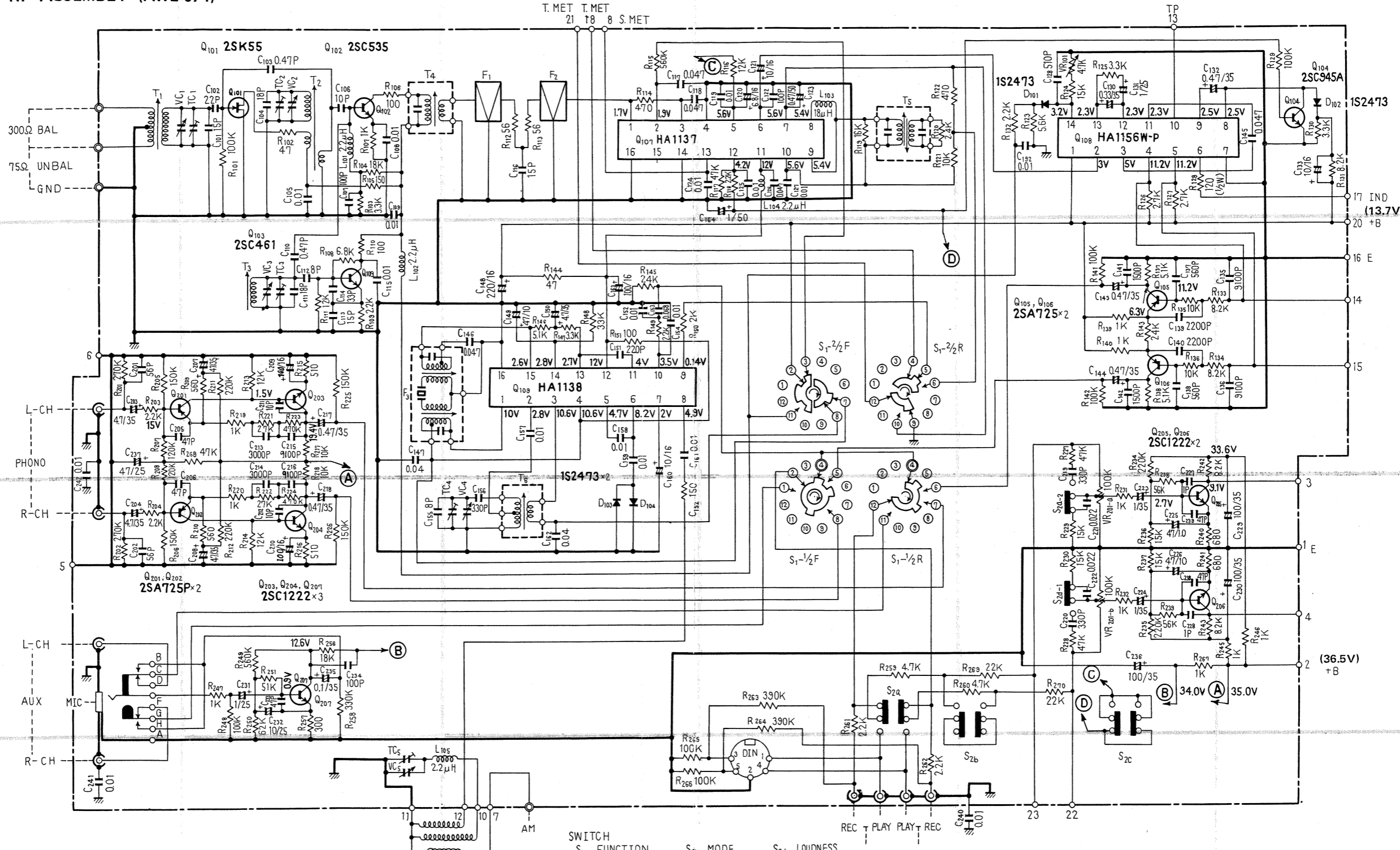

- SWITCH
- | | | | |
|------------------------------|---------------------------|--------------------------|---------------|
| S ₁ FUNCTION | S _{2b} MODE | S _{2d} LOUDNESS | L-CH --- R-CH |
| 1) AM | 1) STEREO | 1) OFF | TAPE MONITOR |
| 2) FM | 2) MONO | 2) ON | |
| 3) PHONO | | | |
| 4) AUX | S _{2c} FM-MUTING | | |
| S _{2a} TAPE MONITOR | 1) ON | | |
| 1) OFF | 2) OFF | | |
| 2) ON | | | |

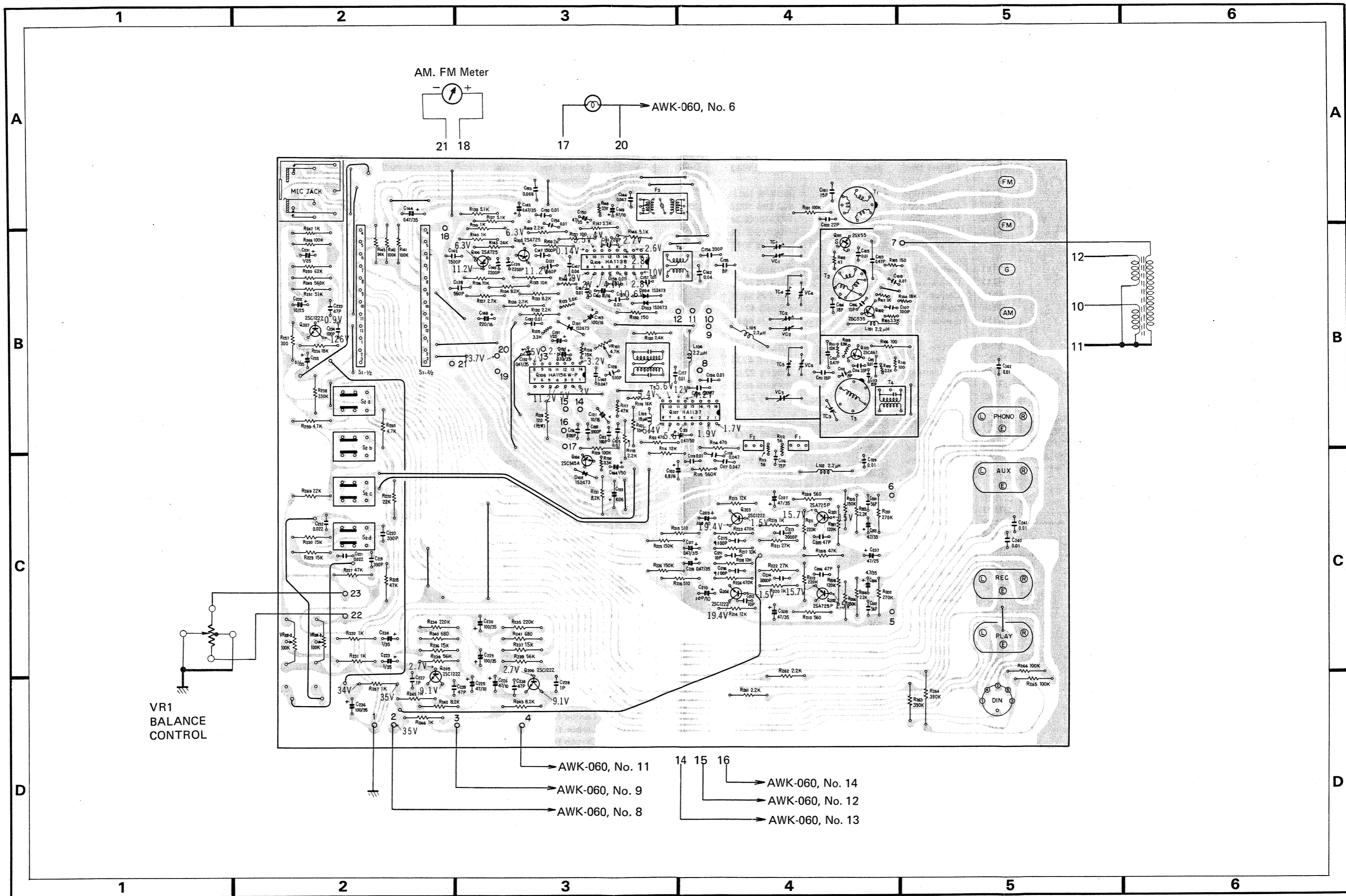

AM. FM Meter

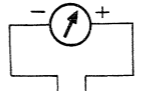

AWK-060, No. 6

21 18

17 20

VR1
BALANCE
CONTROL

AWK-060, No. 11

AWK-060, No. 9

AWK-060, No. 8

14 15 16

AWK-060, No. 14

AWK-060, No. 12

AWK-060, No. 13

Parts List of RF Assembly (AWE-074)

SEMICONDUCTORS

Symbol	Description	Part No.
Q101	FET	2SK55-D
Q102	Transistor	2SC535-A
Q103	Transistor	2SC461-B
Q104	Transistor	2SC945A-Q
Q105	Transistor	2SA725-F (2SA842-BL)
Q106	Transistor	2SA725-F (2SA842-BL)
Q107	IC	HA1137
Q108	IC	HA1156W-P
Q109	IC	HA1138
Q201	Transistor	2SA725P-F
Q202	Transistor	2SA725P-F
Q203	Transistor	(or 2SC1919) 2SC1222-U
Q204	Transistor	(or 2SC1919) 2SC1222-U
Q205	Transistor	(or 2SC1919) 2SC1222-U
Q206	Transistor	(or 2SC1919) 2SC1222-U
Q207	Transistor	(or 2SC1919) 2SC1222-U
D101	Diode	1S2473 (1S2076)
D102	Diode	1S2473 (1S2076)
D103	Diode	1S2473 (1S2076)
D104	Diode	1S2473 (1S2076)

SWITCHES AND COILS

Symbol	Description	Part No.
S1	Rotary Switch (FUNCTION)	ASD-048
S2	Push Switch assembly (TAPE MONITOR) (MODE) (FM-MUTING) (LOUDNESS)	ASG-115
T1	FM antenna coil	ATC-030
T2	FM RF coil	ATC-024
T3	FM oscillator coil	ATC-025
T4	FM matching transformer	ATE-026
T5	FM IF transformer	T73-035
T6	AM oscillator coil	ATB-013
F1	FM ceramic filter	ATF-013
F2	FM ceramic filter	ATF-013
F3	AM ceramic filter	ATF-027
L101	RF choke coil 2.2μH	T24-028
L102	RF choke coil 2.2μH	T24-028
L103	Micro inductor 18μH	ATH-007
L104	RF choke coil 2.2μH	T24-028
L105	RF choke coil 2.2μF	T24-028

RESISTORS

Symbol	Description	Part No.
R101	Carbon film 100k	RD½PS 104J
R102	Carbon film 47	RD½PS 470J
R103	Carbon film 3.3k	RD½VS 332J
R104	Carbon film 18k	RD½VS 183J
R105	Carbon film 150	RD½VS 151J
R106	Carbon film 100	RD½PS 101J
R107	Carbon film 1k	RD½VS 102J
R108	Carbon film 6.8k	RD½VS 682J
R109	Carbon film 2.2k	RD½VS 222J
R110	Carbon film 100	RD½VS 101J
R111	Carbon film 12k	RD½VS 123J
R112	Carbon film 56	RD½VS 560J
R113	Carbon film 56	RD½VS 560J
R114	Carbon film 470	RD½PS 471J
R115	Carbon film 560k	RD½VS 564J
R116	Carbon film 12k	RD½PS 123J
R117	Carbon film 47k	RD½VS 473J
R118	Carbon film 2.2k	RD½PS 222J
R119	Carbon film 16k	RD½VS 163J
R120	Carbon film 2.4k	RD½PS 242J
R121	Carbon film 10k	RD½PS 103J
R122	Carbon film 470	RD½PS 471J
R123	Carbon film 5.6k	RD½VS 562J
R124	Carbon film 15k	RD½VS 153J
R125	Carbon film 3.3k	RD½VS 332J
R126	Carbon film 2.7k	RD½PS 272J
R127	Carbon film 2.7k	RD½PS 272J
R128	Carbon film 120	RD½PS 121J
R129	Carbon film 100k	RD½PS 104J
R130	Carbon film 3.3k	RD½VS 332J
R131	Carbon film 8.2k	RD½PS 822J
R132	Carbon film 2.2k	RD½PS 222J
R133	Carbon film 8.2k	RD½PS 822J
R134	Carbon film 8.2k	RD½PS 822J
R135	Carbon film 10k	RD½PS 103J
R136	Carbon film 10k	RD½PS 103J
R137	Carbon film 5.1k	RD½PS 512J
R138	Carbon film 5.1k	RD½PS 512J
R139	Carbon film 1k	RD½PS 102J
R140	Carbon film 1k	RD½PS 102J
R141	Carbon film 100k	RD½PS 104J
R142	Carbon film 100k	RD½PS 104J
R143	Carbon film 24k	RD½PS 243J
R144	Carbon film 47	RD½VS 470J
R145	Carbon film 24k	RD½PS 243J
R146	Carbon film 5.1k	RD½PS 512J
R147	Carbon film 3.3k	RD½PS 332J
R148	Carbon film 33k	RD½VS 333J
R149	Carbon film 2.2k	RD½PS 222J
R150	Carbon film 2k	RD½PS 202J

Symbol	Description	Part No.
R151	Carbon film 100	RD½PS 101J
R152	Carbon film 150	RD½PS 151J
R201	Carbon film 270k	RD½PS 274J
R202	Carbon film 270k	RD½PS 274J
R203	Carbon film 2.2k	RD½PS 222J
R204	Carbon film 2.2k	RD½PS 222J
R205	Carbon film 150k	RD½PS 154JNL
R206	Carbon film 150k	RD½PS 154JNL
R207	Carbon film 120k	RD½PS 124JNL
R208	Carbon film 120k	RD½PS 124JNL
R209	Carbon film 560	RD½PS 561J
R210	Carbon film 560	RD½PS 561J
R211	Carbon film 220k	RD½PS 224J
R212	Carbon film 220k	RD½PS 224J
R213	Carbon film 12k	RD½PS 123J
R214	Carbon film 12k	RD½PS 123J
R215	Carbon film 510	RD½PS 511J
R216	Carbon film 510	RD½PS 511J
R217	Carbon film 10k	RD½PS 103J
R218	Carbon film 10k	RD½PS 103J
R219	Carbon film 1k	RD½PS 102J
R220	Carbon film 1k	RD½PS 102J
R221	Carbon film 27k	RD½PS 273J
R222	Carbon film 27k	RD½PS 273J
R223	Carbon film 470k	RD½PS 474J
R224	Carbon film 470k	RD½PS 474J
R225	Carbon film 150k	RD½PS 154J
R226	Carbon film 150k	RD½PS 154J
R227	Carbon film 47k	RD½PS 473J
R228	Carbon film 47k	RD½PS 473J
R229	Carbon film 15k	RD½PS 153J
R230	Carbon film 15k	RD½PS 153J
R231	Carbon film 1k	RD½PS 102J
R232	Carbon film 1k	RD½PS 102J
R233		
R234	Carbon film 220k	RD½PS 224J
R235	Carbon film 220k	RD½PS 224J
R236	Carbon film 15k	RD½PS 153J
R237	Carbon film 15k	RD½PS 153J
R238	Carbon film 56k	RD½PS 563J
R239	Carbon film 56k	RD½PS 563J
R240	Carbon film 680	RD½PS 681J
R241	Carbon film 680	RD½PS 681J
R242	Carbon film 8.2k	RD½PS 822J
R243	Carbon film 8.2k	RD½PS 822J
R244		
R245	Carbon film 1k	RD½PS 102J
R246	Carbon film 1k	RD½PS 102J
R247	Carbon film 1k	RD½PS 102J

Symbol	Description	Part No.
R248	Carbon film 100k	RD½PS 104J
R249	Carbon film 560k	RD½PS 564J
R250	Carbon film 62k	RD½PS 623J
R251	Carbon film 51k	RD½PS 513J
R256	Carbon film 18k	RD½PS 183J
R257	Carbon film 300	RD½PS 301J
R258	Carbon film 330k	RD½PS 334J
R259	Carbon film 4.7k	RD½PS 472J
R260	Carbon film 4.7k	RD½PS 472J
R261	Carbon film 2.2k	RD½PS 222J
R262	Carbon film 2.2k	RD½PS 222J
R263	Carbon film 390k	RD½PS 394J
R264	Carbon film 390k	RD½PS 394J
R265	Carbon film 100k	RD½PS 104J
R266	Carbon film 100k	RD½PS 104J
R267	Carbon film 1k	RD½PS 102J
R268	Carbon film 47k	RD½PS 473J
R269	Carbon film 22k	RD½PS 223J
R270	Carbon film 22k	RD½PS 223J

CAPACITORS

Symbol	Description	Part No.
C101	Ceramic 15p 50V	CCDSH 150K 50
C102	Ceramic 22p 50V	CCDSL 220K 50
C103	Ceramic 0.47p 500V	CGB R47K500
C104	Ceramic 18p 50V	CCDTH 180K 50
C105	Ceramic 0.01 50V	CKDYF 103Z 50
C106	Ceramic 10p 50V	CCDSL 100K 50
C107	Ceramic 100p 50V	CCDSL 101K 50
C108	Ceramic 0.01 50V	CKDYF 103Z 50
C109	Ceramic 0.01 50V	CKDYF 103Z 50
C110	Ceramic 0.47p 500V	CGB R47K500
C111	Ceramic 18p 50V	CCDPH 180K 50
C112	Ceramic 8p 50V	CCDSH 080F 50
C113	Ceramic 15p 50V	CCDCH 150K 50
C114	Ceramic 33p 50V	CCDCH 330K 50
C115	Ceramic 0.01 50V	CKDYB 103K 50
C116	Ceramic 15p 50V	CCDSL 150K 50
C117	Ceramic 0.047 50V	CKDYF 473Z 50
C118	Ceramic 0.047 50V	CKDYF 473Z 50
C119	Ceramic 0.01 50V	CKDYF 103Z 50
C120	Electrolytic 6.8 16V	CSZA 6R8M 16
C121	Electrolytic 10 16V	CEA 100P 16
C122	Ceramic 100p 50V	CCDSL 101K 50
C123	Electrolytic 0.47 50V	CEA R47P 50

Circuit Diagram of ICs
HA1137 (FM IF IC)

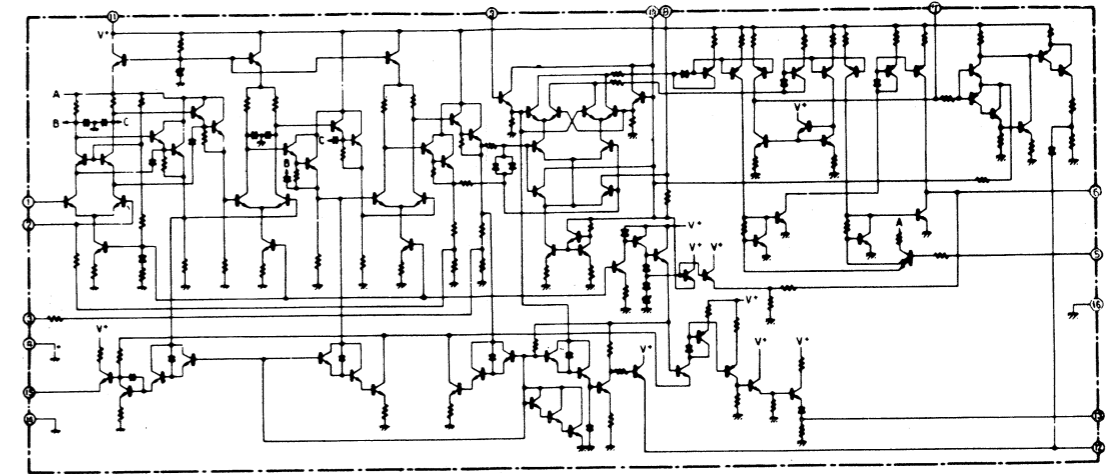

HA1156 (FM MPX IC)

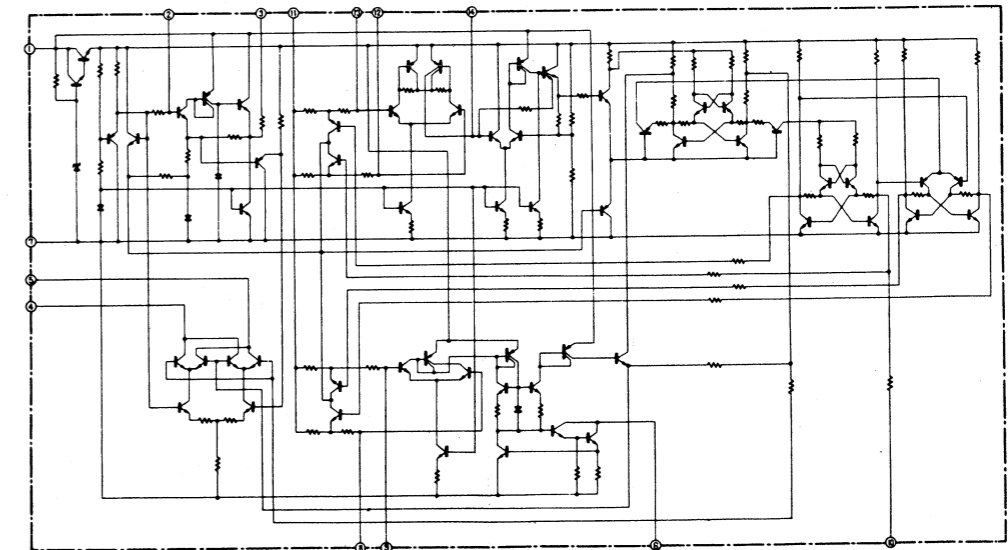

HA1138 (AM IC)

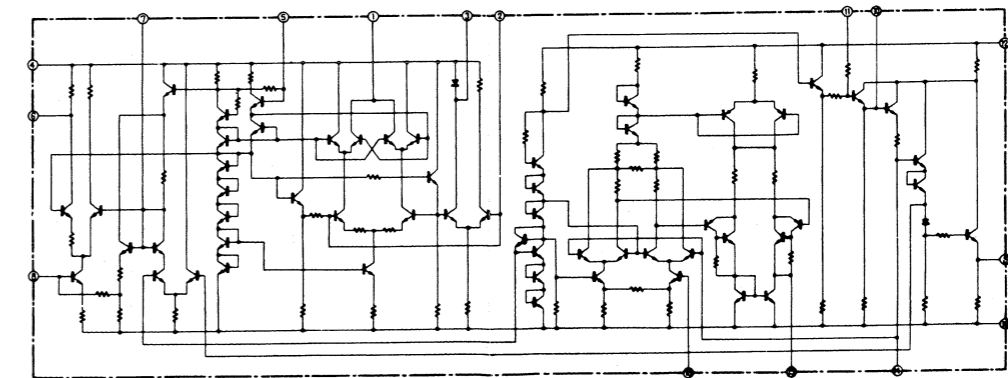

Symbol	Description	Part No.
C124	Ceramic 0.01 50V	CKDYF 103Z 50
C125	Ceramic 0.01 50V	CKDYF 103Z 50
C126	Ceramic 0.047 50V	CKDYF 473Z 50
C127	Ceramic 0.01 50V	CKDYF 103Z 50
C128	Polystyrene film 510p 50V	CQSH 511J 50
C129	Polystyrene film	
C130	Electrolytic 0.33 35V	CSZA R33M 35
C131	Electrolytic 1 25V	CSZA 010M 25
C132	Electrolytic 0.47 35V	CSZA R47M 35
C133	Electrolytic 10 16V	CEA 100P 16
C135	Ceramic 9100p 50V	CKDYA 912J 50
C136	Ceramic 9100p 50V	CKDYA 912J 50
C137	Ceramic 560p 50V	CKDYB 561K 50
C138	Ceramic 560p 50V	CKDYB 561K 50
C139	Ceramic 2200p 50V	CKDYB 222K 50
C140	Ceramic 2200p 50V	CKDYB 222K 50
C141	Ceramic 1500p 50V	CKDYB 152K 50
C142	Ceramic 1500p 50V	CKDYB 152K 50
C143	Electrolytic 0.47 35V	CSZA R47M 35
C144	Electrolytic 0.47 35V	CSZA R47M 35
C145	Mylar 0.047 50V	CQMA 473J 50
C146	Ceramic 0.047 50V	CKDYF 473Z 50
C147	Ceramic 0.04 50V	CKDYF 403Z 50
C148	Electrolytic 220 16V	CEA 221P 16
C149	Electrolytic 47 10V	CEA 470P 10
C150	Electrolytic 4.7 35V	CEA 4R7P 35
C151	Ceramic 220p 50V	CCDSL 221K 50
C152	Ceramic 0.01 50V	CKDYF 103Z 50
C153	Mylar 0.068 50V	CQMA 683J 50
C154	Ceramic 0.01 50V	CKDYF 103Z 50
C155	Ceramic 8p 50V	CCDZL 080F 50
C156	Polystyrene film 330p 50V	CQSA 331J 50
C157	Ceramic 0.01 50V	CKDYB 103K 50
C158	Ceramic 0.01 50V	CKDYF 103Z 50
C159	Ceramic 0.01 50V	CKDYF 103Z 50
C160	Electrolytic 10 16V	CEA 100P 16
C161	Ceramic 0.01 50V	CKDYF 103Z 50
C162	Ceramic 0.04 50V	CKDYF 403Z 50
C163	Electrolytic 100 16V	CEA 101P 16
C164	Electrolytic 1 50V	CEA 010P 50
C201	Ceramic 56p 50V	CCDSL 560K 50
C202	Ceramic 56p 50V	CCDSL 560K 50
C203	Electrolytic 4.7 35V	CSZA 4R7M 35
C204	Electrolytic 4.7 35V	CSZA 4R7M 35
C205	Ceramic 47p 50V	CCDSL 470K 50
C206	Ceramic 47p 50V	CCDSL 470K 50
C207	Electrolytic 47 35V	CEA 470P 35
C208	Electrolytic 47 35V	CEA 470P 35
C209	Electrolytic 100 10V	CEA 101P 10
C210	Electrolytic 100 10V	CEA 101P 10

Symbol	Description	Part No.
C211	Ceramic 10p 50V	CCDSL 100F 50
C212	Ceramic 10p 50V	CCDSL 100F 50
C213	Ceramic 3000p 50V	CKDYA 302J 50
C214	Ceramic 3000p 50V	CKDYA 302J 50
C215	Ceramic 9100p 50V	CKDYA 912J 50
C216	Ceramic 9100p 50V	CKDYA 912J 50
C217	Electrolytic 0.47 35V	CSZA R47M 35
C218	Electrolytic 0.47 35V	CSZA R47M 35
C219	Ceramic 330p 50V	CCDSL 331K 50
C220	Ceramic 330p 50V	CCDSL 331K 50
C221	Mylar 0.022 50V	CQMA 223J 50
C222	Mylar 0.022 50V	CQMA 223J 50
C223	Electrolytic 1 35V	CSZA 010M 35
C224	Electrolytic 1 35V	CSZA 010M 35
C225	Electrolytic 47 10V	CEA 470P 10
C226	Electrolytic 47 10V	CEA 470P 10
C227	Ceramic 1p 50V	CCDSL 010K 50
C228	Ceramic 1p 50V	CCDSL 010K 50
C229	Electrolytic 100 35V	CEA 101P 35
C230	Electrolytic 100 35V	CEA 101P 35
C231	Electrolytic 1 25V	CSZA 010M 25
C232	Electrolytic 10 25V	CEA 100P 25
C233	Ceramic 47p 50V	CCDSL 470K 50
C234	Ceramic 100p 50V	CCDSL 101K 50
C235	Electrolytic 0.1 35V	CSZA 0R1M 35
C236	Electrolytic 100 35V	CEA 101P 35
C237	Electrolytic 47 25V	CEA 470P 25
C238	Ceramic 47p 50V	CCDSL 470K 50
C239	Ceramic 47p 50V	CCDSL 470K 50
C240	Ceramic 0.01 50V	CKDYF 103Z 50
C241	Ceramic 0.01 50V	CKDYF 103Z 50
C242	Ceramic 0.01 50V	CKDYF 103Z 50

OTHERS

Symbol	Description	Part No.
	5P DIN type Terminal (INPUT, TAPE)	AKP-011 AKB-027
VR101	Semi fixed Volume	C92-051
VR201	Variable resistor (VOLUME)	ACV-161
	Variable capacitor	ACK-012
	Semi fixed VC.	ACM-006
	Phone jack (MIC)	AKN-011

13.5 AF ASSEMBLY (AWK-060) KU Type, (AWK-064) KC Type

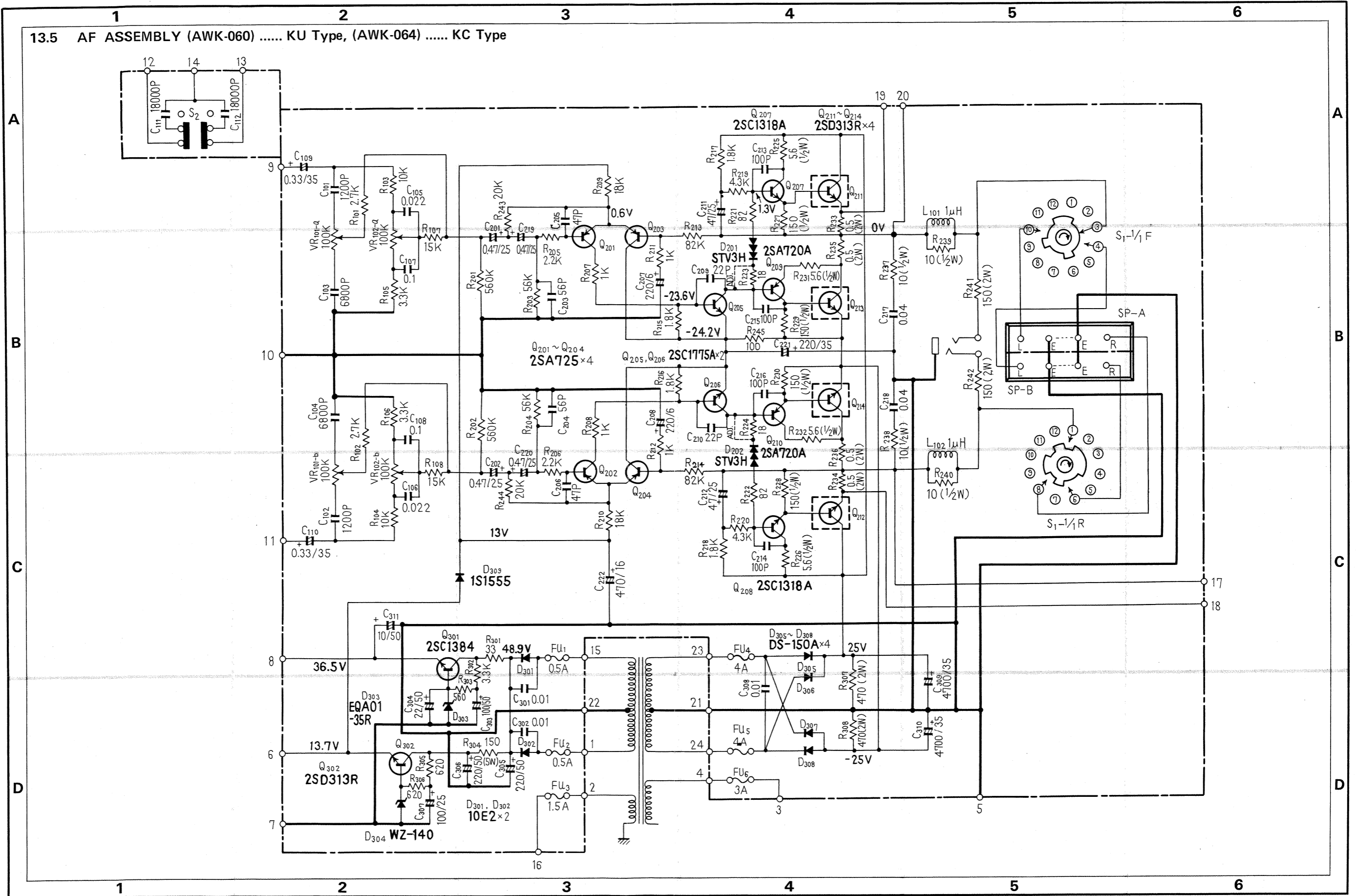

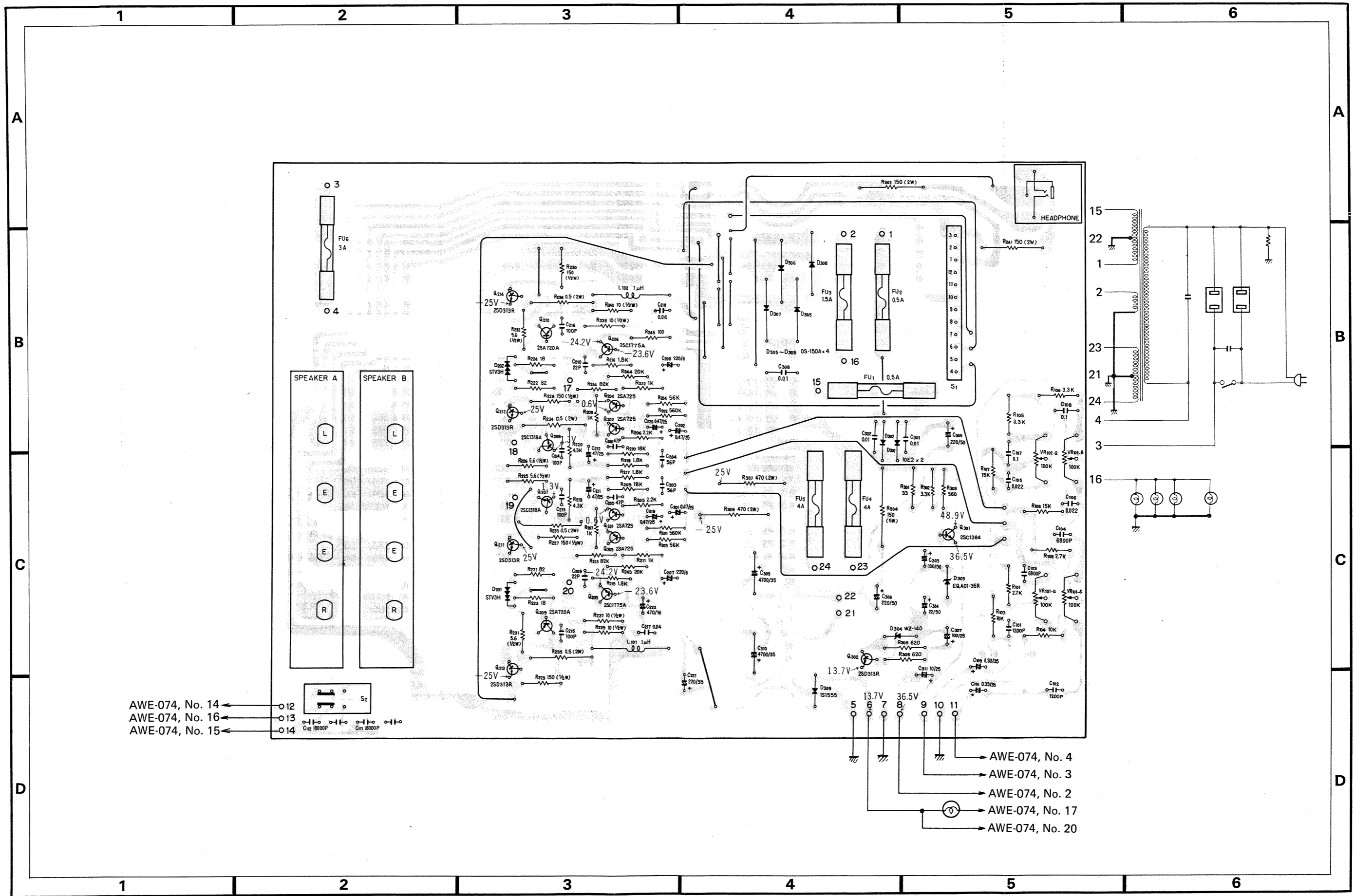

AWE-074, No. 14 ← o 12
 AWE-074, No. 16 ← o 13
 AWE-074, No. 15 ← o 14

AWE-074, No. 4
 AWE-074, No. 3
 AWE-074, No. 2
 AWE-074, No. 17
 AWE-074, No. 20

Parts List of AF Assembly (AWK-060)

SEMICONDUCTORS

Symbol	Description	Part No.
Q201	Transistor	2SA725-F (2SA640-F)
Q202	Transistor	2SA725-F (2SA640-F)
Q203	Transistor	2SA725-F (2SA640-F)
Q204	Transistor	2SA725-F (2SA640-F)
Q205	Transistor	2SC1775A-E
Q206	Transistor	2SC1775A-E
Q207	Transistor	2SC1318A-S (2SC1211-D)
Q208	Transistor	2SC1318A-S (2SC1211-D)
Q209	Transistor	2SA720A-S (2SA697-D)
Q210	Transistor	2SA720A-S (2SA697-D)
Q211	Transistor	2SD313R-D (2SD526-D)
Q212	Transistor	2SD313R-D (2SD526-D)
Q213	Transistor	2SD313R-D (2SD526-D)
Q214	Transistor	2SD313R-D (2SD526-D)
Q301	Transistor	2SC1384-Q
Q302	Transistor	2SD313R-D (2SD526-D)
D201	Varistor	STV-3H
D202	Varistor	STV-3H
D301	Diode	10E2
D302	Diode	10E2
D303	Zener diode	EQA01-35R
D304	Zener diode	WZ-140
D305	Diode	DS-150A (30D2)
D306	Diode	DS-150A (30D2)
D307	Diode	DS-150A (30D2)
D308	Diode	DS-150A (30D2)
D309	Diode	1S1555 (1S2473)

SWITCHES AND COILS

Symbol	Description	Part No.
	Rotary Switch (SPEAKERS)	ASA-042
	Slide Switch (DE-EMPHASIS)	ASH-015
L101	AF choke coil 1μH	ATH-011
L102	AF choke coil 1μH	ATH-011

RESISTORS

Symbol	Description	Part No.
VR101	Variable 100kΩ-A dual (TREBLE)	ACV-180
VR102	Variable 100kΩ-A dual (BASS)	ACV-180
R101	Carbon film 2.7k	RD½PS 272J
R102	Carbon film 2.7k	RD½PS 272J
R103	Carbon film 10k	RD½PS 103J
R104	Carbon film 10k	RD½PS 103J
R105	Carbon film 3.3k	RD½PS 332J
R106	Carbon film 3.3k	RD½PS 332J
R107	Carbon film 15k	RD½PS 153J
R108	Carbon film 15k	RD½PS 153J
R201	Carbon film 560k	RD½PS 564J
R202	Carbon film 560k	RD½PS 564J
R203	Carbon film 56k	RD½PS 563J
R204	Carbon film 56k	RD½PS 563J
R205	Carbon film 2.2k	RD½PS 222J
R206	Carbon film 2.2k	RD½PS 222J
R207	Carbon film 1k	RD½PS 102J
R208	Carbon film 1k	RD½PS 102J
R209	Carbon film 18k	RD½PS 183J
R210	Carbon film 18k	RD½PS 183J
R211	Carbon film 1k	RD½PS 102J
R212	Carbon film 1k	RD½PS 102J
R213	Carbon film 82k	RD½PS 823J
R214	Carbon film 82k	RD½PS 823J
R215	Carbon film 1.8k	RD½PS 182J
R216	Carbon film 1.8k	RD½PS 182J
R217	Carbon film 1.8k	RD½PS 182J
R218	Carbon film 1.8k	RD½PS 182J
R219	Carbon film 4.3k	RD½PS 432J
R220	Carbon film 4.3k	RD½PS 432J
R221	Carbon film 82	RD½PS 820J
R222	Carbon film 82	RD½PS 820J
R223	Carbon film 18	RD½PS 180J
R224	Carbon film 18	RD½PS 180J
R225	Carbon film 5.6 ½W	RD½PSF 5R6J
R226	Carbon film 5.6 ½W	RD½PSF 5R6J
R227	Carbon film 150 ½W	RD½PSF 151J
R228	Carbon film 150 ½W	RD½PSF 151J
R229	Carbon film 150 ½W	RD½PSF 151J
R230	Carbon film 150 ½W	RD½PSF 151J
R231	Carbon film 5.6 ½W	RD½PSF 5R6J
R232	Carbon film 5.6 ½W	RD½PSF 5R6J
R233	Metal film 0.5 2W	RN2H 0R5K
R234	Metal film 0.5 2W	RN2H 0R5K
R235	Metal film 0.5 2W	RN2H 0R5K
R236	Metal film 0.5 2W	RN2H 0R5K
R237	Carbon film 10 ½W	RD½PSF 100J
R238	Carbon film 10 ½W	RD½PSF 100J
R239	Carbon film 10 ½W	RD½PS 100J
R240	Carbon film 10 ½W	RD½PS 100J

Symbol	Description	Part No.
R241	Metal oxide film 150 2W	RS2P 151J
R242	Metal oxide film 150 2W	RS2P 151J
R243	Carbon film 20k	RD½PS 203J
R244	Carbon film 20k	RD½PS 203J
R245	Carbon film 100	RD½PS 101J
R301	Carbon film 33	RD½PSF 330J
R302	Carbon film 3.3k	RD½PS 332J
R303	Carbon film 560	RD½PS 561J
R304	Wire wound 150 5W	RT5B 151K
R305	Carbon film 620	RD½PS 621J
R306	Carbon film 620	RD½PS 621J
R307	Metal oxide film 470 2W	RS2P 471J
R308	Metal oxide film 470 2W	RS2P 471J

CAPACITORS

Symbol	Description	Part No.
C101	Ceramic 1200p 50V	CKDYA 122J 50
C102	Ceramic 1200p 50V	CKDYA 122J 50
C103	Ceramic 6800p 50V	CKDYA 682J 50
C104	Ceramic 6800p 50V	CKDYA 682J 50
C105	Mylar 0.022 50V	CQMA 223J 50
C106	Mylar 0.022 50V	CQMA 223J 50
C107	Mylar 0.1 50V	CQMA 104J 50
C108	Mylar 0.1 50V	CQMA 104J 50
C109	Electrolytic 0.33 35V	CSZA R33M 35
C110	Electrolytic 0.33 35V	CSZA R33M 35
C111	Mylar 0.018 50V	CQMA 183J 50
C112	Mylar 0.018 50V	CQMA 183J 50
C201	Electrolytic 0.47 25V	CSZA R47M 25
C202	Electrolytic 0.47 25V	CSZA R47M 25
C203	Ceramic 56p 50V	CCDSL 560K 50
C204	Ceramic 56p 50V	CCDSL 560K 50
C205	Ceramic 47p 50V	CCDSL 470K 50
C206	Ceramic 47p 50V	CCDSL 470K 50
C207	Electrolytic 220 6V	CEA 221P 6
C208	Electrolytic 220 6V	CEA 221P 6
C209	Ceramic 22p 50V	CCDSL 220K 50
C210	Ceramic 22p 50V	CCDSL 220K 50
C211	Electrolytic 47 25V	CEA 470P 25
C212	Electrolytic 47 25V	CEA 470P 25
C213	Ceramic 100p 50V	CCDSL 101K 50
C214	Ceramic 100p 50V	CCDSL 101K 50
C215	Ceramic 100p 50V	CCDSL 101K 50
C216	Ceramic 100p 50V	CCDSL 101K 50
C217	Ceramic 0.04 50V	CKDYF 403Z 50
C218	Ceramic 0.04 50V	CKDYF 403Z 50
C219	Electrolytic 0.47 25V	CSZA R47M 25
C220	Electrolytic 0.47 25V	CSZA R47M 25

Symbol	Description	Part No.
C221	Electrolytic 220 35V	CEA 221P 35
C222	Electrolytic 470 16V	CEA 471P 16
C301	Ceramic 0.01 150V	ACG-004
C302	Ceramic 0.01 150V	ACG-004
C303	Electrolytic 100 50V	CEA 101P 50
C304	Electrolytic 22 50V	CEA 220P 50
C305	Electrolytic 220 50V	CEA 221P 50
C306	Electrolytic 220 50V	CEA 221P 50
C307	Electrolytic 100 25V	CEA 101P 25
C308	Ceramic 0.01 150V	ACG-004
C309	Electrolytic 4700 35V	ACH-043
C310	Electrolytic 4700 35V	ACH-043
C311	Electrolytic 10 50V	CEA 100P 50

OTHERS

Symbol	Description	Part No.
	Heat sink (small)	ANH-117
	Terminal (SPEAKERS)	AKE-029
	Phone jack	AKN-009
	Fuse clip	AKR-013
	Fuse clip	AKR-030

Parts List of AF Assembly (AWK-064)

The AF Assembly (AWK-064) which are not the same as those used in AWK-060 are listed below.

RESISTORS

Symbol	Description	Part No.
R239	Carbon film 10 ½W	RD½PSF 100J
R240	Carbon film 10 ½W	RD½PSF 100J

OTHERS

Symbol	Description	Part No.
	Fuse clip	AKR-013

14. PACKING

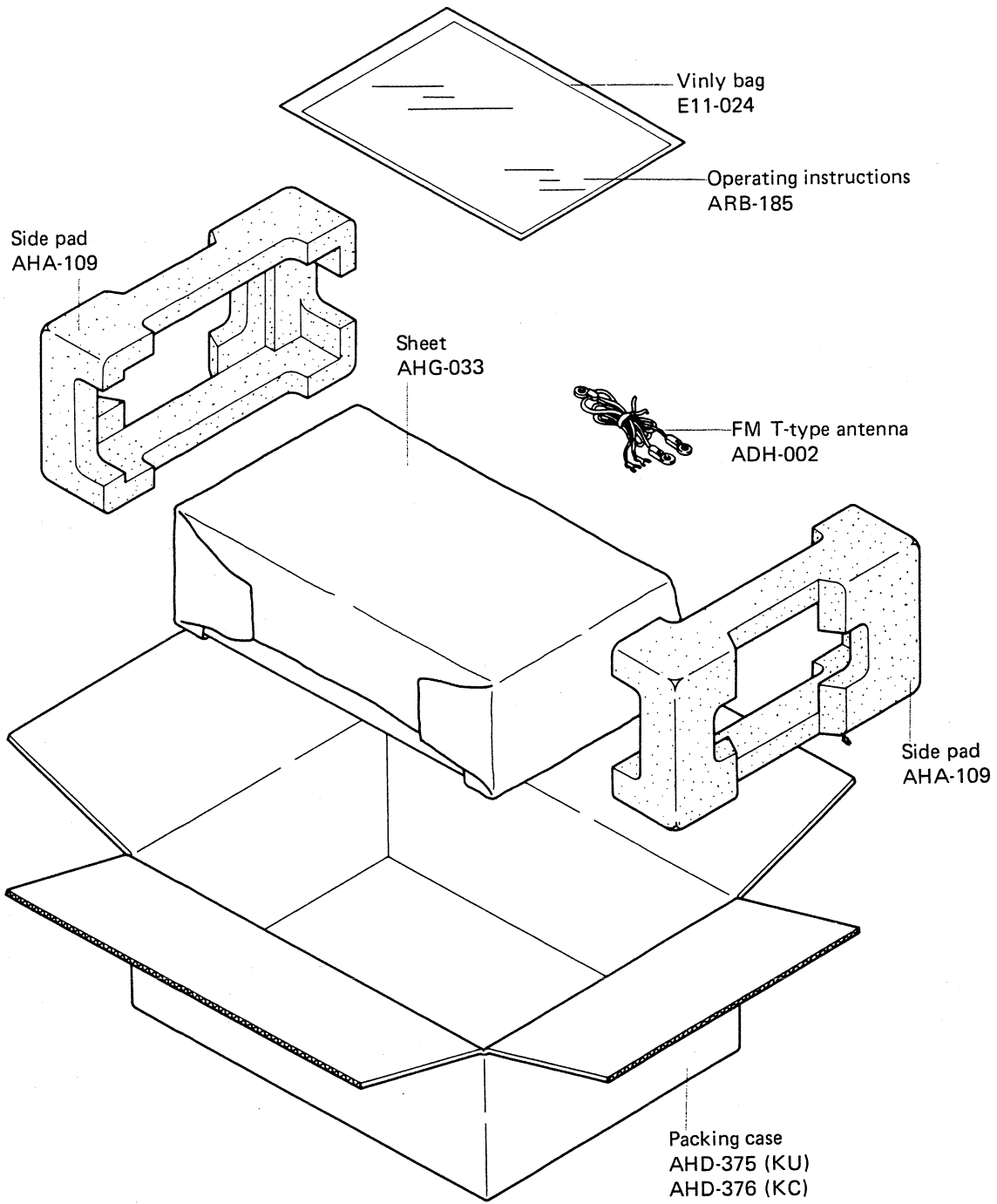

AM/FM STEREO RECEIVER

SX-450

HG, S

Additional

Service Manual

This Additional Service Manual provides only part that differ from those used in KU, KC types.

This Specifications of HG, S types are the same as KU, KC types except following section.

Power Requirements	KU, KC, 120V 60Hz HG; 220V/240V 50Hz S; 110V/120V/220V/240V 50/60Hz
Power Consumption	UL; 70W, 130W (Max.) 120VA HG, S; 130W

CONTRAST OF MISCELLANEOUS PART

FUSES

Symbol	Description	Part No.			Remarks
		KU, KC	HG	S	
F1-F2	Fuse 0.5A	AEK-107	AEK-401	AEK-107	
F3	Fuse 1.5A	AEK-104	AEK-104	
	Fuse 1.6A	AEK-405	
F4-F5	Fuse 4A	AEK-100	AEK-400	AEK-100	
	Fuse 3A	AEK-101	
	Fuse 1.6A	AEK-405	
	Fuse 1.5A	AEK-104	

TRANSFORMER

Symbol	Description	Part No.			Remarks
		KU, KC	HG	S	
	Power Transformer	ATT-304 (KU) ATT-320 (KC)	ATT-333	ATT-332	

RESISTOR

Symbol	Description	Part No.			Remarks
		KU, KC	HG	S	
R1	Carbon film 2.2M 1/2W	RD1/2PS 225J	

CAPACITORS

Symbol	Description	Part No.			Remarks
		KU, KC	HG	S	
C1	Ceramic 0.01 250V	ACG-001 (KU)	ACG-001	ACG-001	
	Ceramic 0.01 125V	ACG-003 (KC)	
C2	Ceramic 0.01 125V	ACG-003	
	Ceramic 0.01 250V	ACG-001	
	Ceramic 9100pF 50V	CKDYA 912J 50	
		CKDYA 912J 50	

SWITCHE

Symbol	Description	Part No.			Remarks
		KU, KC	HG	S	
	LINE VOLTAGE SELECTOR	AKR-031	4 position with Fuse holder 2 position
		AKX-037	
	Rotary Switch (SPEAKER)	ASA-042	ASA-045	ASA-044	
	Slide Switch	ASH-015	ASH-017	

P.C. BOARD ASSEMBLIES

Symbol	Description	Part No.			Remarks
		KU, KC	HG	S	
	RF assembly	AWE-074	AWE-074	AWE-074	
	AF assembly	AWK-060 (KU) AWK-064 (KC)	AWK-069	AWK-067	

OTHERS

Symbol	Description	Part No.			Remarks	
		KU, KC	HG	S		
L1	AC power cord	ADG-005	ADG-002	English German / French	
	Fuse clip	AKR-030 (KU) AKR-013 (KC)	AKR-013		
	Operating instructions	ARB-185	ARB-193 ARD-096	ARB-191		
	Top plate	ANE-120	ANE-131	ANE-131		
	Packing case	AHD-375 (KU) AHD-376 (KC)	AHD-377	AHD-375		
	Socket (FM antenna)	AKP-016		
	Ferrite Bar antenna	AXB-006	AXB-010	AXB-006		
	Ferry inductor	T24-030		
	Capacitor cover	AEC-279 (KU) AEC-294 (KU) AEC-279 (KC)	AEC-099	AEC-099		
	AC socket	AKP-004	AKP-008	AKP-004		AKP-008 (INLET)

PEAR PANEL HG TYPE

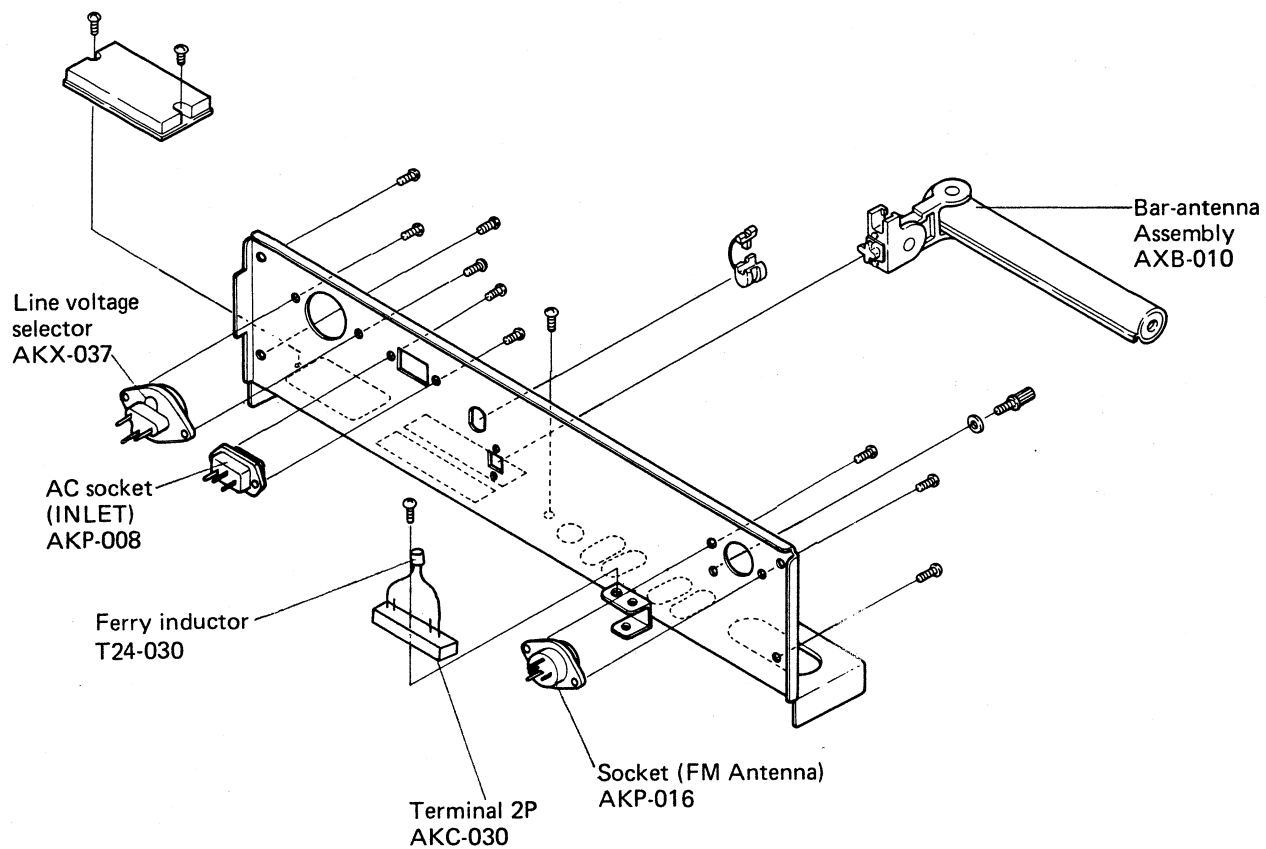

SCHEMATIC DIAGRAMS, P.C. BOARD PATTERN AND PARTS LIST FOR SX-450/HG

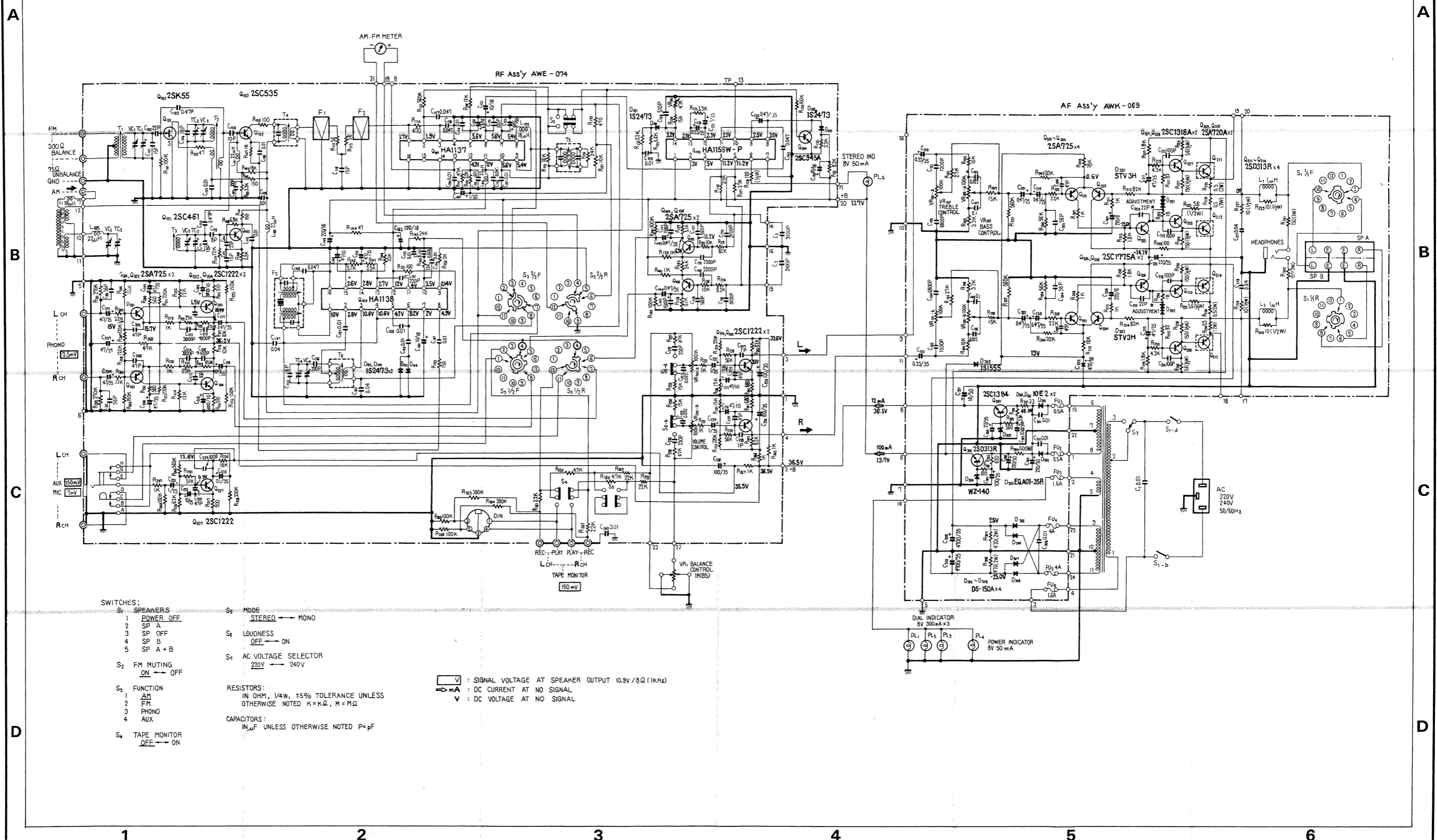

- SWITCHES:**
- S₁ SPEAKERS
 - 1 POWER OFF
 - 2 SP A
 - 3 SP OFF
 - 4 SP B
 - 5 SP A + B
 - S₂ FM MUTING
 - ON → OFF
 - S₃ FUNCTION
 - 1 AM
 - 2 FM
 - 3 PHONO
 - 4 AUX
 - S₄ TAPE MONITOR
 - OFF → ON
 - S₅ MODE
 - STEREO → MONO
 - S₆ LOUDNESS
 - OFF → ON
 - S₇ AC VOLTAGE SELECTOR
 - 220V → 240V
- RESISTORS:**
 IN OHM, 1/4W, ±5% TOLERANCE UNLESS OTHERWISE NOTED K=KΩ, M=MΩ
- CAPACITORS:**
 IN μF UNLESS OTHERWISE NOTED P=pF
- Legend:**
 V : SIGNAL VOLTAGE AT SPEAKER OUTPUT 10.9V/8Ω (1kHz)
 mA : DC CURRENT AT NO SIGNAL
 V : DC VOLTAGE AT NO SIGNAL

SX-450/HG

AF Assembly (AWK-069)

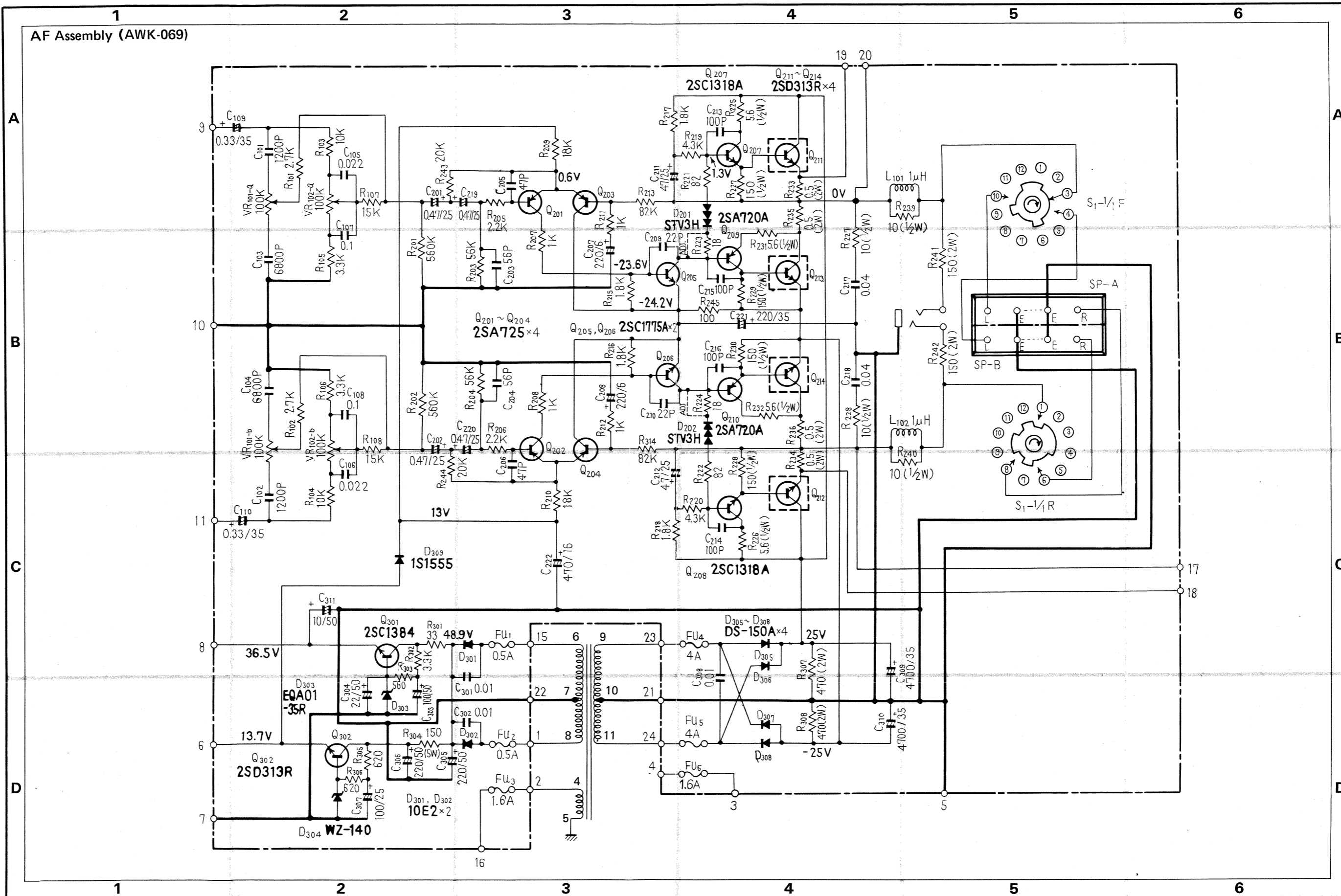

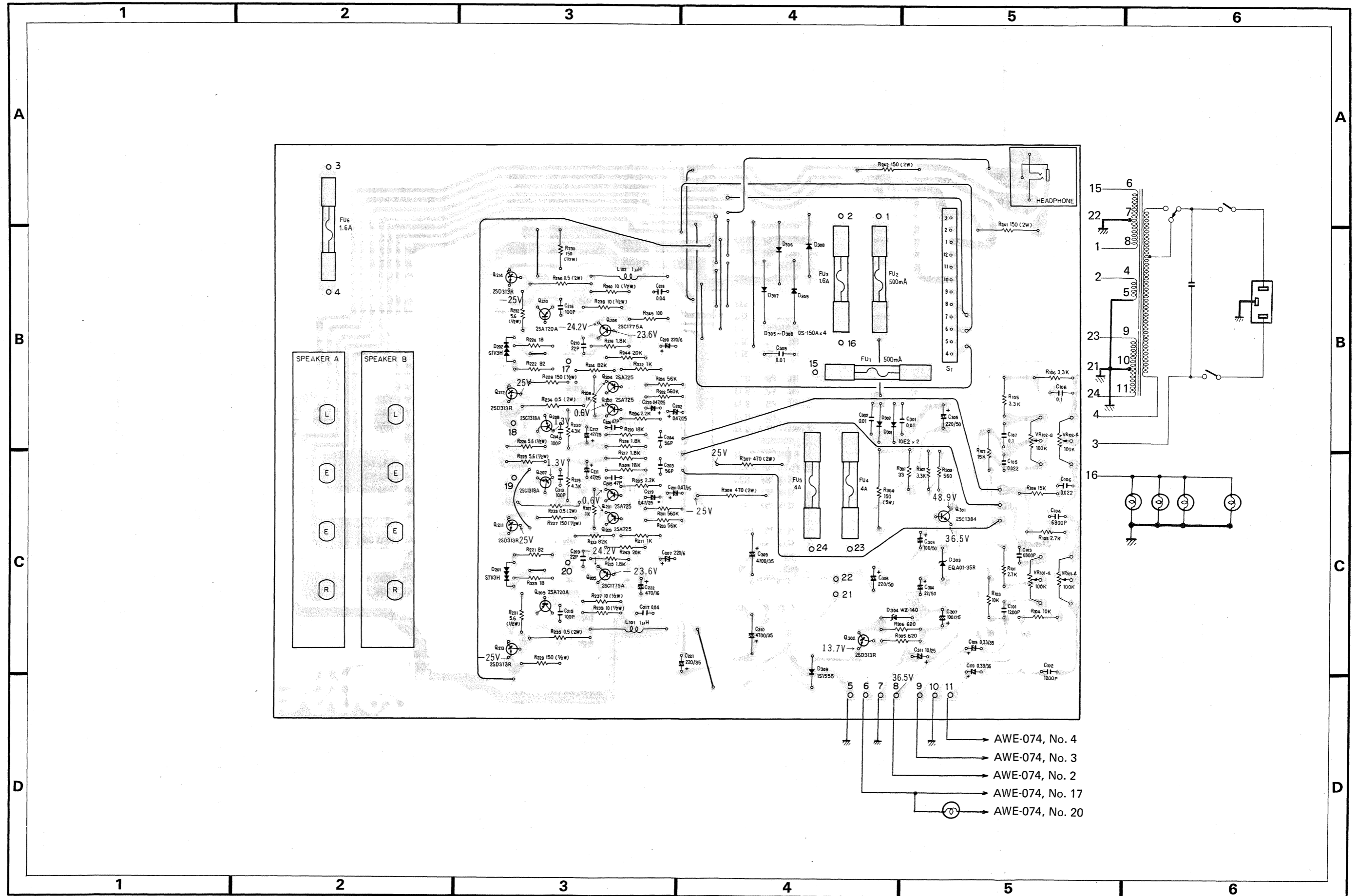

SX-450/HG

Parts List of AF Assembly (AWK-069)

SEMICONDUCTORS

Symbol	Description	Part No.
Q201	Transistor	2SA725-F (2SA640-F)
Q202	Transistor	2SA725-F (2SA640-F)
Q203	Transistor	2SA725-F (2SA640-F)
Q204	Transistor	2SA725-F (2SA640-F)
Q205	Transistor	2SC1775A-E
Q206	Transistor	2SC1775A-E
Q207	Transistor	2SC1318A-S (2SC1211-D)
Q208	Transistor	2SC1318A-S (2SC1211-D)
Q209	Transistor	2SA720A-S (2SA697-D)
Q210	Transistor	2SA720A-S (2SA697-D)
Q211	Transistor	2SD313R-D (2SD526-D)
Q212	Transistor	2SD313R-D (2SD526-D)
Q213	Transistor	2SD313R-D (2SD526-D)
Q214	Transistor	2SD313R-D (2SD526-D)
Q301	Transistor	2SC1384-O
Q302	Transistor	2SD313R-D (2SD526-D)
D201	Varistor	STV-3H
D202	Varistor	STV-3H
D301	Diode	10E2
D302	Diode	10E2
D303	Zener diode	EQA01-35R
D304	Zener diode	WZ-140
D305	Diode	DS-150A (30D2)
D306	Diode	DS-150A (30D2)
D307	Diode	DS-150A (30D2)
D308	Diode	DS-150A (30D2)
D309	Diode	1S1555 (1S2473)

SWITCH AND COILS

Symbol	Description	Part No.
	Rotary Switch (SPEAKERS)	ASA-045
L101	AF choke coil 1μH	ATH-011
L102	AF choke coil 1μH	ATH-011

RESISTORS

Symbol	Description	Part No.
VR101	Variable 100kΩ-A dual (TREBLE)	ACV-180
VR102	Variable 100kΩ-A dual (BASS)	ACV-180
R101	Carbon film 2.7k	RD½PSF 272J
R102	Carbon film 2.7k	RD½PSF 272J
R103	Carbon film 10k	RD½PSF 103J
R104	Carbon film 10k	RD½PSF 103J
R105	Carbon film 3.3k	RD½PSF 332J
R106	Carbon film 3.3k	RD½PSF 332J
R107	Carbon film 15k	RD½PSF 153J
R108	Carbon film 15k	RD½PSF 153J
R201	Carbon film 560k	RD½PSF 564J
R202	Carbon film 560k	RD½PSF 564J
R203	Carbon film 56k	RD½PSF 563J
R204	Carbon film 56k	RD½PSF 563J
R205	Carbon film 2.2k	RD½PSF 222J
R206	Carbon film 2.2k	RD½PSF 222J
R207	Carbon film 1k	RD½PSF 102J
R208	Carbon film 1k	RD½PSF 102J
R209	Carbon film 18k	RD½PSF 183J
R210	Carbon film 18k	RD½PSF 183J
R211	Carbon film 1k	RD½PSF 102J
R212	Carbon film 1k	RD½PSF 102J
R213	Carbon film 82k	RD½PSF 823J
R214	Carbon film 82k	RD½PSF 823J
R215	Carbon film 1.8k	RD½PSF 182J
R216	Carbon film 1.8k	RD½PSF 182J
R217	Carbon film 1.8k	RD½PSF 182J
R218	Carbon film 1.8k	RD½PSF 182J
R219	Carbon film 4.3k	RD½PSF 432J
R220	Carbon film 4.3k	RD½PSF 432J
R221	Carbon film 82	RD½PSF 820J
R222	Carbon film 82	RD½PSF 820J
R223	Carbon film 18	RD½PSF 180J
R224	Carbon film 18	RD½PSF 180J
R225	Carbon film 5.6 ½W	RD½PSF 5R6J
R226	Carbon film 5.6 ½W	RD½PSF 5R6J
R227	Carbon film 150 ½W	RD½PSF 151J
R228	Carbon film 150 ½W	RD½PSF 151J
R229	Carbon film 150 ½W	RD½PSF 151J
R230	Carbon film 150 ½W	RD½PSF 151J
R231	Carbon film 5.6 ½W	RD½PSF 5R6J
R232	Carbon film 5.6 ½W	RD½PSF 5R6J
R233	Metal film 0.5 2W	RN2H 0R5K
R234	Metal film 0.5 2W	RN2H 0R5K
R235	Metal film 0.5 2W	RN2H 0R5K
R236	Metal film 0.5 2W	RN2H 0R5K
R237	Carbon film 10 ½W	RD½PSF 100J
R238	Carbon film 10 ½W	RD½PSF 100J
R239	Carbon film 10 ½W	RD½PSF 100J
R240	Carbon film 10 ½W	RD½PSF 100J

Symbol	Description	Part No.
R241	Metal oxide film 150 2W	RS2P 151J
R242	Metal oxide film 150 2W	RS2P 151J
R243	Carbon film 20k	RD½PSF 203J
R244	Carbon film 20k	RD½PSF 203J
R245	Carbon film 100	RD½PSF 101J
R301	Carbon film 33	RD½PSF 330J
R302	Carbon film 3.3k	RD½PSF 332J
R303	Carbon film 560	RD½PSF 561J
R304	Wire wound 150 5W	RT5B 151K
R305	Carbon film 620	RD½PSF 621J
R306	Carbon film 620	RD½PSF 621J
R307	Metal oxide film 470 2W	RS2P 471J
R308	Metal oxide film 470 2W	RS2P 471J

CAPACITORS

Symbol	Description	Part No.
C101	Ceramic 1200p 50V	CKDYA 122J 50
C102	Ceramic 1200p 50V	CKDYA 122J 50
C103	Ceramic 6800p 50V	CKDYA 682J 50
C104	Ceramic 6800p 50V	CKDYA 682J 50
C105	Mylar 0.022 50V	CQMA 223J 50
C106	Mylar 0.022 50V	CQMA 223J 50
C107	Mylar 0.1 50V	CQMA 104J 50
C108	Mylar 0.1 50V	CQMA 104J 50
C109	Electrolytic 0.33 35V	CSZA R33M 35
C110	Electrolytic 0.33 35V	CSZA R33M 35
C201	Electrolytic 0.47 35V	CSZA R47M 35
C202	Electrolytic 0.47 35V	CSZA R47M 35
C203	Ceramic 56p 50V	CCDSL 560K 50
C204	Ceramic 56p 50V	CCDSL 560K 50
C205	Ceramic 47p 50V	CCDSL 470K 50
C206	Ceramic 47p 50V	CCDSL 470K 50
C207	Electrolytic 220 6V	CEA 221P 6
C208	Electrolytic 220 6V	CEA 221P 6
C209	Ceramic 22p 50V	CCDSL 220K 50
C210	Ceramic 22p 50V	CCDSL 220K 50
C211	Electrolytic 47 25V	CEA 470P 25
C212	Electrolytic 47 25V	CEA 470P 25
C213	Ceramic 100p 50V	CCDSL 101P 50
C214	Ceramic 100p 50V	CCDSL 101P 50
C215	Ceramic 100p 50V	CCDSL 101P 50
C216	Ceramic 100p 50V	CCDSL 101P 50
C217	Ceramic 0.04 50V	CKDYF 403Z 50
C218	Ceramic 0.04 50V	CKDYF 403Z 50
C219	Electrolytic 0.47 35V	CSZA R47M 35
C220	Electrolytic 0.47 35V	CSZA R47M 35

Symbol	Description	Part No.
C221	Electrolytic 220 35V	CEA 221P 50
C222	Electrolytic 470 16V	CEA 471P 16
C301	Ceramic 0.01 150V	ACG-004
C302	Ceramic 0.01 150V	ACG-004
C303	Electrolytic 100 50V	CEA 101P 50
C304	Electrolytic 22 50V	CEA 220P 50
C305	Electrolytic 220 50V	CEA 221P 50
C306	Electrolytic 220 50V	CEA 221P 50
C307	Electrolytic 100 25V	CEA 101P 25
C308	Ceramic 0.01 150V	ACG-004
C309	Electrolytic 4700 35V	ACH-043
C310	Electrolytic 4700 35V	ACH-043
C311	Electrolytic 10 50V	CEA 100P 50

OTHERS

Symbol	Description	Part No.
	Heat sink (small)	ANH-117
	Terminal (SPEAKERS)	AKE-029
	Phone jack	AKN-009
	Fuse clip	AKR-010

1 2 3 4 5 6
SCHEMATIC DIAGRAM, P.C. BOARD PATTERN AND PARTS LIST FOR SX-450/S

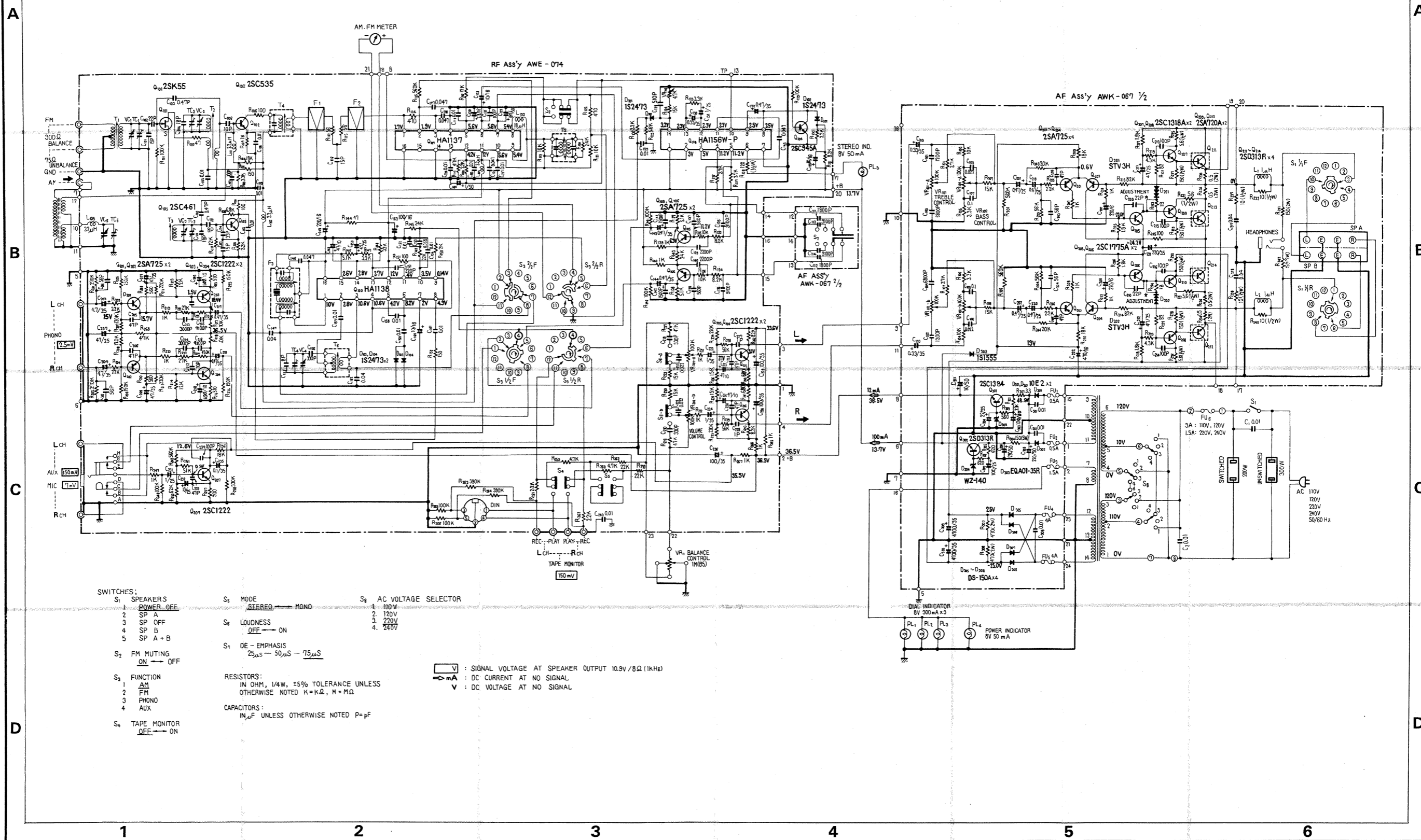

- SWITCHES:**
- S₁ SPEAKER POWER OFF
 - 1 SP A
 - 2 SP OFF
 - 3 SP B
 - 4 SP A + B
 - S₂ FM MUTING ON → OFF
 - S₃ FUNCTION 1 AM, 2 FM, 3 PHONO, 4 AUX
 - S₄ TAPE MONITOR OFF → ON
 - S₅ MODE STEREO → MONO
 - S₆ LOUDNESS DEF → ON
 - S₇ DE-EMPHASIS 25μs → 50μs → 75μs
 - S₈ AC VOLTAGE SELECTOR 1 110V, 2 120V, 3 220V, 4 240V
- RESISTORS:**
 IN OHM, 1/4W, ±5% TOLERANCE UNLESS OTHERWISE NOTED K=KΩ, M=MΩ
- CAPACITORS:**
 IN μF UNLESS OTHERWISE NOTED P=pF

⊖ : SIGNAL VOLTAGE AT SPEAKER OUTPUT 10.9V / 8Ω (1KHz)
 ⊖ mA : DC CURRENT AT NO SIGNAL
 ⊖ V : DC VOLTAGE AT NO SIGNAL

SX-450/S

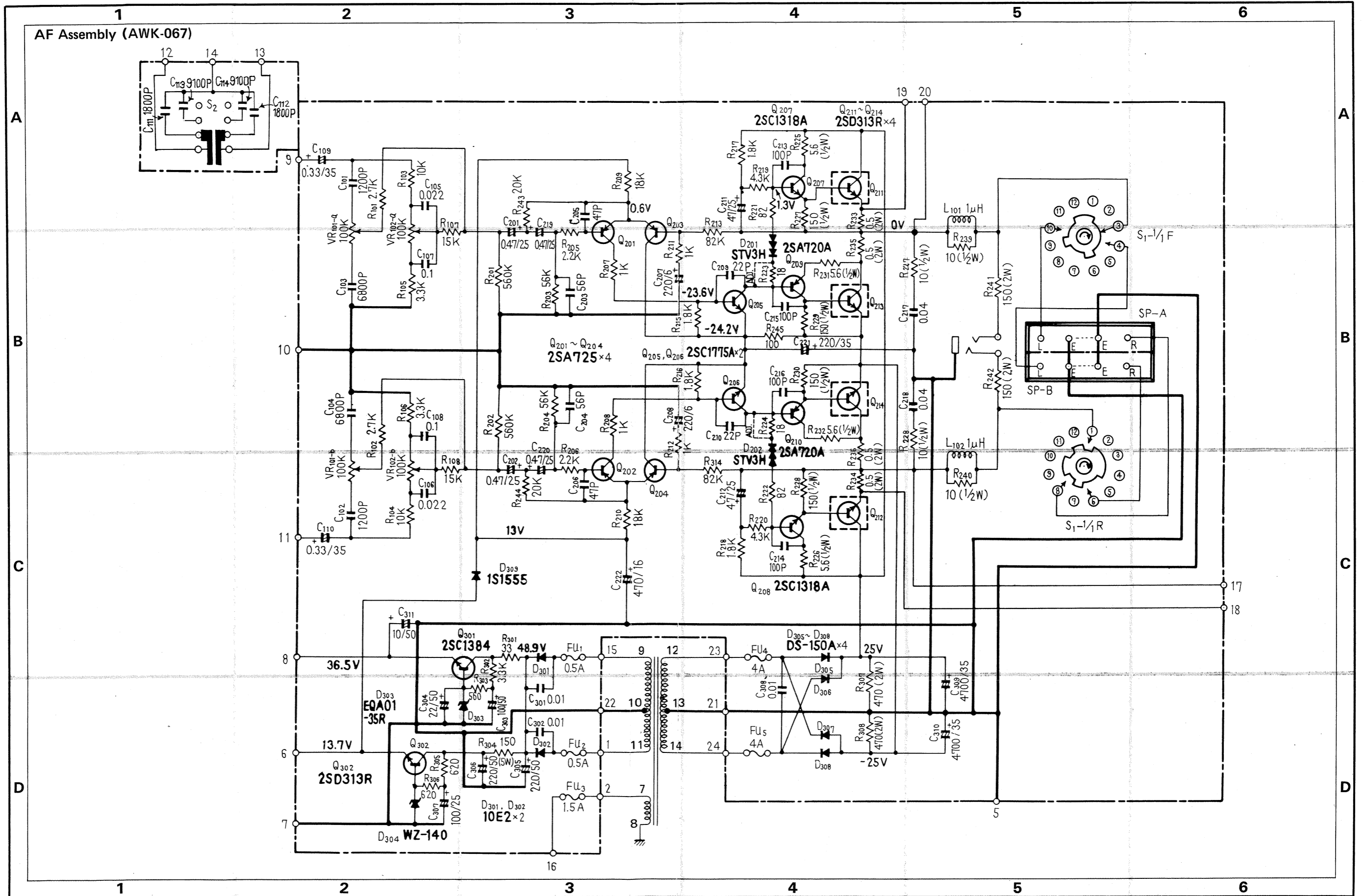

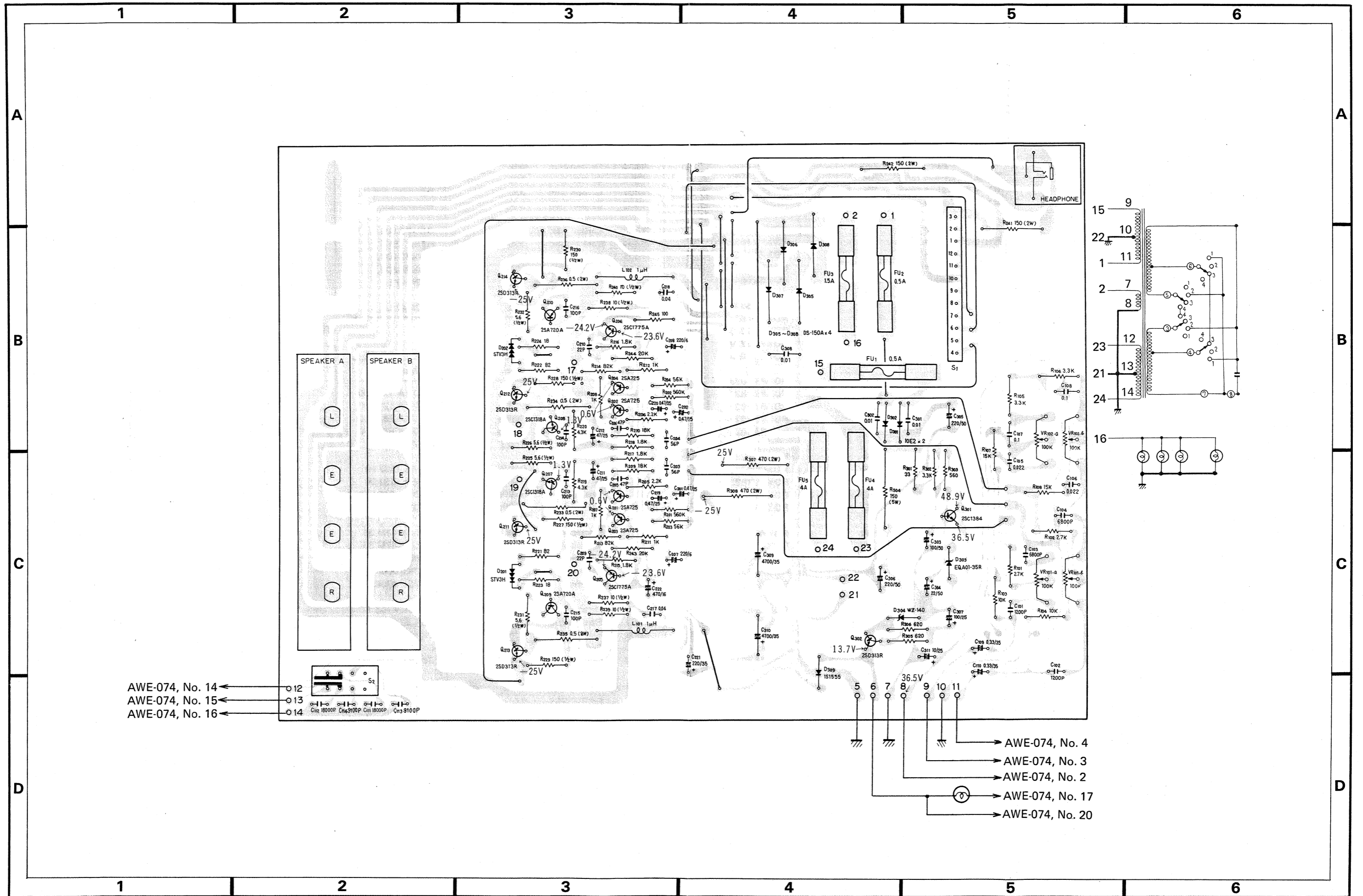

AWE-074, No. 14 ← ○ 12
 AWE-074, No. 15 ← ○ 13
 AWE-074, No. 16 ← ○ 14

→ AWE-074, No. 4
 → AWE-074, No. 3
 → AWE-074, No. 2
 → AWE-074, No. 17
 → AWE-074, No. 20

SX-450/S

AF Ass'y AWK-067

SEMICONDUCTORS

Symbol	Description	Part No.
Q201	Transistor	2SA725-F (2SA640-F)
Q202	Transistor	2SA725-F (2SA640-F)
Q203	Transistor	2SA725-F (2SA640-F)
Q204	Transistor	2SA725-F (2SA640-F)
Q205	Transistor	2SC1775A-E
Q206	Transistor	2SC1775A-E
Q207	Transistor	2SC1318A-S (2SC1211-D)
Q208	Transistor	2SC1318A-S (2SC1211-D)
Q209	Transistor	2SA720A-S (2SA697-D)
Q210	Transistor	2SA720A-S (2SA697-D)
Q211	Transistor	2SD313R-D (2SD526-D)
Q212	Transistor	2SD313R-D (2SD526-D)
Q213	Transistor	2SD313R-D (2SD526-D)
Q214	Transistor	2SD313R-D (2SD526-D)
Q301	Transistor	2SC1384-Q
Q302	Transistor	2SD313R-D (2SD526-D)
D201	Varistor	STV-3H
D202	Varistor	STV-3H
D301	Diode	10E2
D302	Diode	10E2
D303	Zener diode	EQA01-35R
D304	Zener diode	WZ-140
D305	Diode	DS-150A (30D2)
D306	Diode	DS-150A (30D2)
D307	Diode	DS-150A (30D2)
D308	Diode	DS-150A (30D2)
D309	Diode	1S1555 (1S2473)

SWITCHES AND COILS

Symbol	Description	Part No.
	Rotary switch (SPEAKERS)	ASA-044
	Slide Switch (DE-EMPHASIS)	ASH-017
L101	AF choke coil 1μH	ATH-011
L102	AF choke coil 1μH	ATH-011

RESISTORS

Symbol	Description	Part No.
VR101	Variable 100kΩ-A dual (TREBLE)	ACV-180
VR102	Variable 100kΩ-A dual (BASS)	ACV-180
R101	Carbon film 2.7k	RD¼PS 272J
R102	Carbon film 2.7k	RD¼PS 272J
R103	Carbon film 10k	RD¼PS 103J
R104	Carbon film 10k	RD¼PS 103J
R105	Carbon film 3.3k	RD¼PS 332J
R106	Carbon film 3.3k	RD¼PS 332J
R107	Carbon film 15k	RD¼PS 153J
R108	Carbon film 15k	RD¼PS 153J
R201	Carbon film 560k	RD¼PS 564J
R202	Carbon film 560k	RD¼PS 564J
R203	Carbon film 56k	RD¼PS 563J
R204	Carbon film 56k	RD¼PS 563J
R205	Carbon film 2.2k	RD¼PS 222J
R206	Carbon film 2.2k	RD¼PS 222J
R207	Carbon film 1k	RD¼PS 102J
R208	Carbon film 1k	RD¼PS 102J
R209	Carbon film 18k	RD¼PS 183J
R210	Carbon film 18k	RD¼PS 183J
R211	Carbon film 1k	RD¼PS 102J
R212	Carbon film 1k	RD¼PS 102J
R213	Carbon film 82k	RD¼PS 823J
R214	Carbon film 82k	RD¼PS 823J
R215	Carbon film 1.8k	RD¼PS 182J
R216	Carbon film 1.8k	RD¼PS 182J
R217	Carbon film 1.8k	RD¼PS 182J
R218	Carbon film 1.8k	RD¼PS 182J
R219	Carbon film 4.3k	RD¼PS 432J
R220	Carbon film 4.3k	RD¼PS 432J
R221	Carbon film 82	RD¼PS 820J
R222	Carbon film 82	RD¼PS 820J
R223	Carbon film 18	RD¼PS 180J
R224	Carbon film 18	RD¼PS 180J
R225	Carbon film 5.6 ¼W	RD¼PS 5R6J
R226	Carbon film 5.6 ¼W	RD¼PS 5R6J
R227	Carbon film 150 ¼W	RD¼PS 151J
R228	Carbon film 150 ¼W	RD¼PS 151J
R229	Carbon film 150 ¼W	RD¼PS 151J
R230	Carbon film 150 ¼W	RD¼PS 151J
R231	Carbon film 5.6 ¼W	RD¼PS 5R6J
R232	Carbon film 5.6 ¼W	RD¼PS 5R6J
R233	Metal film 0.5 2W	RN2H 0R5K
R234	Metal film 0.5 2W	RN2H 0R5K
R235	Metal film 0.5 2W	RN2H 0R5K
R236	Metal film 0.5 2W	RN2H 0R5K
R237	Carbon film 10 ¼W	RD¼PS 100J
R238	Carbon film 10 ¼W	RD¼PS 100J
R239	Carbon film 10 ¼W	RD¼PS 100J
R240	Carbon film 10 ¼W	RD¼PS 100J

Symbol	Description	Part No.
R241	Metal oxide film 150 2W	RS2P 151J
R242	Metal oxide film 150 2W	-RS2P 151J
R243	Carbon film 20k	RD¼PS 203J
R244	Carbon film 20k	RD¼PS 203J
R245	Carbon film 100	RD¼PS 101J
R301	Carbon film 33	RD¼PSF 330J
R302	Carbon film 3.3k	RD¼PS 332J
R303	Carbon film 560	RD¼PS 561J
R304	Wire wound 150 5W	RT5B 151K
R305	Carbon film 620	RD¼PS 621J
R306	Carbon film 620	RD¼PS 621J
R307	Metal oxide film 470 2W	RS2P 471J
R308	Metal oxide film 470 2W	RS2P 471J

CAPACITORS

Symbol	Description	Part No.
C101	Ceramic 1200p 50V	CKDYA 122J 50
C102	Ceramic 1200p 50V	CKDYA 122J 50
C103	Ceramic 6800p 50V	CKDYA 682J 50
C104	Ceramic 6800p 50V	CKDYA 682J 50
C105	Mylar 0.022 50V	CQMA 223J 50
C111	Mylar 0.018 50V	CQMA 183J 50
C112	Mylar 0.018 50V	CQMA 183J 50
C113	Ceramic 9100p 50V	CKDYA 912J 50
C114	Ceramic 9100p 50V	CKDYA 912J 50
C201	Electrolytic 0.47 35V	CSZA R47M 35
C202	Electrolytic 0.47 35V	CSZA R47M 35
C203	Ceramic 56p 50V	CCDSL 560K 50
C204	Ceramic 56p 50V	CCDKS 560K 50
C205	Ceramic 47p 50V	CCDSL 470K 50
C206	Ceramic 47p 50V	CCDSL 470K 50
C207	Electrolytic 220 6V	CEA 221P 6
C208	Electrolytic 220 6V	CEA 221P 6
C209	Ceramic 22p 50V	CCDSL 220K 50
C210	Ceramic 22p 50V	CCDSL 220K 50
C211	Electrolytic 47 25V	CEA 470P 25
C212	Electrolytic 47 25V	CEA 470P 25
C213	Ceramic 100p 50V	CCDSL 101P 50
C214	Ceramic 100p 50V	CCDSL 101P 50
C215	Ceramic 100p 50V	CCDSL 101P 50
C216	Ceramic 100p 50V	CCDSL 101P 50
C217	Ceramic 0.04 50V	CKDYF 403Z 50
C218	Ceramic 0.04 50V	CKDYF 403Z 50
C219	Electrolytic 0.47 35V	CSZA R47M 35
C220	Electrolytic 0.47 35V	CSZA R47M 35

Symbol	Description	Part No.
C221	Electrolytic 220 35V	CEA 221P 50
C222	Electrolytic 470 16V	CEA 471P 16
C301	Ceramic 0.01 150V	ACG-004
C302	Ceramic 0.01 150V	ACG-004
C303	Electrolytic 100 50V	CEA 101P 50
C304	Electrolytic 22 50V	CEA 220P 50
C305	Electrolytic 220 50V	CEA 221P 50
C306	Electrolytic 220 50V	CEA 221P 50
C307	Electrolytic 100 25V	CEA 101P 25
C308	Ceramic 0.01 150V	ACG-004
C309	Electrolytic 4700 35V	ACH-043
C310	Electrolytic 4700 35V	ACH-043
C311	Electrolytic 10 50V	CEA 100P 50

OTHERS

Symbol	Description	Part No.
	Heat sink (small)	ANH-117
	Terminal (SPEAKERS)	AKE-029
	Phone jack	AKN-009
	Fuse clip	AKR-013

AM/FM STEREO RECEIVER

SX-450 HG

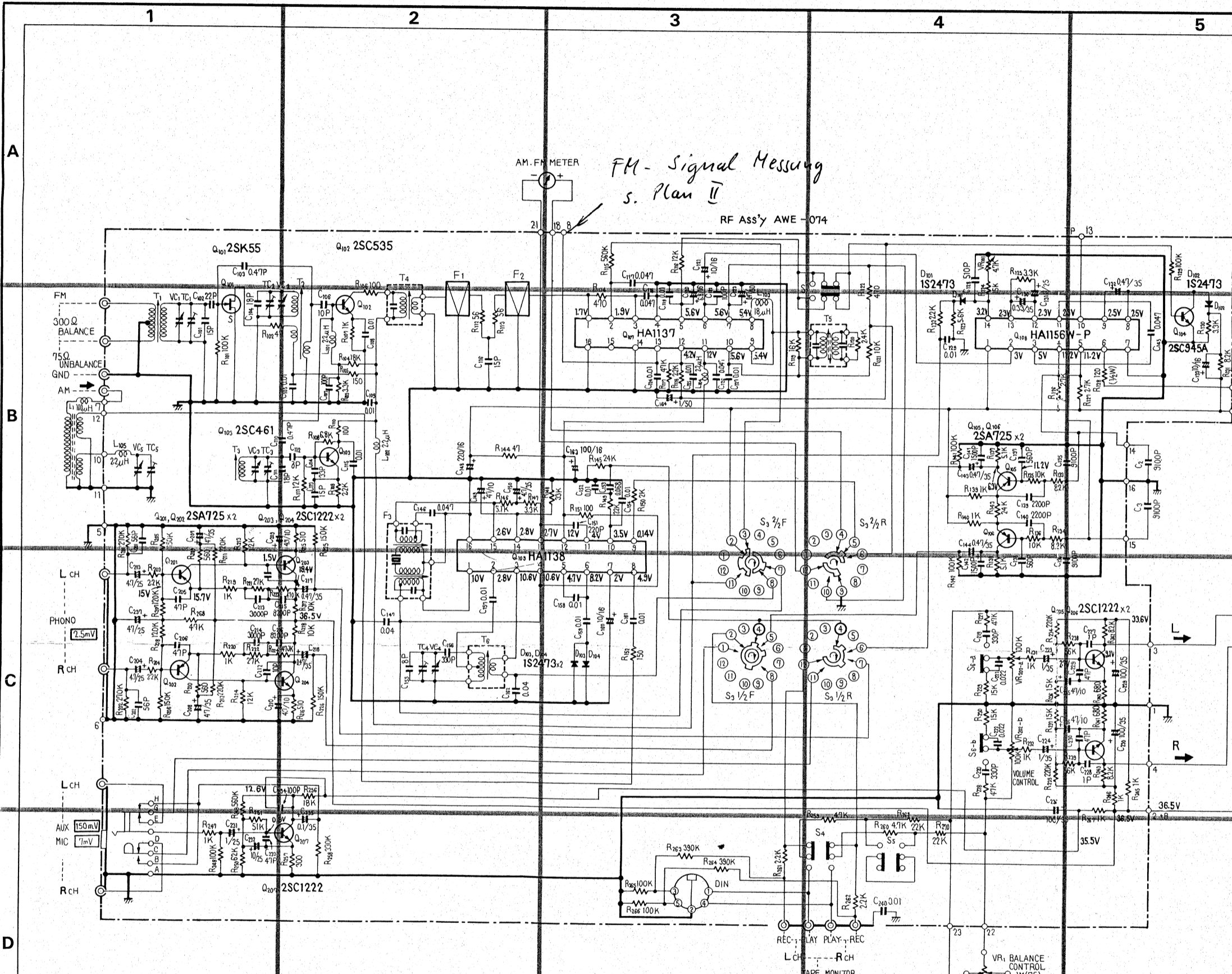

AM-FM METER
 FM-Signal Messung
 s. Plan II

RF Ass'y AWE-074

- SWITCHES:
- S₁ SPEAKERS
 1 POWER OFF
 2 SP A
 3 SP OFF
 4 SP B
 5 SP A + B
 - S₂ FM MUTING
 ON → OFF
 - S₃ FUNCTION
 1 AM
 2 FM
 3 PHONO
 4 AUX
 - S₄ TAPE MONITOR
 OFF → ON
 - S₅ MODE
 STEREO ↔ MONO
 - S₆ LOUDNESS
 OFF → ON
 - S₇ AC VOLTAGE SELECTOR
 220V → 240V

RESISTORS:
 IN OHM, 1/4W, ±5% TOLERANCE UNLESS
 OTHERWISE NOTED K=KΩ, M=MΩ

CAPACITORS:
 IN μF UNLESS OTHERWISE NOTED P=pF

⊖ : SIGNAL VOLTAGE AT SPEAKER OUTPUT 10.9V/8Ω (1kHz)
 → mA : DC CURRENT AT NO SIGNAL
 ∇ : DC VOLTAGE AT NO SIGNAL

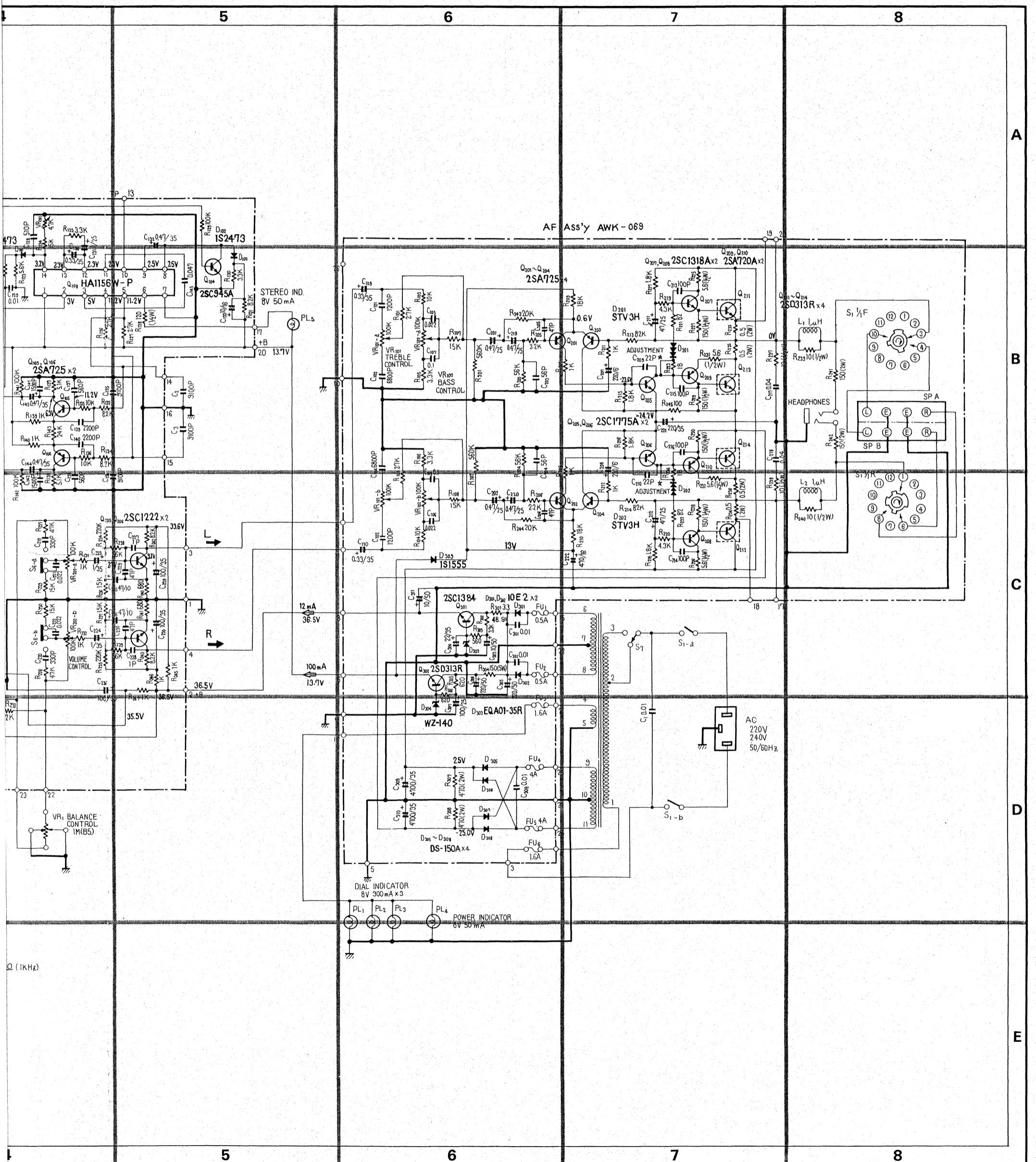

Ω (1KHz)

AM/FM STEREO RECEIVER

SX-450 S

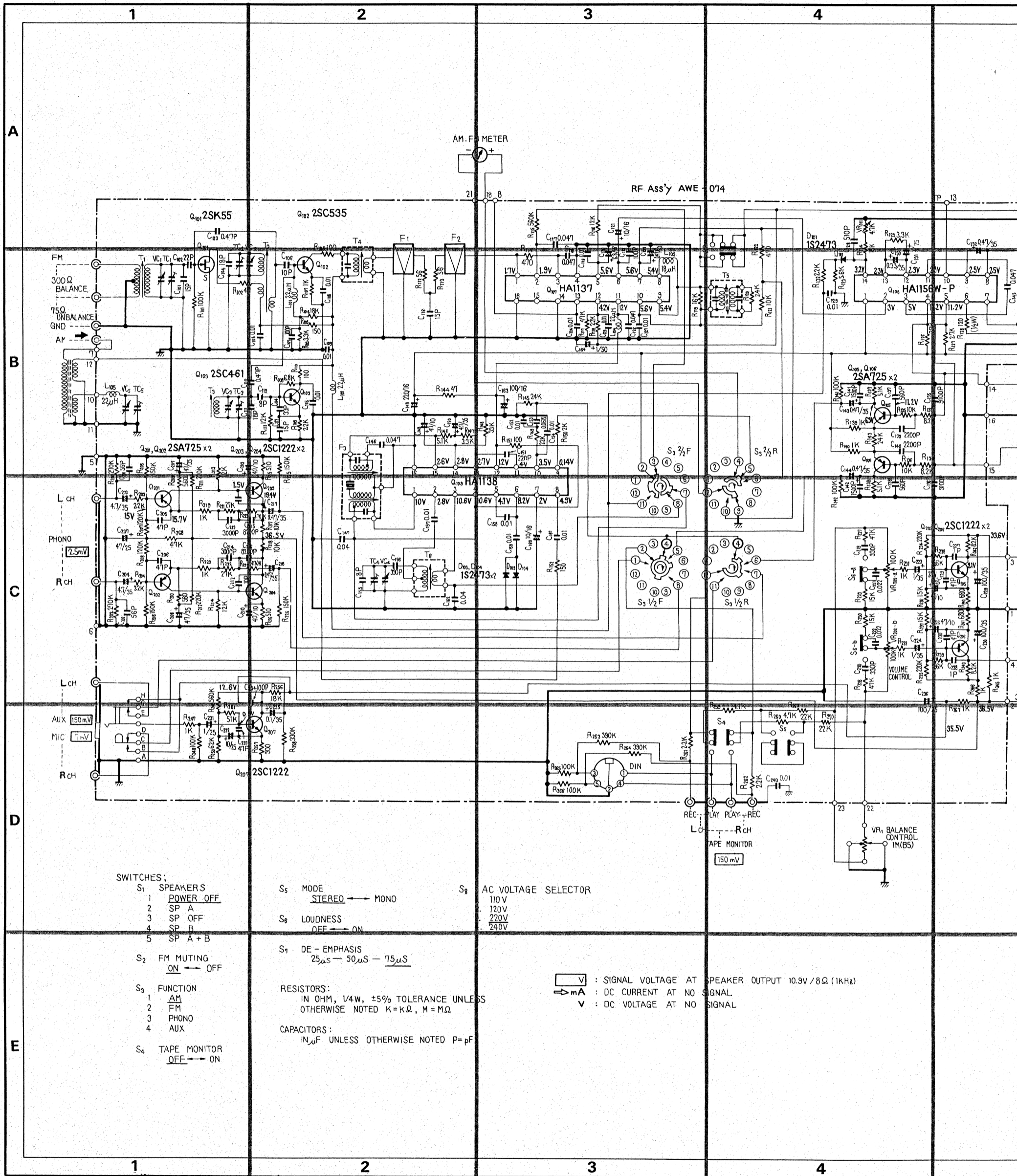

SWITCHES:

- | | | | | | | | |
|--|--------------------------------------|---|---|--------------------------------------|-------------------------------------|--|--|
| S ₁ SPEAKERS
1 POWER OFF
2 SP A
3 SP OFF
4 SP B
5 SP A + B | S ₂ FM MUTING
ON → OFF | S ₃ FUNCTION
1 AM
2 FM
3 PHONO
4 AUX | S ₄ TAPE MONITOR
OFF → ON | S ₅ MODE
STEREO → MONO | S ₆ LOUDNESS
OFF → ON | S ₇ DE-EMPHASIS
25μs — 50μs — 75μs | S ₈ AC VOLTAGE SELECTOR
110V
120V
220V
240V |
|--|--------------------------------------|---|---|--------------------------------------|-------------------------------------|--|--|

RESISTORS:
IN OHM, 1/4W, ±5% TOLERANCE UNLESS OTHERWISE NOTED K=KΩ, M=MΩ

CAPACITORS:
IN μF UNLESS OTHERWISE NOTED P=pF

: SIGNAL VOLTAGE AT SPEAKER OUTPUT 10.9V / 8Ω (1KHz)
 : DC CURRENT AT NO SIGNAL
 : DC VOLTAGE AT NO SIGNAL

5

6

7

8

A

B

C

D

E

AF Ass'y AWK-067 1/2

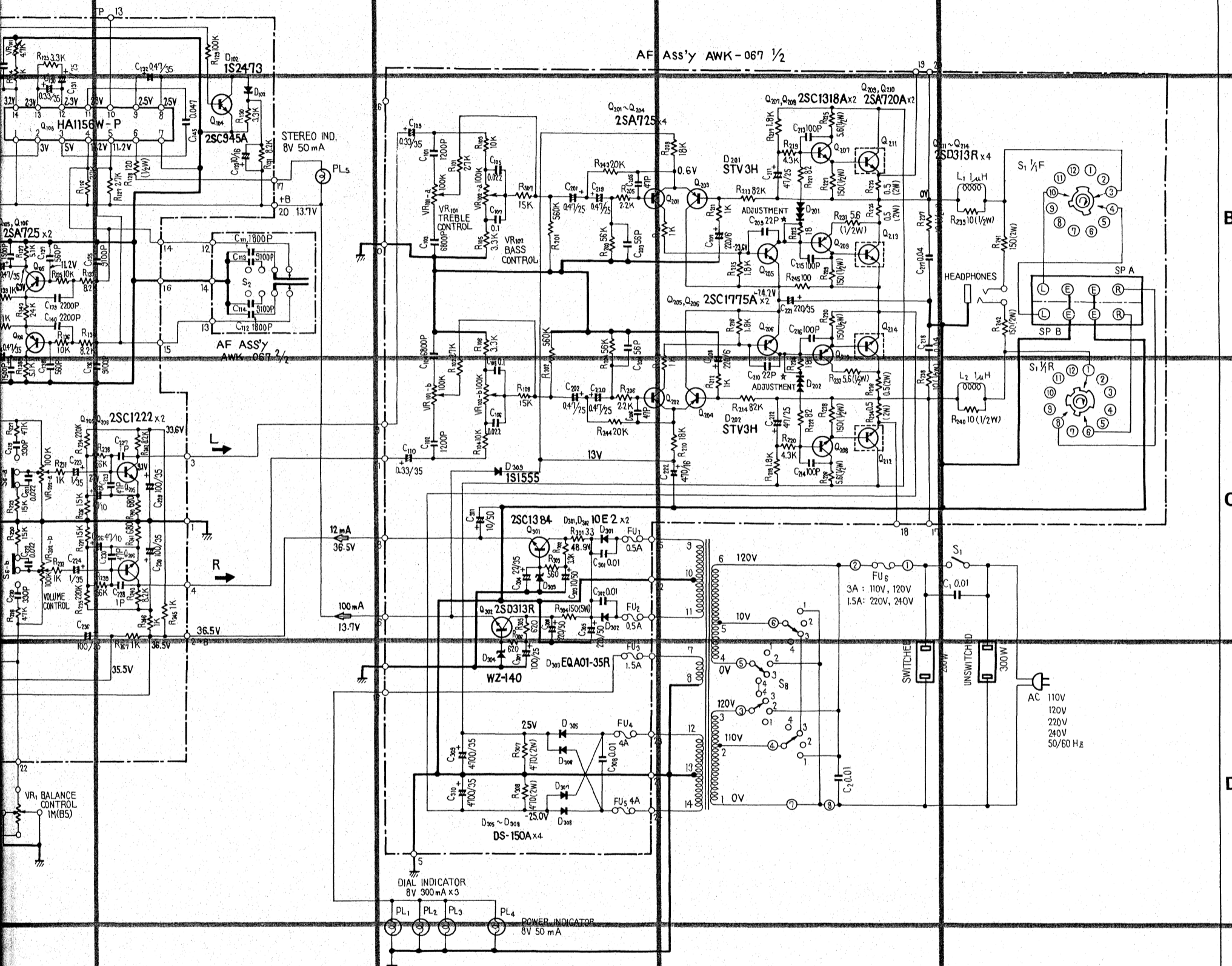

AM/FM STEREO RECEIVER

SX-450

KU
KC

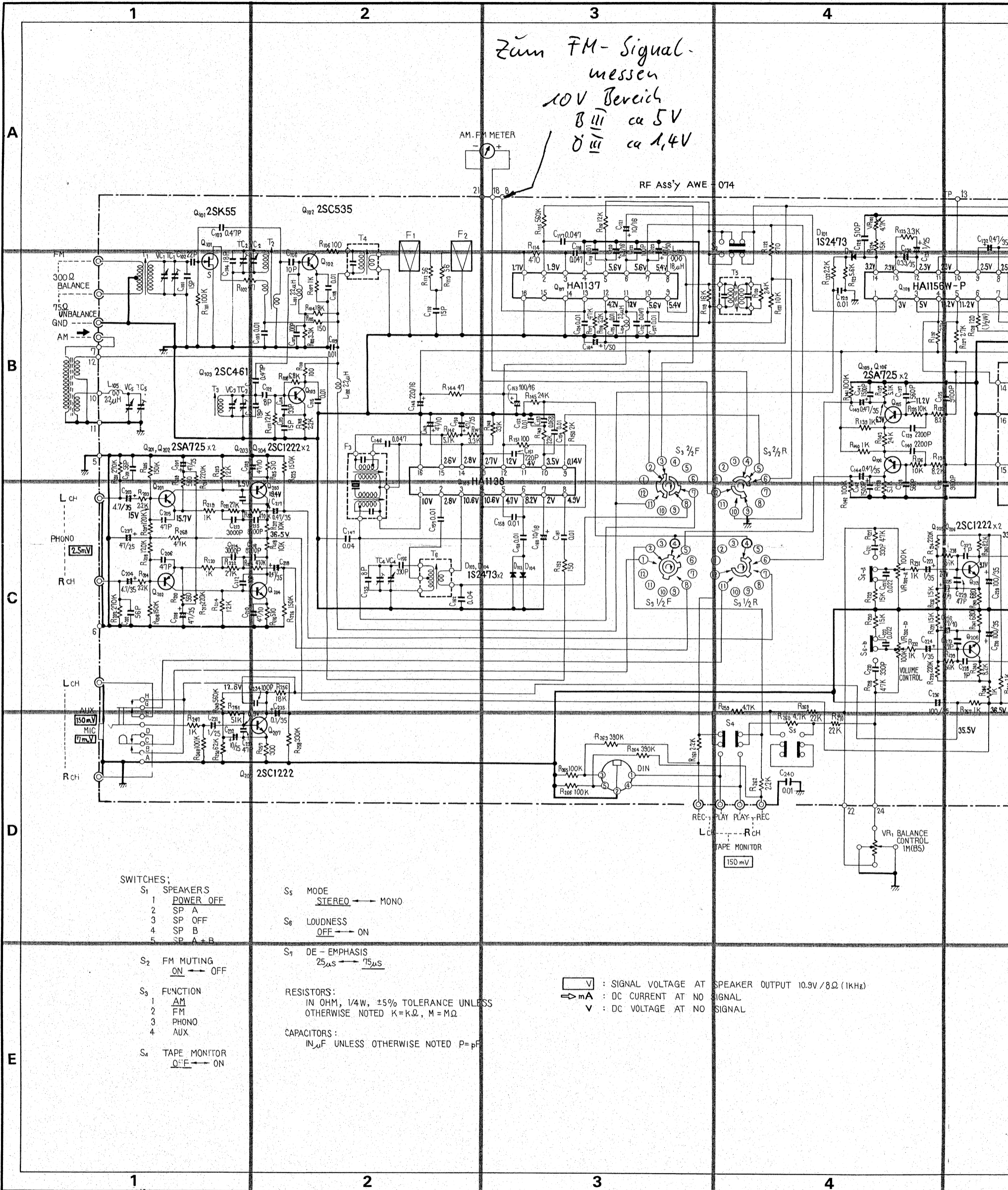

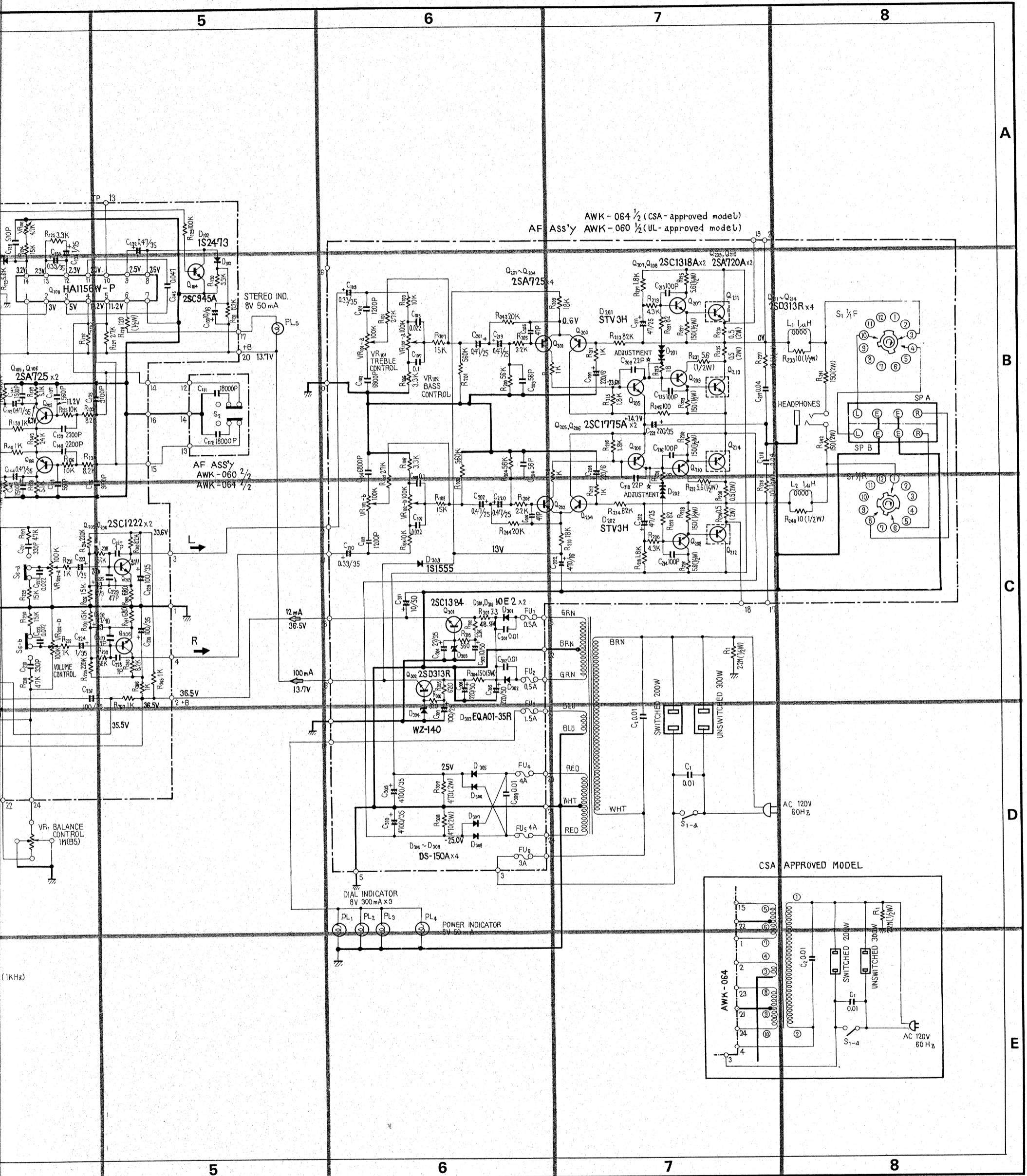

(1KHz)