

AM-FM STEREO RECEIVER

# KR-4070

INSTRUCTION MANUAL



*the sound approach to quality*  
**KENWOOD**

## INTRODUCTION

The purpose of this manual is to acquaint you with the operating features of your new receiver. You will notice that in every detail of planning, engineering, styling, operating convenience, and adaptability, we have sought to anticipate your needs and desires.

We suggest that you read this manual carefully. Knowing how to set up your receiver, to the best advantage, will enhance your listening pleasure right from the start. You will also become aware of the ease with which you can adjust your receiver to meet your special requirements.

## SERIAL NUMBER

Record your SERIAL NUMBER on the spaces designated on the warranty card. You will find the serial number on the back of the unit.

## AFTER UNPACKING

After unpacking, we recommend you inspect and examine the unit for any possible shipping damage. If your unit is damaged or fails to operate, notify your dealer immediately. If your unit was shipped to you directly, notify the shipping company without delay. Only the consignee (the person or company receiving the unit) can file a claim against the carrier for shipping damage.

We recommend you retain the original carton and packing materials to prevent any damage should you transport or ship your unit in the future.

## PRECAUTIONS ON INSTALLATION

- Avoid locations subject to direct sunlight.
- Avoid high or low temperature extremes.
- Keep the unit away from heat radiating source and magnetism generating source.
- Choose locations with as little vibration and dust as possible.

**WARNING:**  
TO PREVENT FIRE OR SHOCK HAZARD, DO NOT EXPOSE THIS APPLIANCE TO RAIN OR MOISTURE.

## IMPORTANT!

- Units shipped to U.S.A. and Canada are designed to operate on 120 volts AC only and are not equipped with an AC Voltage Selector Switch. Therefore, the following description on such a switch should be disregarded.
- Units shipped to all other countries are equipped with an AC Voltage Selector Switch on the rear panel. The following description on this switch, "AC Voltage Selection", should be carefully read.

## AC VOLTAGE SELECTION

This unit operates on 120 volts, 220 volts or 240 volts AC. The AC Voltage Selector Switch is set to the voltage generally available in the country where the unit is shipped. It is important to make sure, before connecting the power cord to your AC outlet, whether the setting position of this switch corresponds to your voltage. If not, it must be changed to the proper setting in accordance with the direction below.

**NOTE:**  
Our warranty does not cover damage caused by excessive line voltage due to improper setting of the AC Voltage Selector Switch.

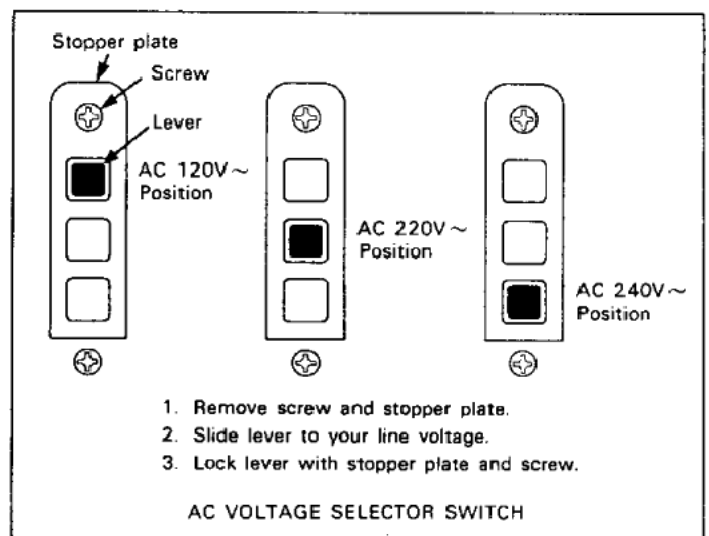

## CONTENTS

FEATURES .....	3
INTERCONNECTING DIAGRAM .....	4
CONTROLS AND THEIR FUNCTIONS .....	5
CONNECTING INSTRUCTIONS .....	6
OPERATING INSTRUCTIONS .....	10
POINTS TO BE CHECKED PRIOR TO SERVICING .....	12
SPECIFICATIONS .....	12

## FEATURES

1. Low noise cascade junction type FET and frequency linear type precision 3-ganged variable capacitor are employed in the FM front end. These are followed by high selective IF section and phase locked loop system IC in the MPX circuits. These highly reliable elements will give you stable FM reception.
2. AM section is equipped with high selectivity ceramic filter and high performance dual-in-line type IC. This will promise you optimum reception.
3. Employs large size of signal and tuning meters.
4. Employs large size of dial stroke of 10-5/8" (270 mm).
5. Equipped with convenient muting circuit which automatically silences interstation noise.
6. 40 watts per channel, minimum RMS at 8 ohms, from 20 Hz to 20 kHz with no more than 0.1% total harmonic distortion.
7. Power amplifier section employs differential amplifier with high stability and low distortion in first and second stages, and, direct coupled circuit, in all stages.
8. Adoption of the Kenwood ASO (area of safe operation) detection limiter system for the protection circuit which protects power transistor.
9. Pre-amplifier is equipped with operational IC amplifier of single-in-line type, and this will assure you low noise, low distortion and increase of dynamic range.
10. Devised to improve stability in power source and sound quality by employing two electrolytic capacitors of 7500 $\mu$ F.
11. Decreased wires thanks to a large-sized printed circuit board.
12. Two pairs of speakers can be used.
13. Equipped with a massive heat sink.

# INTERCONNECTING DIAGRAM

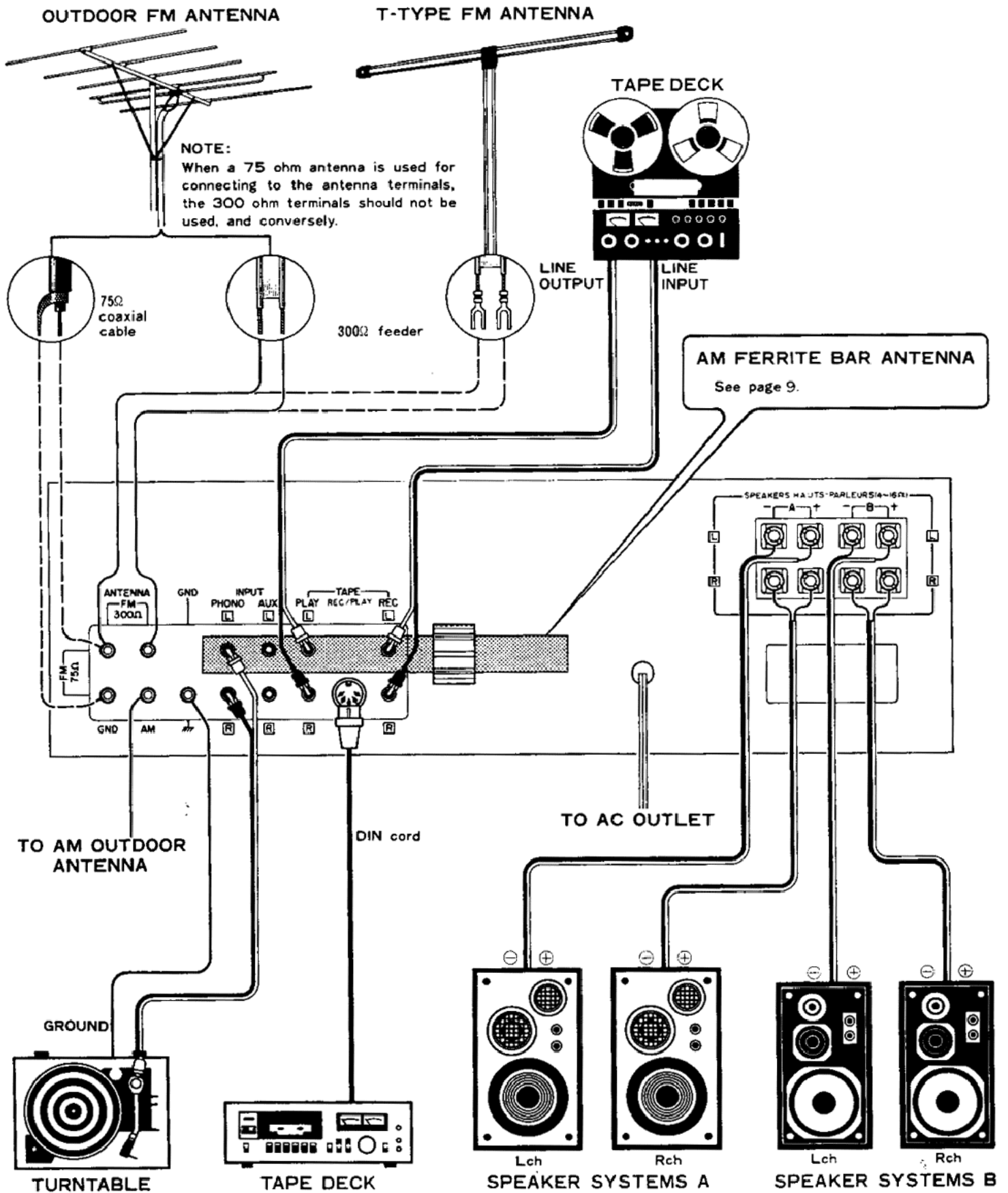

# CONTROLS AND THEIR FUNCTIONS

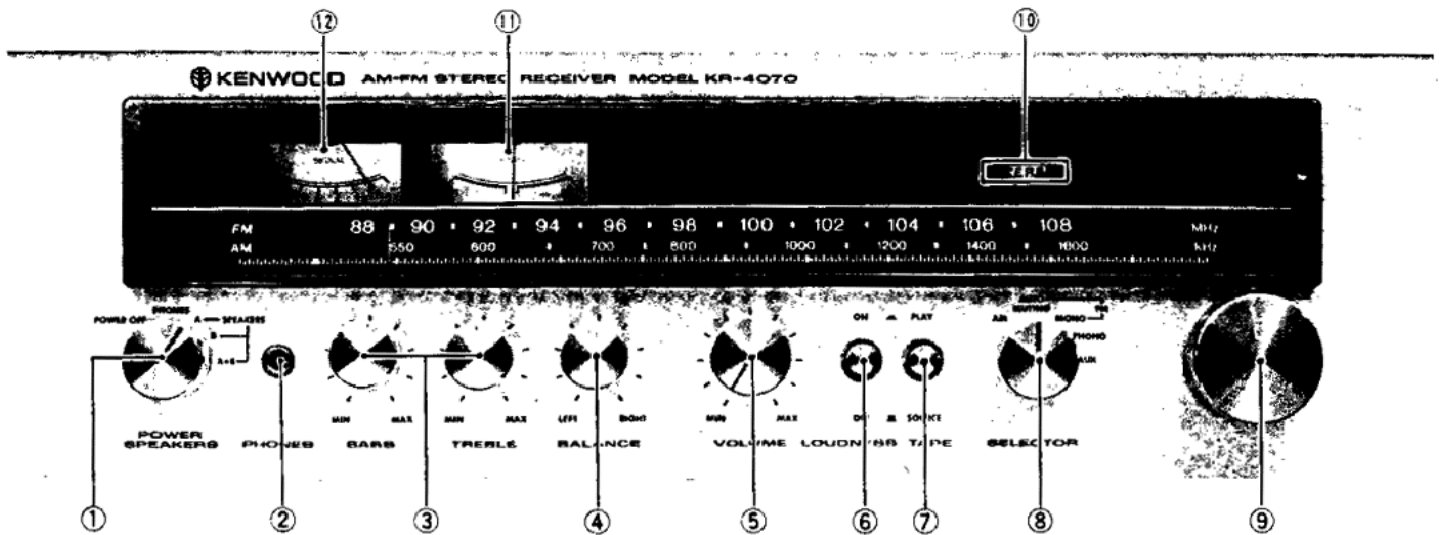

## ① POWER/PHONES/SPEAKERS switch

A combined switch for power, headphones and speaker selection.

**POWER OFF** ..... Receiver off.

**PHONES** ..... Speakers cut off (headphones can be used).

**A** ..... To listen to speakers connected to the SPEAKERS A terminals.

**B** ..... To listen to speakers connected to the SPEAKERS B terminals.

**A+B** ..... To listen simultaneously to speakers connected to the A and B SPEAKERS terminals.

## ② PHONES jack

Insert a stereo headphone plug into this jack for private listening. The speakers are silenced when the SPEAKERS switch is set to PHONES position.

## ③ BASS and TREBLE controls

**BASS control** ..... Turning it clockwise increases low frequencies and counterclockwise decreases it.

**TREBLE control**.... Turning it clockwise increases high frequencies and counterclockwise decreases it.

## ④ BALANCE control

This control adjusts unequal volume from any program source in right and left channels. The left channel is accentuated when this control is turned from center toward the left side, and conversely.

## ⑤ VOLUME control

This control adjusts simultaneously volumes in both channels (right and left). Set it to your own most satisfactory listening level.

## ⑥ LOUDNESS switch

This switch boosts bass and treble tones at low listening levels. Our ears have less sensitivity to low and high frequencies at low listening levels and this switch compensates for this deficiency. This switch should be off when listening at normal and high levels.

## ⑦ TAPE switch

Depress this switch when using a tape deck for tape playback, or when monitoring a tape during recording.

### NOTE:

Except for tape playback, make sure it is in the "SOURCE" position.

## ⑧ SELECTOR switch

Switch positions and functions are as follows:

**AM** ..... To receive AM broadcast.

**AUTO/MUTING** ... To receive both FM mono and stereo broadcasts. Automatic switching operates between FM mono and stereo broadcast. This position also silences the interstation noise on the FM band.

**MONO** ..... To receive FM mono broadcast.

**PHONO** ..... To operate a turntable connected to the PHONO jacks.

**AUX** ..... To select source connected to the AUX jacks.

## ⑨ TUNING knob

Select the desired AM or FM station while observing the SIGNAL and/or TUNING meters for optimum tuning.

## ⑩ FM STEREO indicator

With the SELECTOR switch set to AUTO/MUTING position, the STEREO indicator lights during an FM stereo broadcast reception. However, it does not light during an FM mono broadcast reception.

## ⑪ TUNING meter

This meter is used for precise tuning to the center of an FM channel. Turn the tuning knob until the meter pointer is in the center of the meter scale. This provides maximum separation and minimum distortion.

## ⑫ SIGNAL meter

This meter indicates signal strength for AM and FM. Maximum deflection indicates best receiving condition.

# CONNECTING INSTRUCTIONS

## SPEAKER CONNECTION

In connecting only one pair of speakers, connect the right speaker to **R** and the left speaker to **L** of the SPEAKERS A terminals. Should (+) or (-) of either right or left channel be reversely connected, sounds at the center section will be adversely affected by the lack of separation. To connect an additional pair of speakers, connect the right speaker to **R** and the left speaker to **L** of the SPEAKERS B terminals.

Sound cannot be heard when the SPEAKERS switch on the front panel is set to the A+B position and only one pair of speakers (connected to either SPEAKERS A terminals or B ones) are used. This is because A and B speaker circuits are in series and is not an indication of any trouble.

When connecting the speaker leads to the speaker terminals, make sure that the bare wires at the tips of the speaker leads do not touch the adjacent terminal.

It is recommended that the wires of individual speaker lead tips are soldered or they are stranded together to eliminate any possibility of short-circuits forming in the speaker connecting network.

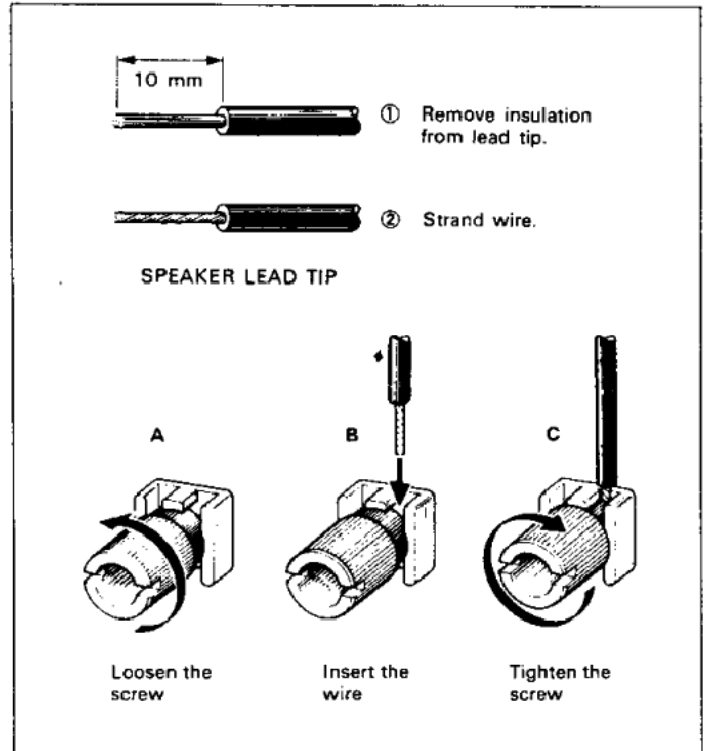

### NOTE:

The impedance of each speaker should be 4 ohms or more when only one pair of speakers are used or when two pairs of speakers are simultaneously used (A+B).

## PHASING OF THE SPEAKERS

Speaker phasing can be determined in the following manner:

1. Set the SELECTOR switch to FM (MONO).
2. Adjust the VOLUME control to the desired listening level.
3. If the sound comes directly from the front, the speakers are in phase. If the sound comes from both sides and there is a noticeable loss in low frequencies, the speakers are out of phase. In this case reverse the leads on one speaker.

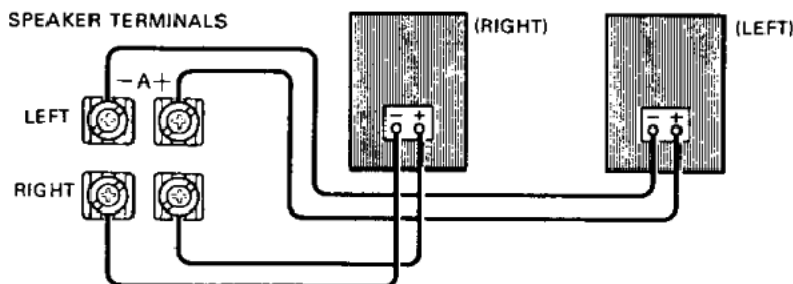

# CONNECTING INSTRUCTIONS

## TURNTABLE CONNECTION

The two shielded audio cables from your stereo turntable are normally terminated with phono plugs. Connect the left channel of the turntable to **L** of the INPUT PHONO jack and the right channel to **R** of the INPUT PHONO jack.

If the turntable has a grounding wire, connect it to this unit's GND terminal to avoid hum.

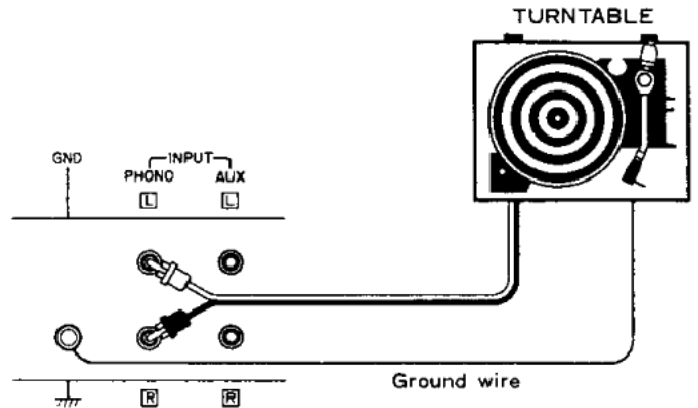

## TAPE DECK CONNECTION

### Recording

A tape deck can be connected for recording as follows: the left channel input of the tape deck to **L** of the TAPE REC jack, the right channel input of the tape deck to **R** of the TAPE REC jack.

### Playback

A tape deck can be connected for playback as follows: the left channel output of the tape deck to **L** of the TAPE PLAY jack, the right channel output of the tape deck to **R** of the TAPE PLAY jack.

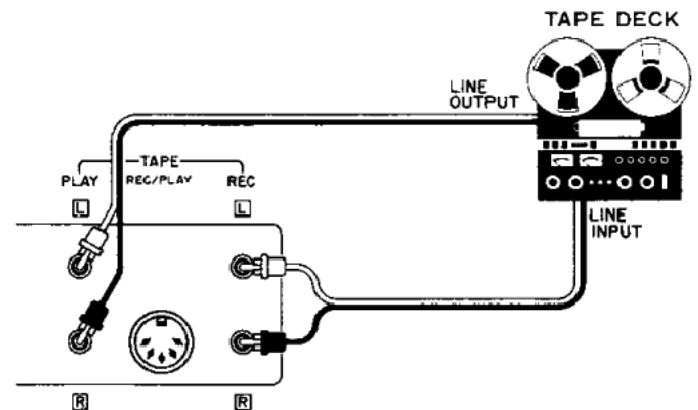

## DIN CONNECTOR (REC/PLAY CONNECTOR)

If your tape deck is equipped with a DIN connector, connect it to the TAPE REC/PLAY connector with a DIN connecting cord. A DIN connector enables recording and playback with this single cord.

### NOTES:

- 1) Please note that the REC/PLAY connector corresponds to the TAPE REC and PLAY — the signal must be controlled with TAPE switch on the front panel.
- 2) When a DIN cord is used for connecting to the tape deck, the PLAY and REC jacks should not be used.

## AUX (AUXILIARY INPUTS)

High level AUX input jacks are for miscellaneous sources, such as extra tape decks, TV sound outputs, and other external components.

## AC OUTLETS

The AC outlets on the rear panel of the receiver may be used to supply power to other components, such as a turntable, tape deck, etc.

### 1. SWITCHED outlet

This outlet is controlled by the POWER switch on the front panel. (The capacity is 200 watts maximum.)

### 2. UNSWITCHED outlet

This outlet delivers power at all times. (The capacity is 200 watts maximum.)

### NOTES:

- 1) Units shipped to the European countries are not equipped with the AC OUTLETS.
- 2) Do not connect any equipment whose power consumption exceeds the capacity of each outlet.

# CONNECTING INSTRUCTIONS

## FM ANTENNA CONNECTIONS

Since FM broadcast signals travel along a straight and direct-line path, they become rather weak behind hills and buildings even in the vicinity of a transmitting station. FM signals also become weak in areas distant from a station even though there may not be any obstruction to the direct-line path of the signal. Therefore, a good FM antenna should be installed in the most effective manner for the best possible FM reception.

### FM Outdoor Antenna

In areas at a greater distance from the transmitting station, the use of an outdoor antenna is highly recommended. It is available in various types. For reception of stations located in many directions, a non-directional type antenna will offer better results. When using a directional antenna, always orient it for the best reception of the desired station. The correct position will be indicated by maximum deflection of the SIGNAL meter on the unit.

Connections should be made as indicated by figures. Keep FM antennas away from roads to avoid noises made by the ignition of car, motorcycle, etc.

#### NOTE:

Consult audio dealer for detailed information of FM outdoor antenna installation.

### T-type Antenna

In areas close to the transmitting station, a simple T-type antenna may suffice. It should be remembered, however, that the pickup of reflections (similar to "ghosts" on TV) will result in poor stereo reception.

These reflections must therefore be reduced to a minimum, either by careful orientation of the indoor T-type antenna or, if this will not eliminate them, by using a more directional outdoor type antenna.

Spread the 2 arms of the antenna horizontally and while listening to an FM station, position them for the best reception. The antenna can then be taped to a wall or ceiling.

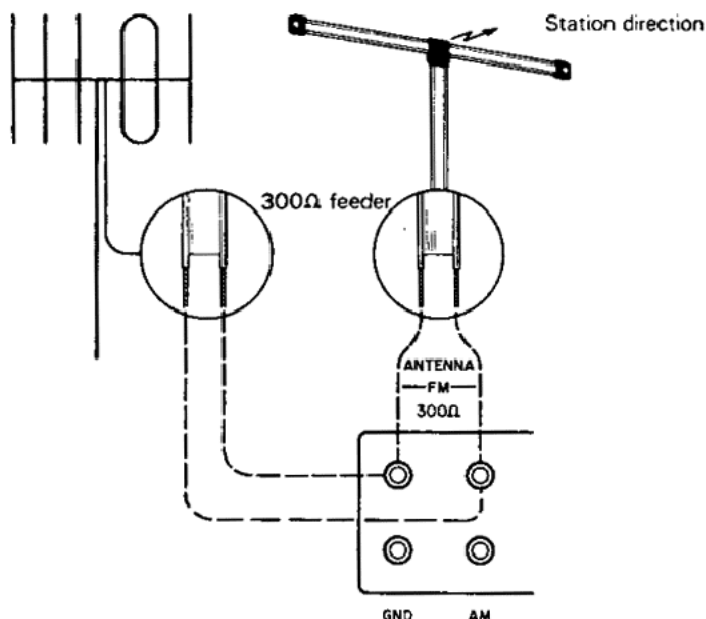
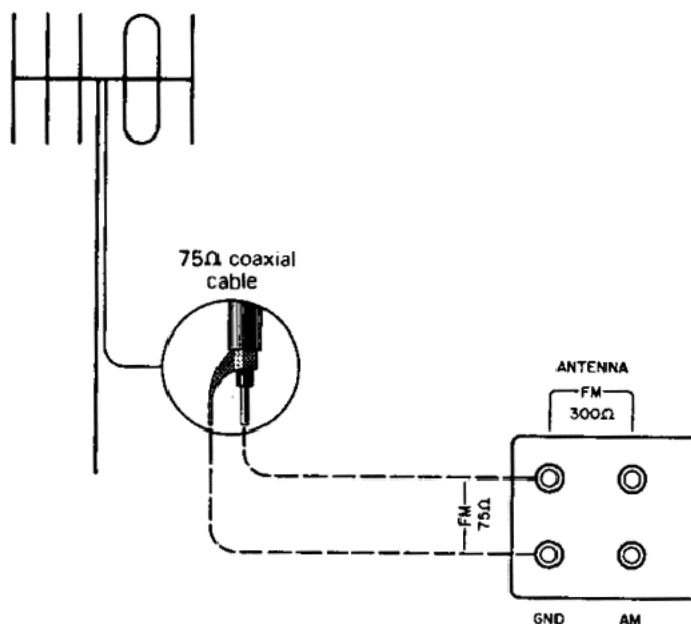



# CONNECTING INSTRUCTIONS

## AM ANTENNA CONNECTION

Normally, position the ferrite bar antenna for best reception while listening to an AM station as described on page 10.

### AM Indoor Antenna

The ferrite bar antenna employed on the rear panel assures optimum AM reception.

### AM Outdoor Antenna

In fringe areas or in locations surrounded by steel frame buildings where satisfactory reception cannot be obtained with the ferrite bar antenna, an AM outdoor antenna should be connected to the AM terminal.

## GROUND

It is advisable to connect the GND terminal on the rear panel to the ground by using a buried grounding rod or iron-made water pipe to reduce the noise and ensure safety. However, never use a gas pipe for this purpose.

## DIN-TYPE ANTENNA JACKS

Units shipped to European countries are equipped with the DIN-type antenna jacks on the rear panel.

**NOTE:** Consult audio dealer for detailed information on making connections.

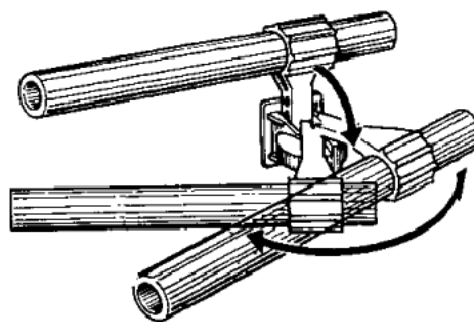

Keep the AM ferrite bar antenna away from the rear panel.

## AM ANTENNA SETTING

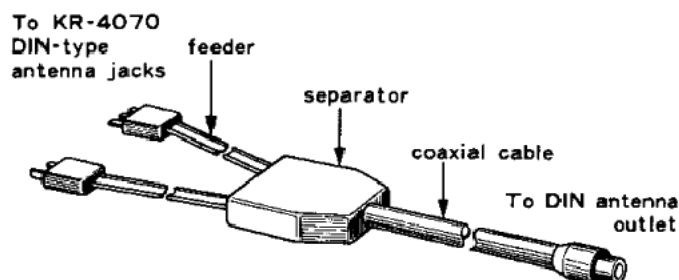
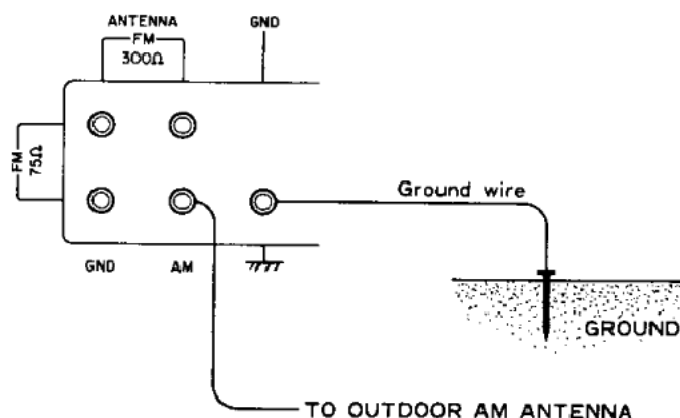

## DIN-TYPE ANTENNA CONNECTOR

## PRECAUTIONS FOR SAFETY

- Switch off the unit and disconnect the power plug from your AC outlet immediately if the abnormality (smell, smoke, etc.) should take place.
- When you connect or disconnect the power plug from your AC outlet, never do it with wet hands to avoid unexpected accident from electric shock. Besides, do it by holding the power plug itself.
- Disconnect the power plug from your AC outlet when it begins to thunder terrifically. Also, it is safe to disconnect the antenna feeder (or coaxial cable) from the unit if an outdoor antenna is installed. Do not touch the antenna feeder (or coaxial cable) disconnected then.
- It is desirable to disconnect the power plug from your AC outlet when you leave your house for a long time.

- \* \* \*
- The power cord must not be pulled strongly, nor bent forcibly, nor scratched, nor extended by connecting an extra cord. This will damage the cord and be a cause of electric shock and a fire.
  - Do not put a heavy thing on the power cord.
- \* \* \*
- Do not put on and near the unit what contains water (vase, etc.).
  - Do not put in the unit the inflammable (paper, celluloid, etc.) and the metal (needle, hairpin, coin, etc.).
- \* \* \*
- Never dismantle the case from the unit and touch the internal part. Never modify the internal part. Otherwise, the danger of electric shock will be incurred.

# OPERATING INSTRUCTIONS

Prior to turning on the unit, set each control and switch as below.

- TAPE —————→ "SOURCE"
- LOUDNESS —————→ "OFF"
- VOLUME —————→ "MIN"
- BALANCE —————→ Center Position
- TREBLE —————→ Center Position
- BASS —————→ Center Position

Next, turn on the unit and set the SPEAKERS switch to "PHONES", "A", "B" or "A + B" in accordance with the item to be operated.

## FM RECEPTION

1. Set the SELECTOR switch to FM AUTO MUTING.
2. Turn the TUNING knob to select your station. Best reception is obtained when the TUNING meter pointer is exactly in the center and the SIGNAL meter pointer deflects to the extreme right.

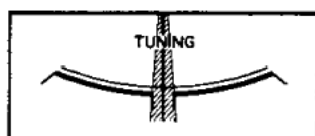
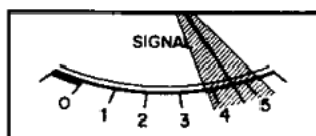

FM Reception

3. Adjust volume and tone quality.

### NOTE:

It may be impossible to eliminate noise from an FM stereo broadcast if the signal is extremely weak. In such a case the relative signal strength can be improved by setting the SELECTOR switch to FM MONO. While the stereo effect will be lost, a great deal of the noise can be substantially eliminated.

## AM RECEPTION

1. Set the SELECTOR switch to AM.
2. Turn the TUNING knob to select your station. Best reception is obtained when the SIGNAL meter pointer deflects to the extreme right.

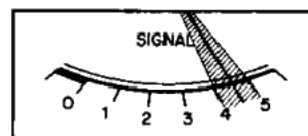

AM Reception

3. Adjust volume and tone quality.

## TURNTABLE OPERATION

1. Set the SELECTOR switch to PHONO.
2. Operate the turntable.
3. Adjust volume and tone quality.

## AUX JACKS UTILIZATION

To play component connected to the AUX jacks, proceed as follows:

1. Set the SELECTOR switch to AUX.
2. Operate the component connected.
3. Adjust volume and tone quality.

# OPERATING INSTRUCTIONS

## TAPE DECK OPERATION

### Playback

1. Set the TAPE switch to PLAY (depressed position). The SELECTOR switch can be in any position.
2. Operate the tape deck.
3. Adjust volume and tone quality.

### Monitoring

If you use the unit with 3-head type tape decks, you can check the sound quality of the recording by momentarily comparing the recorded signal with the source signal as follows.

- Set the TAPE switch to PLAY to monitor the recorded sound.
- Set the TAPE switch to SOURCE to monitor the source signal before recorded.

### Recording

1. Set the SELECTOR switch to the source to be recorded as shown in the figure (right middle).
2. Operate the selected source (component) and the tape deck.
3. Adjust recording levels with the tape deck's control.
4. To check recording conditions, set the TAPE switch to PLAY (depressed position).

### NOTE:

Recording is not affected by the unit's controls such as VOLUME, BASS, TREBLE, LOUDNESS and BALANCE.

### Tape-To-Tape Dubbing (Duplicating)

1. Connect two tape decks as shown in the figure (right bottom).
2. Set the SELECTOR switch to AUX and operate the tape deck connected to the AUX jacks as the program source.
3. Record the program onto the tape deck connected to the TAPE jacks, controlling the recording level with the controls on that deck.
4. To check recording conditions, set the TAPE switch to PLAY (depressed position).

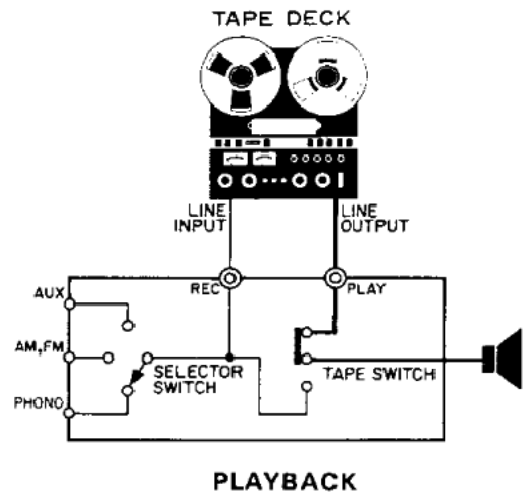

PLAYBACK

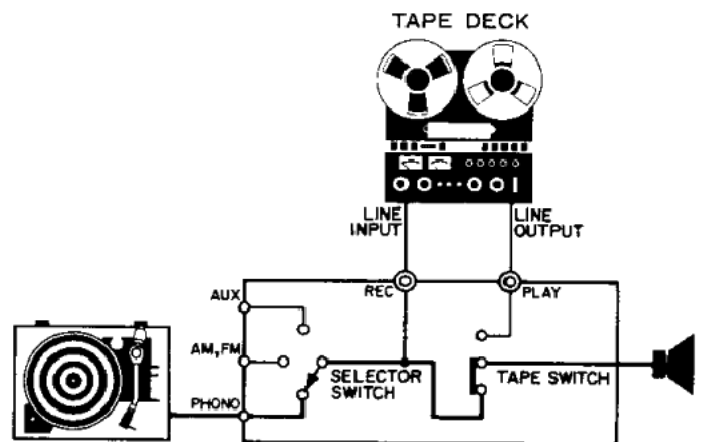

RECORDING

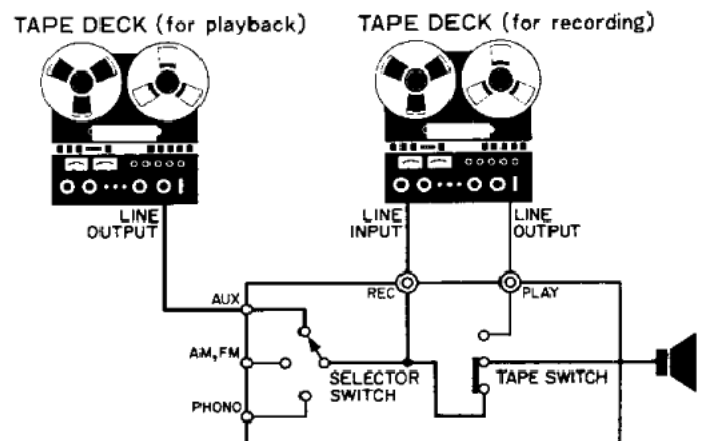

TAPE-TO-TAPE DUBBING

### PRECAUTIONS ON CLEANING

Do not use volatile liquid such as alcohol, thinner, gasoline, benzene, etc., when cleaning the unit surface. Use silicon cloth or soft dry cloth.

# POINTS TO BE CHECKED PRIOR TO SERVICING

Occurs Only During AM Reception	Correction
Continuous low frequency buzz. Most noticeable at night on weak signal stations. Continuous high frequency whine increases at night.	Erecting a 10-meter outdoor antenna and securing good ground conditions should reduce interference considerably. Complete elimination is difficult.  Turn TV off. (Neighboring TV set may also be cause.) Impossible to eliminate from receiver side.
Occurs Only During FM Reception	Correction
Continuous hiss or buzzing interference with broadcast. Becomes louder during stereo.	Erect outdoor FM antenna if only indoor T-type is used. An antenna with more than 5 elements is necessary if you are located at a considerable distance from the transmitting station.
During AM, FM or Turntable	Correction
No sound from LEFT and RIGHT.  Sound only from one side.	Check connections from receiver output to speakers. Set to appropriate volume level. Always set to SOURCE except when using tape decks. Check receiver output and speakers connections.
During Record Playback Only	Correction
No sound from LEFT and RIGHT, or sound only from one side.  Sound audible but background hum occurs.  Howling noise occurs when volume is raised or bass response is increased.	See that turntable output cord is firmly plugged into receiver input.  Keep turntable output cord away from AC cords. Choose cord paths which keep hum at a minimum. Twist LEFT-RIGHT turntable output cords together. Reverse turntable AC plug connections. Connect turntable groundwire to GND terminal.  Increase distance between turntable and speakers. Choose speaker locations carefully. Remember, loose flooring induces howling.

## SPECIFICATIONS

### AMPLIFIER SECTION

#### Power Output

**40 watts\* per channel, minimum RMS at 8 ohms, from 20 Hz to 20,000 Hz with no more than 0.1% total harmonic distortion**

<b>Both Channels Driven:</b>	40 + 40 watts 8 ohms at 1,000 Hz 47 + 47 watts 4 ohms at 1,000 Hz
<b>Dynamic Power Output:</b>	190 watts 4 ohms
<b>Total Harmonic Distortion:</b>	0.1% at rated power into 8 ohms 0.05% at 1 watt into 8 ohms
<b>Intermodulation Distortion:</b> (60 Hz : 7 kHz = 4 : 1)	0.1% at rated power into 8 ohms 0.05% at 1 watt into 8 ohms
<b>Power Bandwidth:</b>	10 Hz to 40,000 Hz
<b>Damping Factor:</b>	40 at 8 ohms
<b>Speaker Impedance:</b>	Accept 4 ohms to 16 ohms
<b>Input Sensitivity/Impedance/Signal to Noise Ratio (IHF A Curve):</b>	
Phono:	2.5 mV/50k ohms/73 dB
AUX:	150 mV/45k ohms/95 dB
Tape:	150 mV/45k ohms/95 dB
<b>Maximum Input Level for Phono:</b>	190 mV (rms), T.H.D. 0.1% at 1,000 Hz
<b>Output Level/Impedance:</b>	
Tape REC (Pin):	150 mV/100 ohms
(DIN):	30 mV/80k ohms
<b>Frequency Response:</b>	
Phono:	RIAA standard curve +0.3 dB, -0.3 dB
AUX and Tape:	15 Hz to 70,000 Hz +0 dB, -1.0 dB
<b>Tone Control:</b>	
Bass:	±8 dB at 100 Hz
Treble:	±8 dB at 10,000 Hz
<b>Loudness Control (-30 dB):</b>	+9 dB at 100 Hz +5 dB at 10,000 Hz

### FM TUNER SECTION (IHF)

<b>Usable Sensitivity:</b>	10.8 dBf (1.9 μV)
<b>50 dB Quieting Sensitivity:</b>	
(Mono):	15 dBf (3.1 μV)
(Stereo):	37.2 dBf (40 μV)

### Signal to Noise Ratio at 65 dBf:

(Mono):	72 dB
(Stereo):	67 dB
<b>T.H. Distortion at 65 dBf:</b>	
(Mono):	0.15%
(Stereo):	0.25%
<b>Frequency Response:</b>	20 to 15,000 Hz + 0.5 dB, -2.0 dB
<b>Capture Ratio:</b>	1.0 dB
<b>Alternate Channel Selectivity:</b>	60 dB
<b>Spurious Response Ratio:</b>	75 dB
<b>Image Response Ratio:</b>	45 dB
<b>IF Response Ratio (Balanced):</b>	95 dB
<b>AM Suppression Ratio:</b>	53 dB
<b>Stereo Separation:</b>	43 dB at 1,000 Hz 35 dB at 50 to 10,000 Hz
<b>Sub Carrier Product Ratio:</b>	40 dB
<b>Antenna Impedance:</b>	300 ohms balanced and 75 ohms unbalanced
<b>FM Frequency Range:</b>	88 MHz to 108 MHz

### AM TUNER SECTION

<b>Usable Sensitivity:</b>	16 μV
<b>Signal to Noise Ratio:</b>	50 dB
<b>Image Rejection:</b>	50 dB
<b>Selectivity:</b>	34 dB

### GENERAL

<b>Power Consumption:</b>	300 watts at full power
<b>A.C. Outlet:</b>	Switched 1, Unswitched 1
<b>Dimensions:</b>	W 18-7/16" (468 mm) H 5-7/8" (149 mm) D 14-3/16" (360 mm)
<b>Weight (Net):</b>	20.7 lb (9.4 kg)

### Note:

Kenwood follows a policy of continuous advancements in development. For this reason, specifications may be changed without notice.

\*Measured pursuant to Federal Trade Commission's Trade Regulation rule on Power Output Claims for Amplifier in U.S.A.