

harman kardon

**MODEL HK20
POWER AMPLIFIER**

INSTRUCTION MANUAL

It is essential you read this instruction booklet carefully before installing your high fidelity system. You have invested in an extremely fine electronic instrument into which many excellent engineering developments have been incorporated, and each is important for the proper operation of your system. This booklet has been written in simple non-technical language and if you will take time to read it first before doing anything else, you will find it simple to obtain optimum performance from your Harman-Kardon Amplifier.

Be sure to keep this booklet available at all times. It contains indispensable technical and service information.

UNPACKING

After unpacking the HK20, inspect it carefully for signs of transit damage. The unit was subjected to many inspections and tests prior to final packing, and it therefore should be in perfect condition. If damage is visible, notify your dealer at once. If the unit was shipped to you, notify the transportation company without delay.

Check the contents of the carton thoroughly and inspect the folds of the packing material before discarding it. Your package should contain the following items:

- 1 Model HK20 Basic Power Amplifier.
- 1 Instruction Booklet.
- 1 Warranty Card.

WARRANTY POLICY

We urge you to completely fill in your warranty card and mail it to the factory without delay to protect your rights under warranty. The warranty cards are carefully filed for reference and should you require information on the use of this high fidelity unit, or repair service, we will be able to immediately identify your set and reply quickly.

NOTE: It is necessary to receive factory authorization before returning a set for warranty repair either to the factory or to an authorized station. Repairs are to be returned on an Express Prepaid basis. A letter describing the exact difficulty must be enclosed with the unit.

WARRANTY

We warrant each Model HK20 to be free from defects in material and workmanship under normal use and service, and in accordance with the conditions herein below set forth, for a period of 1 year from date of delivery to the original purchaser, and agree to replace or repair any part or parts, with the exception of tubes which are under the manufacturer's 90 day warranty, returned to us within said 1 year, with transportation prepaid and which our examination shall disclose to our satisfaction to have been thus defective. This warranty does not include free labor, nor is it applicable to any instrument which shall have been repaired or altered in any way so as in our judgment to affect its stability or reliability nor which has been subject to neglect, misuse, abuse, negligence or accident nor which has had the serial number altered, effaced, or removed. Neither shall this warranty apply to any instrument which has been connected otherwise than in accordance with instructions furnished by us.

This warranty is expressly in lieu of all other warranties, express or implied, and of all other obligations or liability on our part, and we neither assume nor authorize any representative or other person to assume for us any other liability in connection with the sale of this instrument.

USING THE HK20 POWER AMPLIFIER

INSTALLATION PROCEDURE

Ventilation:

The unit is well ventilated in itself, but sufficient space must be allowed around it to permit proper air flow. Install the amplifier in a manner to allow for unrestricted circulation. Do not place books or other objects on the cage or in the immediate vicinity of the instrument. Reducing the air flow will result in sharply reduced component and tube life.

Power Requirements:

Plug the AC cord into any outlet furnishing 117 volts 50 or 60 cycle AC current. The voltage may vary between 105 and 125 volts.

REAR PANEL CONNECTIONS

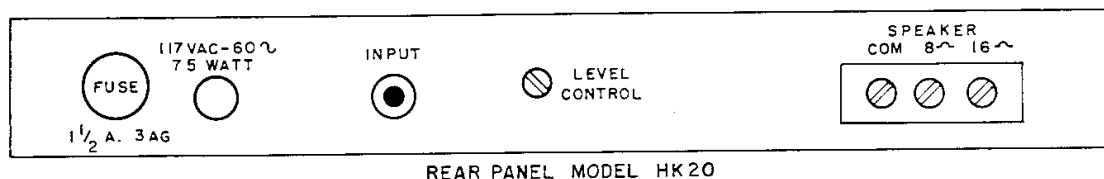

Connecting Your Speaker:

The SPEAKER OUTPUT terminal strip is located on the rear of the chassis. If you are using an 8 ohm speaker connect one speaker lead to the 8 ohm terminal and the other lead to COM. For a 16 ohm speaker connect one speaker lead to the 16 ohm terminal and the other lead to COM.

Input Connection:

To connect your HK20 to a monaural preamplifier attach the shielded cable supplied with the amplifier between the INPUT jack on the HK20 and the output jack on the preamplifier. If you are connecting the HK20 to the AX20 converter connect the shielded lead between the HK20 INPUT jack and the LEFT PREAMP OUT jack on the AX20.

Input Level Control:

This control adjusts the gain of the HK20 power amplifier. For monaural application it should be set to maximum. For stereo use it is set to balance your other amplifier. When used in conjunction with the Harman-Kardon AX20, the INPUT LEVEL control should be used in the following manner.

1. Turn the INPUT LEVEL control on the HK20 to zero.
2. Turn the volume control on your AX20 to normal listening level, and set the balance control to the mid-position.
3. Play a stereo record or tape. The left channel should be completely inoperative since the INPUT LEVEL control on the HK20 is set at zero.
4. Slowly rotate the HK20 INPUT LEVEL control until the left channel perfectly balances the right.
5. Allow the INPUT LEVEL control to remain set in this position. Further adjustment should not be necessary. All additional channel balancing should be made with the balance control on the AX20 converter.

ADJUSTMENTS

Hum Adjust Control:

This control is accessible from the underside of the chassis with the bottom plate removed and from the top of the unit with the cage removed. It is physically located between the EZ81 rectifier tube and the 6CG7.

To adjust, allow the amplifier to thoroughly warm up. Disconnect the input from the preamplifier stage and turn the INPUT LEVEL control to maximum. While listening to the hum level in your speaker, turn the HUM ADJUST control for minimum hum.

Output Tube Balance Control:

The BALANCE control is accessible from the underside of the chassis with the bottom plate removed and from the top of the unit with the cage removed. It is physically located between the EL84 output tubes. This control is preset at the factory and should not be touched unless the output tubes are changed or a periodic yearly check is required. When adjustment is necessary follow the outlined procedure.

1. Turn the INPUT LEVEL control on the HK20 to minimum.
2. Remove the shielded connecting cable from the INPUT jack.
3. Slowly rotate the OUTPUT TUBE BALANCE control for minimum hum in your speaker.
4. If the hum level is inaudible, set the OUTPUT TUBE BALANCE control to the exact center position.
5. For those who demand supercritical adjustment of this control, the adjustment should be made with an IM analyzer.

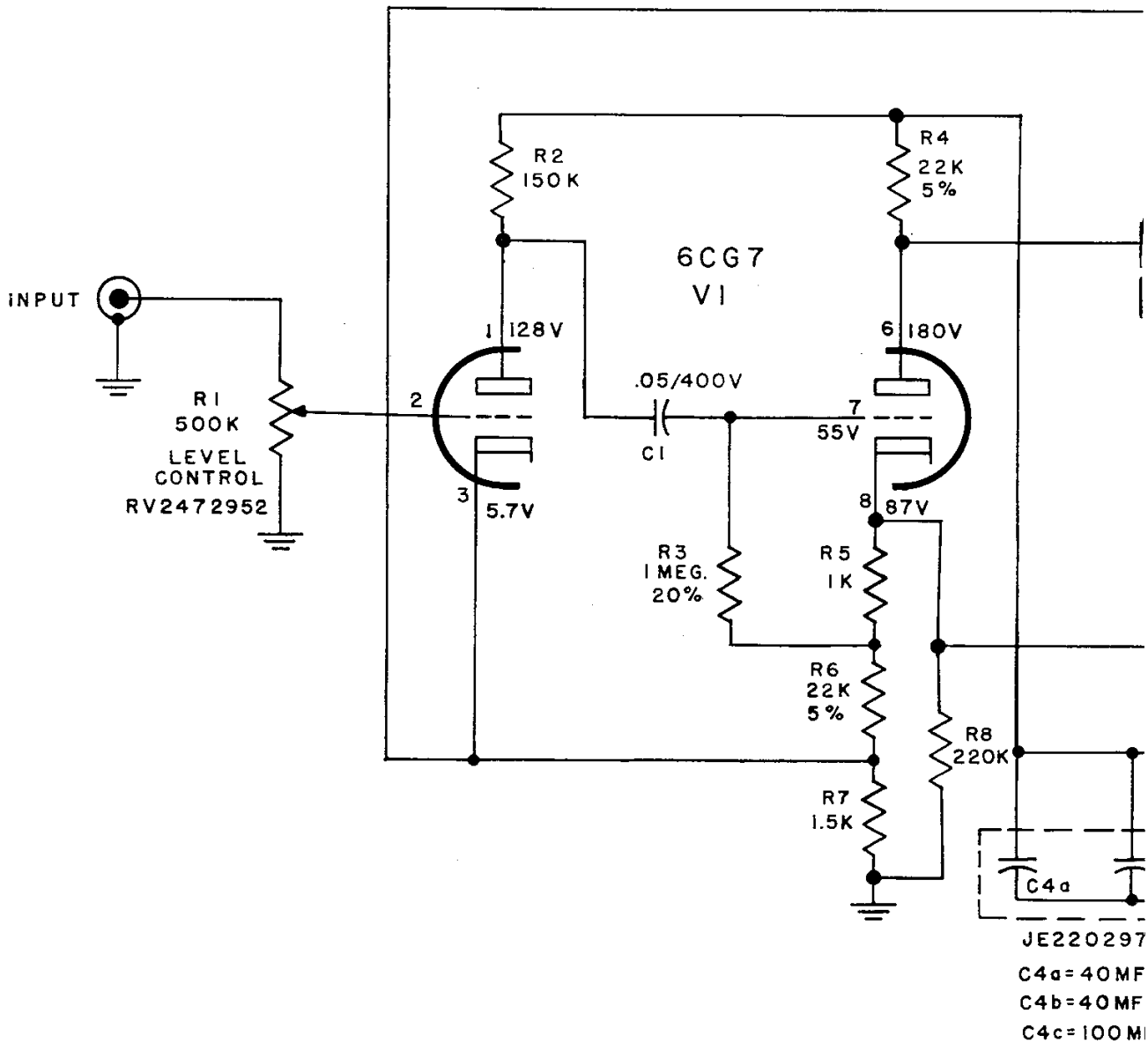

* RESISTANCE CHART

TUBE	1	2	3	4	5	6	7	8	9
V1 6CG7	>10M	0	1.5K	150	150	>1M	1M	24K	
V2 EL84		470K	150	150	150		>500K		>1M
V3 EL84		470K	150	150	150		>500K		>1M
V4 E281	85		>1M	150	150		85		

* LEVEL CONTROL MIN. GAIN

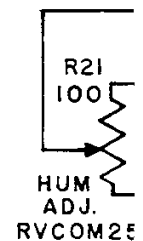

NOTE:

UNLESS OTHERWISE SHOWN
 ALL RESISTORS 1/2 WATT ± 10%
 ALL CAPACITOR VALUES WITH DECIMAL TO BE PAPER IN MFD
 ALL CAPACITOR VALUES WITHOUT DECIMAL TO BE GENERAL
 PURPOSE CERAMICS 500WVDC IN MMF
 ALL VOLTAGES ARE DC
 ALL RESISTANCES ARE IN OHMS

S 247
 S 2473018A

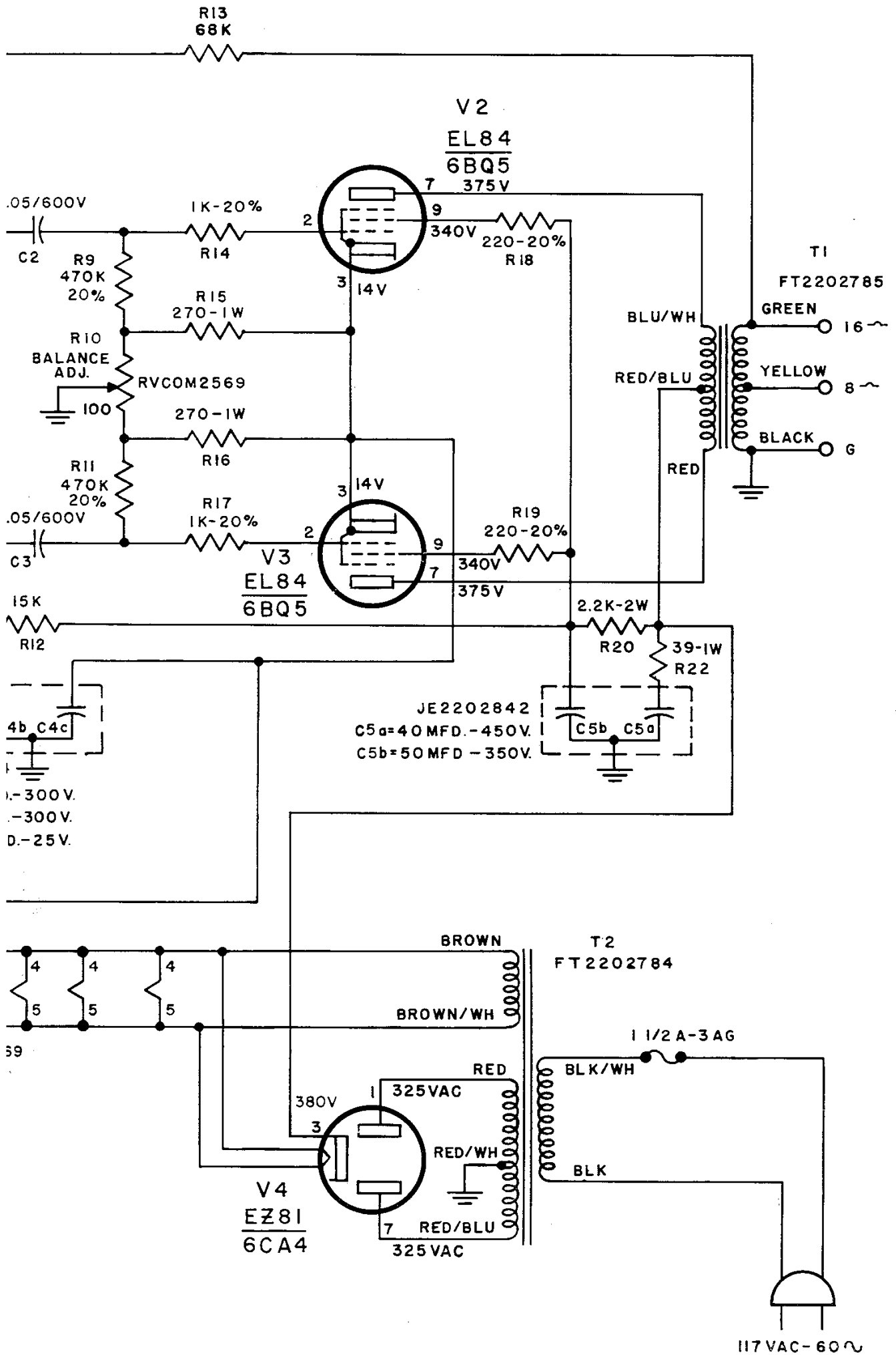

SPECIFICATIONS

Audio

Circuits:	2 - EL84's self biased, pentode connected in push-pull.
Output Level:	20 watts at less than 1% harmonic distortion. 17 watts at less than 0.5% harmonic distortion. 5 watts at less than 0.2% harmonic distortion. 17 watts at less than 2% intermodulation distortion. Harmonic distortion readings at 1000 c.p.s.; Inter- modulation distortion readings at 60/6000 c.p.s.; 4:1; All at 16 ohm load—120 volts
Peak Power Output:	40 watts.
Output Impedance:	8 and 16 ohms.
Frequency Response:	± 0.5 db 15-30,000 c.p.s. at 1 watt. ± 1.0 db 20-20,000 c.p.s. at 15 watts.
Damping Factor:	5
Hum:	90 db below 20 watts.
Sensitivity:	0.5 volts
Fuse:	Externally accessible
Tube Complement:	(Total 4) 1-EZ81, 2-EL84, 1-6CG7
Dimensions:	10" w. x 5" h. x 4" d.
Power Consumption:	60 watts
Shipping Weight:	14 lbs.

MAINTENANCE AND REPAIRS

Fuse:

In the event of a potentially damaging failure of tubes or components, the Model HK20 is protected by a 1½ ampere, type 3AG fuse, located on the rear of the unit. If this fuse is blown, it should be replaced only with one of the same rating. Replacing with a fuse of higher rating will not protect the amplifier, and may result in severe damage, which will not be covered by the factory warranty.

Routine Maintenance:

Due to the conservative design and high quality components of the Model HK20, no routine maintenance other than yearly tube checking is advised. Occasional resetting of the hum and output balance adjustments, following the procedure described above, will keep the unit operating at peak efficiency. These adjustments should certainly be made after any tube replacement.

Repair:

Only the most qualified service technician should be employed, as special equipment and training is required to properly service a high fidelity amplifier. This manual contains information of great value to the repairman, and should be kept available.

Factory Warranty Stations are maintained in most major cities. For the address of the nearest one, or for any other information relating to your Harman-Kardon products, write to the attention of the Customer Service Department, Harman-Kardon, Inc., 520 Main St., Westbury, N.Y. Be sure to include the model and serial number of the set in question. A short description of your complete installation is often of help in answering your questions.

LIST OF REPLACEABLE PARTS

Part No.	Description	List Price
ZCOM2953	Fuse	.10
RVCOM2569	Balance Control	.60
RV2472952	Level Control	.90
JE2202842	Electrolytic	3.00
JE2202974	Electrolytic	3.00
FT2202784	Power Transformer	14.75
FT2202785	Output Transformer	15.00